

THIS COPY IS PROVIDED ON A RESTRICTED BASIS AND IS NOT TO BE USED IN ANY WAY DETRIMENTAL TO THE INTERESTS OF PANDUIT CORP.

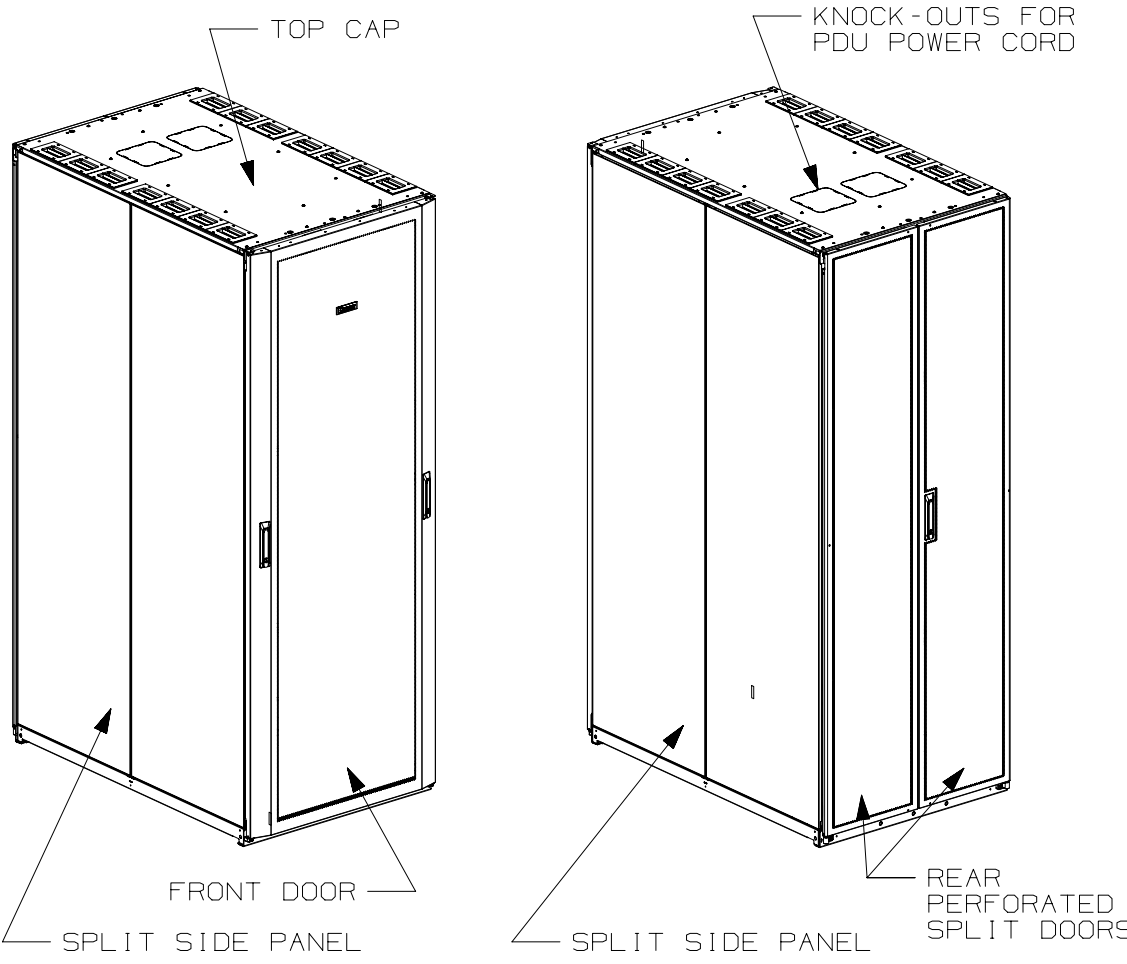

1. VISIT OUR ON-LINE CATALOG AT WWW.PANDUIT.COM FOR A LIST OF CURRENT PARTS APPLICABLE FOR USE WITH THIS PRODUCT.
2. PRIMARY DIMENSIONS ARE IN MILLIMETERS.
3. INDEPENDENT ADJUSTABLE REAR EQUIPMENT MOUNTING RAILS (EIA) ADJUST FROM 130mm [5.1in] TO 422mm [16.6in], AND FROM 469mm [18.46in] TO 751mm [29.56in]. WITH NO FINGERS OR PDU'S, 913mm [35.94in] TO 964mm [37.95in].
4. CAN BE USED WITH ANY 19" EIA STANDARD COMPONENT IN ADDITION TO ALL PANDUIT HORIZONTAL CABLE MANAGEMENT AND PATCH PANEL PRODUCTS.
5. EIA UNIVERSAL STANDARD HOLE PROGRESSION ON EQUIPMENT RAILS 15.88mm [.625in], 15.88mm [.625in], 12.70mm [.5in], 15.88mm [.625in], 15.88mm [.625in], 12.7mm [.5in]...ETC.
6. PARTS SUPPLIED:
 -BASE CABINET
 OPTIONAL COMPONENTS:
 -FRONT DOOR (SEE CHART ON SHEETS 2,3&4)
 -REAR PERFORATED SPLIT DOOR (SEE CHART ON SHEETS 2,3&4)
 -EQUIPMENT RAILS FRONT & REAR (SEE CHART ON SHEETS 2,3&4)
 -SPLIT SIDE PANELS (SEE CHART ON SHEETS 2,3&4)
 -VERTICAL CABLE MANAGEMENT FINGERS (SEE CHART ON SHEETS 2,3&4)
 -CABINET HARDWARE KIT
 -INSTRUCTION SHEET
7. RACK UNIT SPACING NUMERALS ARE CLEARLY PRINTED ON EQUIPMENT MOUNTING RAILS.
8. FULLY BONDED STRUCTURE WHEN ASSEMBLED PER INSTRUCTIONS.
9. STATIC LOAD RATING: 1360 Kg (3000 LBS)
10. ROLLING LOAD RATING: 1133 Kg (2500 LBS)
11. SINGLE POINT GROUND LOCATIONS AT TOP AND BOTTOM OF CABINET.
12. ALL CABINET RAILS ARE INSTALLED NUMBERS UP.
13. MAXIMUM EQUIPMENT DEPTH, 992mm [39.06].

REV	DATE	BY	CHK	APR	DESCRIPTION	ECN
02A	08-25-20	RAMA	ELE	ELE	REMOVED PART NUMBERS ENDING WITH S, J, AND M	V09000BX
01B	02-10-16	SSP	DDW	TCN	A. CORRECTED CABLE OPENING QUANTITY, WAS (12)	V09000TW
01A	12-11-14	PBS	ADP	TCN	FLOOR MOUNT DIMENSIONS UPDATED	V09000BX
00C	12-17-13	PBS	ROJC	JDWE	REVISED CHART	12V305LV-DC
00B	5-20-13	PBS	NAGL	JDWE	REVISED CHART	12V305LV-DC
00A	8-13-12	TWV	JDW	JDWE	RELEASED TO PRODUCTION	12V305LV-DC

TITLE				NET-ACCESS N TYPE CABINET 800mm WIDE X 1200mm DEEP FAMILY			
				CUSTOMER DRAWING			
ITEM REVISION NAME				12V305LV/02.PRT			
DATASET FILE NAME				12V305LV_DC_02A.PRT			
				MATERIAL: N/A			
				DRAWING NUMBER: 12V305LV-DC			
DRAWN BY		DATE		CHK		SCALE	
TWV		8-13-12		JDW		NONE	
THIRD ANGLE PROJECTION				SHT 1 OF 6			
				SIZE A			

THIS COPY IS PROVIDED ON A RESTRICTED BASIS AND IS NOT TO BE USED IN ANY WAY DETRIMENTAL TO THE INTERESTS OF PANDUIT CORP.

PART NO.	DESCRIPTION	DUAL HINGE DOOR	SPLIT DOOR	SINGLE HINGE DOOR	SPLIT SIDE PANEL	CAGE NUT E-RAIL (2-SETS)	TAPPED E-RAIL (2-SETS)	VERTICAL BLANKING PANELS	CABLE MANAGEMENT	CABINET WEIGHT FULLY UNPACKAGED	CABINET WEIGHT SHIPPING WEIGHT
N8222*	NET-ACCESS N-TYPE CABINET 42RUX1200mm DEEP	01	01	00	02	00	01	00	02	140 Kg/EACH 310 LBS/EACH	161 Kg/EACH 355 LBS/EACH
N8522*	NET-ACCESS N-TYPE CABINET 45RUX1200mm DEEP	01	01	00	02	00	01	00	02	150 Kg/EACH 332 LBS/EACH	171 Kg/EACH 377 LBS/EACH
N8822*	NET-ACCESS N-TYPE CABINET 48RUX1200mm DEEP	01	01	00	02	00	01	00	02	160 Kg/EACH 354 LBS/EACH	181 Kg/EACH 399 LBS/EACH
N8229*	NET-ACCESS N-TYPE CABINET 42RUX1200mm DEEP	01	01	00	00	00	01	00	02	104 Kg/EACH 230 LBS/EACH	125 Kg/EACH 275 LBS/EACH
N8529*	NET-ACCESS N-TYPE CABINET 45RUX1200mm DEEP	01	01	00	00	00	01	00	02	111 Kg/EACH 245 LBS/EACH	131 Kg/EACH 290 LBS/EACH
N8829*	NET-ACCESS N-TYPE CABINET 48RUX1200mm DEEP	01	01	00	00	00	01	00	02	118 Kg/EACH 260 LBS/EACH	138 Kg/EACH 305 LBS/EACH
N8229*C	NET-ACCESS N-TYPE CABINET 42RUX1200mm DEEP	01	01	00	00	01	00	00	02	100 Kg/EACH 220 LBS/EACH	120 Kg/EACH 265 LBS/EACH
N8529*C	NET-ACCESS N-TYPE CABINET 45RUX1200mm DEEP	01	01	00	00	01	00	00	02	106 Kg/EACH 235 LBS/EACH	127 Kg/EACH 280 LBS/EACH
N8829*C	NET-ACCESS N-TYPE CABINET 48RUX1200mm DEEP	01	01	00	00	01	00	00	02	113 Kg/EACH 250 LBS/EACH	134 Kg/EACH 295 LBS/EACH
N8222*C	NET-ACCESS N-TYPE CABINET 42RUX1200mm DEEP	01	01	00	02	01	00	00	02	148 Kg/EACH 326 LBS/EACH	168 Kg/EACH 371 LBS/EACH
N8522*C	NET-ACCESS N-TYPE CABINET 45RUX1200mm DEEP	01	01	00	02	01	00	00	02	157 Kg/EACH 346 LBS/EACH	177 Kg/EACH 391 LBS/EACH
N8822*C	NET-ACCESS N-TYPE CABINET 48RUX1200mm DEEP	01	01	00	02	01	00	00	02	166 Kg/EACH 366 LBS/EACH	186 Kg/EACH 411 LBS/EACH
N8222*E	NET-ACCESS N-TYPE CABINET 42RUX1200mm DEEP	00	01	01	02	01	00	00	02	148 Kg/EACH 326 LBS/EACH	168 Kg/EACH 371 LBS/EACH
N8522*E	NET-ACCESS N-TYPE CABINET 45RUX1200mm DEEP	00	01	01	02	01	00	00	02	157 Kg/EACH 346 LBS/EACH	177 Kg/EACH 391 LBS/EACH
N8822*E	NET-ACCESS N-TYPE CABINET 48RUX1200mm DEEP	00	01	01	02	01	00	00	02	166 Kg/EACH 366 LBS/EACH	186 Kg/EACH 411 LBS/EACH
N8229*E	NET-ACCESS N-TYPE CABINET 42RUX1200mm DEEP	00	01	01	00	01	00	00	02	111 Kg/EACH 246 LBS/EACH	132 Kg/EACH 291 LBS/EACH
N8529*E	NET-ACCESS N-TYPE CABINET 45RUX1200mm DEEP	00	01	01	00	01	00	00	02	117 Kg/EACH 259 LBS/EACH	138 Kg/EACH 304 LBS/EACH

* DENOTES COLOR
 B = BLACK
 W = WHITE

REV	DATE	BY	CHK	APR	DESCRIPTION	ECN
02A	08-25-20	RAMA	ELE	ELE	SEE SHEET 1 OF 7 FOR REVISIONS	V09000BX
01B	02-10-16	SSP	DDW	TCN	SEE SHEET 1 OF 7 FOR REVISIONS	V09000TW
01A	12-11-14	PBS	ADP	TCN	SEE SHEET 1 OF 7 FOR REVISIONS	V09000BX
00C	12-17-13	PBS	ROJC	JDWE	SEE SHEET 1 OF 7 FOR REVISIONS	12V305LV-DC
00B	5-20-13	PBS	NAGL	JDWE	SEE SHEET 1 OF 6 FOR REVISIONS	12V305LV-DC
00A	8-13-12	TWV	JDW	JDWE	SEE SHEET 1 OF 5 FOR REVISIONS	12V305LV-DC

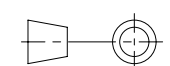
TITLE				NET-ACCESS N TYPE CABINET 800mm WIDE X 1200mm DEEP FAMILY			
CUSTOMER DRAWING							
ITEM REVISION NAME				12V305LV/02.PRT			
DATASET FILE NAME				12V305LV_DC_02A.PRT			
MATERIAL:				N/A			
DRAWING NUMBER:				12V305LV-DC			
DRAWN BY		DATE		CHK		SCALE	
T WV		8-13-12		JDW		NONE	
THIRD ANGLE PROJECTION							
SHT 2 OF 6				A			

THIS COPY IS PROVIDED ON A RESTRICTED BASIS AND IS NOT TO BE USED IN ANY WAY DETRIMENTAL TO THE INTERESTS OF PANDUIT CORP.

PART NO.	DESCRIPTION	DUAL HINGE DOOR	SPLIT DOOR	SINGLE HINGE DOOR	SPLIT SIDE PANEL	CAGE NUT E-RAIL (2-SETS)	TAPPED E-RAIL (2-SETS)	VERTICAL BLANKING PANELS	CABLE MANAGEMENT	CABINET WEIGHT FULLY UNPACKAGED	CABINET WEIGHT SHIPPING WEIGHT
N8829*E	NET-ACCESS N-TYPE CABINET 48RUX1200mm DEEP	00	01	01	00	01	00	00	02	123 Kg/EACH 272 LBS/EACH	144 Kg/EACH 317 LBS/EACH
N8222*U	NET-ACCESS N-TYPE CABINET 42RUX1200mm DEEP	01	01	00	02	01	00	01	02	140 Kg/EACH 310 LBS/EACH	161 Kg/EACH 355 LBS/EACH
N8522*U	NET-ACCESS N-TYPE CABINET 45RUX1200mm DEEP	01	01	00	02	01	00	01	02	150 Kg/EACH 332 LBS/EACH	171 Kg/EACH 377 LBS/EACH
N8822*U	NET-ACCESS N-TYPE CABINET 48RUX1200mm DEEP	01	01	00	02	01	00	01	02	160 Kg/EACH 354 LBS/EACH	181 Kg/EACH 399 LBS/EACH
N8229*U	NET-ACCESS N-TYPE CABINET 42RUX1200mm DEEP	01	01	00	00	01	00	01	02	104 Kg/EACH 230 LBS/EACH	125 Kg/EACH 275 LBS/EACH
N8529*U	NET-ACCESS N-TYPE CABINET 45RUX1200mm DEEP	01	01	00	00	01	00	01	02	111 Kg/EACH 245 LBS/EACH	131 Kg/EACH 290 LBS/EACH
N8829*U	NET-ACCESS N-TYPE CABINET 48RUX1200mm DEEP	01	01	00	00	01	00	01	02	118 Kg/EACH 260 LBS/EACH	138 Kg/EACH 305 LBS/EACH

* DENOTES COLOR
 B = BLACK
 W = WHITE

REV	DATE	BY	CHK	APR	DESCRIPTION	ECN	TITLE				MATERIAL:	
							NET-ACCESS N TYPE CABINET 800mm WIDE X 1200mm DEEP FAMILY				N/A	
							CUSTOMER DRAWING				DRAWING NUMBER:	
02A	08-25-20	RAMA	ELE	ELE	SEE SHEET 1 OF 7 FOR REVISIONS	V09000BX	ITEM REVISION NAME				12V305LV-DC	
01B	02-10-16	SSP	DDW	TCN	SEE SHEET 1 OF 7 FOR REVISIONS	V09000TW	DATASET FILE NAME				12V305LV_DC_02A.PRT	
01A	12-11-14	PBS	ADP	TCN	SEE SHEET 1 OF 7 FOR REVISIONS	V09000BX	THIRD ANGLE PROJECTION				12V305LV-DC	
00C	12-17-13	PBS	ROJC	JDWE	SEE SHEET 1 OF 7 FOR REVISIONS	12V305LV-DC	DRAWN BY				TWW	
00B	5-20-13	PBS	NAGL	JDWE	SEE SHEET 1 OF 6 FOR REVISIONS	12V305LV-DC	DATE				8-13-12	
00A	8-13-12	TWV	JDW	JDWE	SEE SHEET 1 OF 5 FOR REVISIONS	12V305LV-DC	CHK				JDW	
							SCALE				NONE	
							SHT 3 OF 6				A	

THIS COPY IS PROVIDED ON A RESTRICTED BASIS AND IS NOT TO BE USED IN ANY WAY DETRIMENTAL TO THE INTERESTS OF PANDUIT CORP.

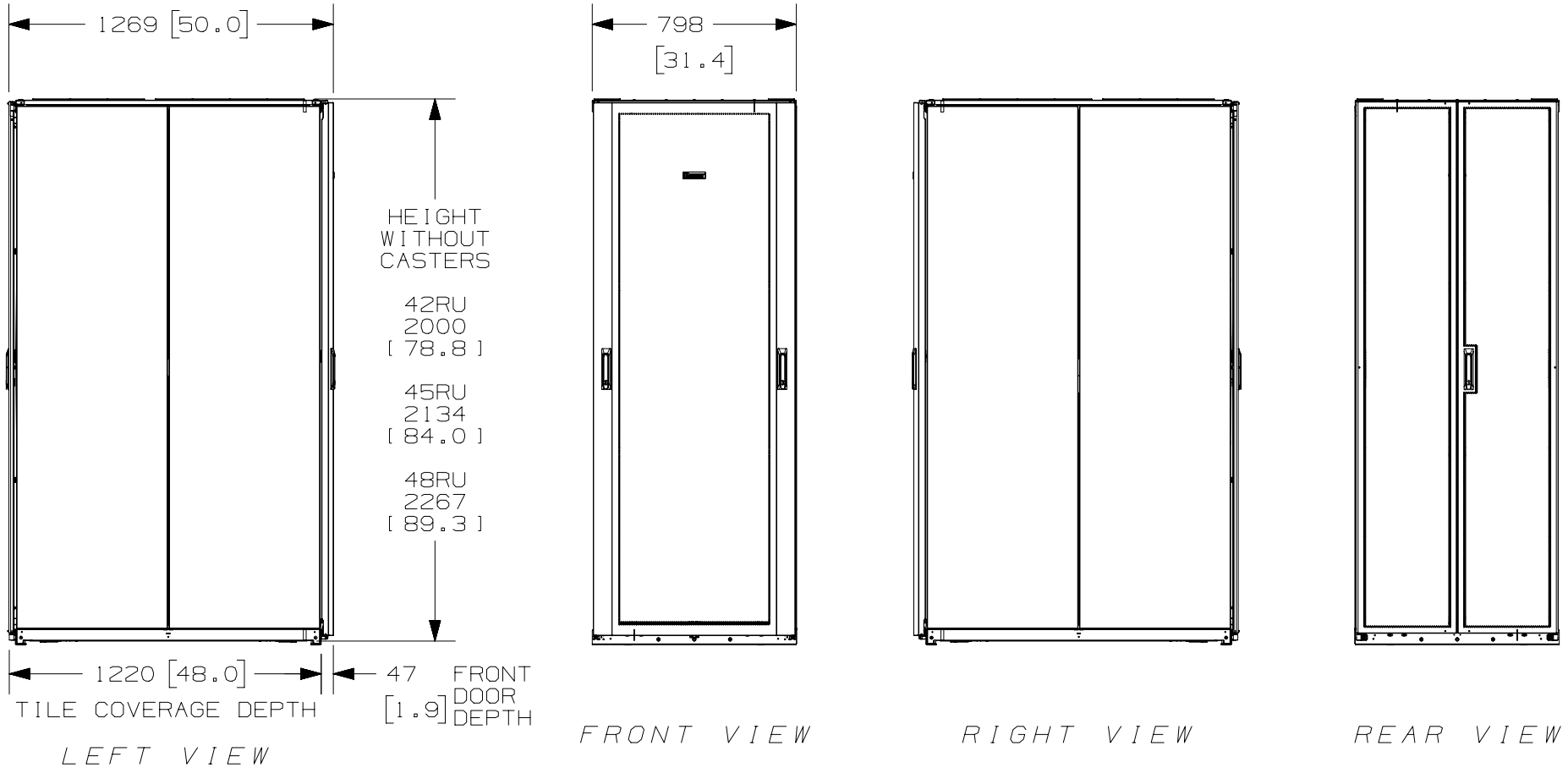

REV	DATE	BY	CHK	APR	DESCRIPTION	ECN
02A	08-25-20	RAMA	ELE	ELE	SEE SHEET 1 OF 7 FOR REVISIONS	V09000BX
01B	02-10-16	SSP	DDW	TCN	SEE SHEET 1 OF 7 FOR REVISIONS	V09000TW
01A	12-11-14	PBS	ADP	TCN	SEE SHEET 1 OF 7 FOR REVISIONS	V09000BX
00C	12-17-13	PBS	ROJC	JDWE	SEE SHEET 1 OF 7 FOR REVISIONS	12V305LV-DC
00B	5-20-13	PBS	NAGL	JDWE	SEE SHEET 1 OF 6 FOR REVISIONS	12V305LV-DC
00A	8-13-12	TWV	JDW	JDWE	SEE SHEET 1 OF 5 FOR REVISIONS	12V305LV-DC

TITLE				NET-ACCESS N TYPE CABINET 800mm WIDE X 1200mm DEEP FAMILY			
CUSTOMER DRAWING				DRAWING NUMBER: 12V305LV-DC			
ITEM REVISION NAME				12V305LV/02.PRT			
DATASET FILE NAME				12V305LV_DC_02A.PRT			
MATERIAL:				N/A			
THIRD ANGLE PROJECTION				DRAWING NUMBER: 12V305LV-DC			
DRAWN BY	DATE	CHK	SCALE	SHT 4 OF 6			
TWV	8-13-12	JDW	NONE	A			

THIS COPY IS PROVIDED ON A RESTRICTED BASIS AND IS NOT TO BE USED IN ANY WAY DETRIMENTAL TO THE INTERESTS OF PANDUIT CORP.

2

1

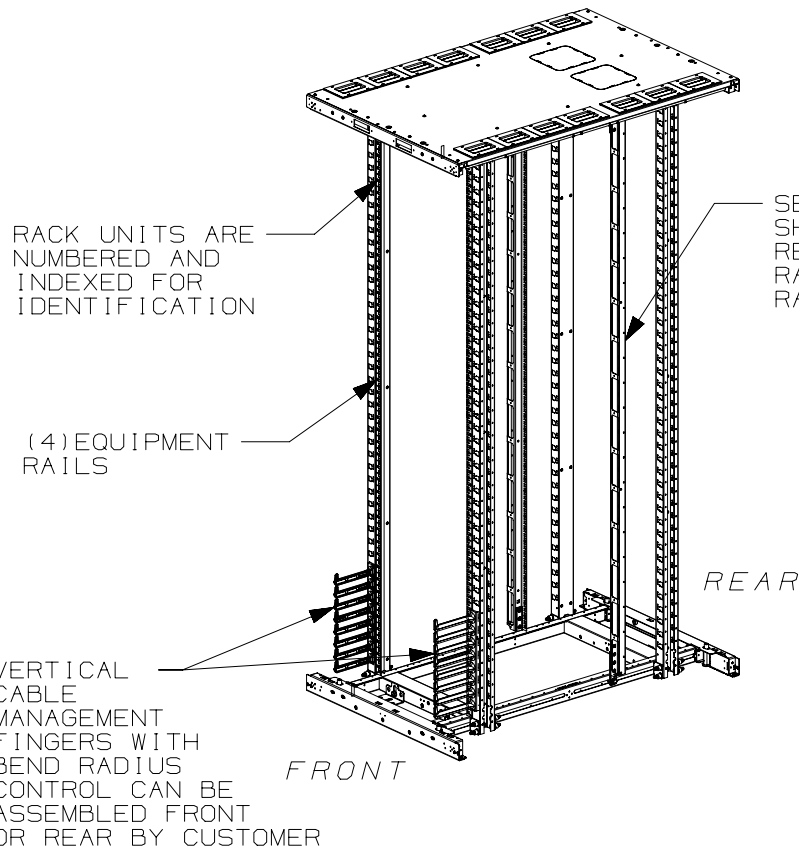

(6) LOCATIONS TAPPED FOR M10 THREADED ROD

SEE NOTES ON SHEET 1 FOR REAR EQUIPMENT RAIL ADJUSTMENT RANGE

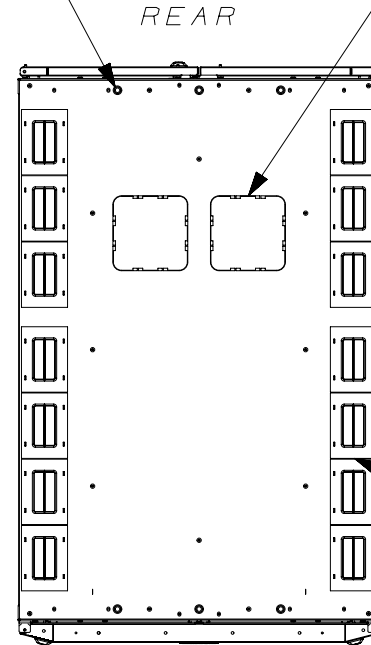

FRONT
TOP VIEW

FRONT DOOR, REAR DOOR,
AND SIDE PANELS NOT SHOWN

REV	DATE	BY	CHK	APR	DESCRIPTION	ECN
02A	08-25-20	RAMA	ELE	ELE	SEE SHEET 1 OF 7 FOR REVISIONS	V09000BX
01B	02-10-16	SSP	DDW	TCN	SEE SHEET 1 OF 7 FOR REVISIONS	V09000TW
01A	12-11-14	PBS	ADP	TCN	SEE SHEET 1 OF 7 FOR REVISIONS	V09000BX
00C	12-17-13	PBS	ROJC	JDWE	SEE SHEET 1 OF 7 FOR REVISIONS	12V305LV-DC
00B	5-20-13	PBS	NAGL	JDWE	SEE SHEET 1 OF 6 FOR REVISIONS	12V305LV-DC
00A	8-13-12	TWV	JDW	JDWE	SEE SHEET 1 OF 5 FOR REVISIONS	12V305LV-DC

TITLE NET-ACCESS N TYPE CABINET 800mm WIDE X 1200mm DEEP FAMILY						
CUSTOMER DRAWING						
ITEM REVISION NAME 12V305LV/02.PRT			DATASET FILE NAME 12V305LV_DC_02A.PRT			
MATERIAL: N/A						
DRAWING NUMBER: 12V305LV-DC						 THIRD ANGLE PROJECTION
DRAWN BY TWV	DATE 8-13-12	CHK JDW	SCALE NONE	SHT 5 OF 6		
SIZE A						

2

1

THIS COPY IS PROVIDED ON A RESTRICTED BASIS AND IS NOT TO BE USED IN ANY WAY DETRIMENTAL TO THE INTERESTS OF PANDUIT CORP.

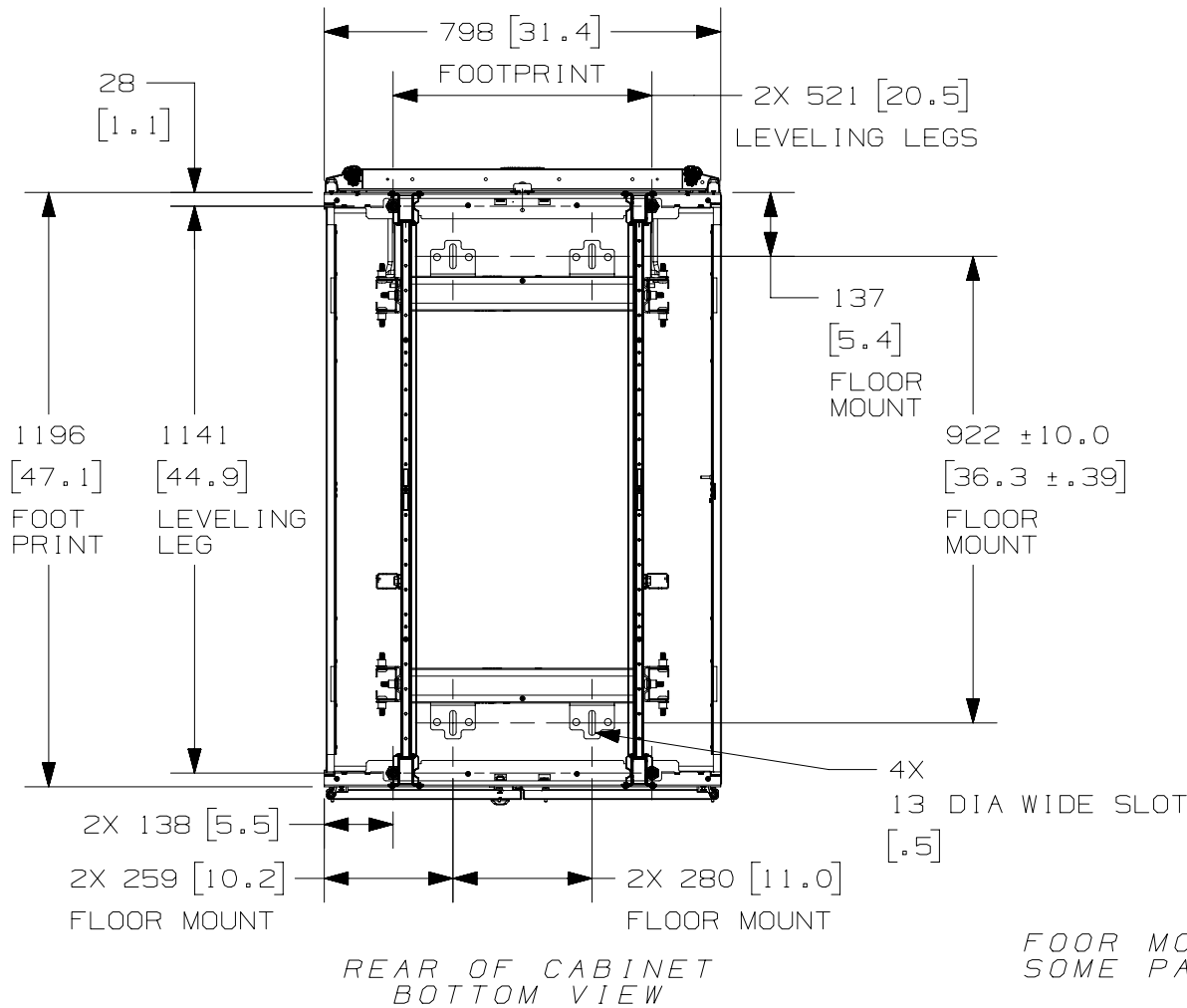

REV	DATE	BY	CHK	APR	DESCRIPTION	ECN
02A	08-25-20	RAMA	ELE	ELE	SEE SHEET 1 OF 7 FOR REVISIONS	V09000BX
01B	02-10-16	SSP	DDW	TCN	SEE SHEET 1 OF 7 FOR REVISIONS	V09000TW
01A	12-11-14	PBS	ADP	TCN	SEE SHEET 1 OF 7 FOR REVISIONS	V09000BX
00C	12-17-13	PBS	ROJC	JDWE	SEE SHEET 1 OF 7 FOR REVISIONS	12V305LV-DC
00B	5-20-13	PBS	NAGL	JDWE	SEE SHEET 1 OF 6 FOR REVISIONS	12V305LV-DC
00A	8-13-12	TWV	JDW	JDWE	SEE SHEET 1 OF 5 FOR REVISIONS	12V305LV-DC

TITLE		NET-ACCESS N TYPE CABINET 800mm WIDE X 1200mm DEEP FAMILY	
CUSTOMER DRAWING			
ITEM REVISION NAME		12V305LV/02.PRT	
DATASET FILE NAME		12V305LV_DC_02A.PRT	
MATERIAL:		N/A	
DRAWING NUMBER:		12V305LV-DC	
THIRD ANGLE PROJECTION			
DRAWN BY	DATE	CHK	SCALE
TWV	8-13-12	JDW	NONE
SHT 6 OF 6		A	