

PANDUIT PART NUMBER	FIGURE	CONDUCTOR RANGE	DIMENSIONS - IN [mm] ±.1 [2.5]			BOLT DIA	WRENCH SIZE
			L	W	H		
GM-1-Q	1	8 SOL - 4 STR	1.25 [32]	1.00 [25]	1.63 [41]	3/8"	9/16"
GM-2-Q	1	4 SOL - 2/0 STR	1.63 [41]	1.13 [29]	1.75 [45]	3/8"	9/16"
GM-3-Q	1	2/0 SOL - 250 kcmil	2.13 [54]	1.50 [38]	2.00 [51]	1/2"	3/4"
GM-3E-X	2	4 SOL - 300 kcmil	1.96 [50]	1.50 [38]	2.32 [59]	1/2"	3/4"
GM-4-X	2	300 kcmil - 500 kcmil	2.38 [60]	1.63 [41]	2.50 [63]	1/2"	3/4"

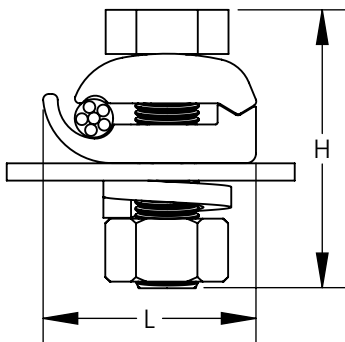
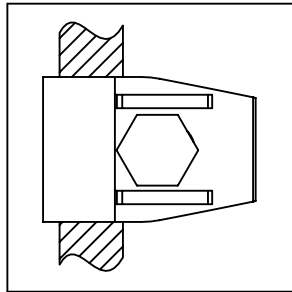
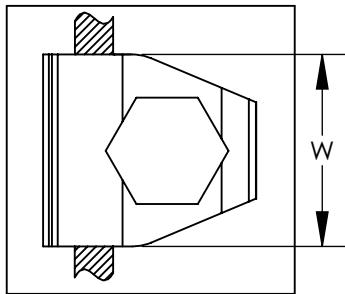

FIGURE 1

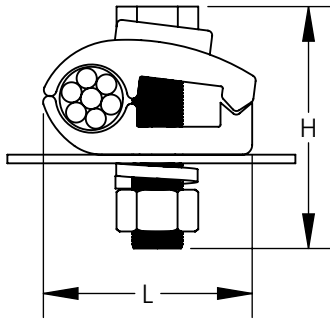

FIGURE 2

NOTES:

1. MADE FROM HIGH COPPER CONTENT ALLOY. FURNISHED WITH FULL THREADED SILICON BOLT, NUTS, AND LOCKWASHERS.
2. THESE CONNECTORS ARE UL LISTED FOR GROUNDING AND BONDING, AND DIRECT BURIAL APPLICATIONS.
3. SEE www.PANDUIT.com FOR PACKAGE QUANTITIES.



DB RATED

REV	DATE	BY	CHK	APR	DESCRIPTION	ECN
07	4/20	JHNU	RGB	RGB	ADDED WRENCH SIZE TO TABLE	N41169BB-C41169
06	8/18	JHNU	JHNU	RGB	REMOVED GM-5-5, GM-6-5	N41169BB-C41169
05	7/18	JHNU	JHNU	RGB	ADDED GM-1-Q, GM-4-X, GM-3E-X, GM-5-5, GM-6-5	038340
04	11/15	JHNU	JHNU	RGB	REVISED WIRE RANGE FOR GMS-3-Q: 2/0 SOL WAS 2/0 STR	N41169BB-C41169

TITLE BRONZE GROUND CLAMP GM SERIES CUSTOMER DRAWING			
ITEM REVISION NAME N41169BB/07			
DATASET FILE NAME N41169BB-C41169/07.SLDDRW			
UNLESS OTHERWISE SPECIFIED, DIMENSIONAL TOLERANCES ARE: IN [mm] .X ± .XXX ± .XX ± ANGLES ±			
DRAWN BY ED	DATE 10/95	CHK WJB	SCALE N/A
DRAWING NUMBER C41169			SHEET 1 OF 1
MATERIAL SEE NOTES			SIZE A