

## 1 Fixation murale Fix to the wall

Montage avec gaines  
 Mounting with sheaths

Protéger les fils jusqu'à l'entrée du produit.  
 Use the wires till the product input.

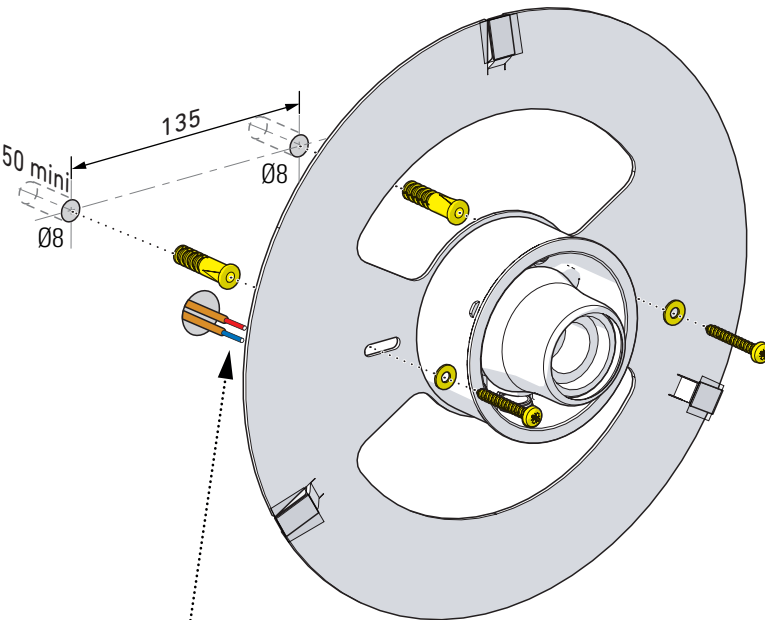

**!** Ne pas dénuder les fils d'alimentation  
 Do not strip the wires

Longueur des cables : 100mm  
 length of cables

## 2 Raccordement électrique Connect electrical wires

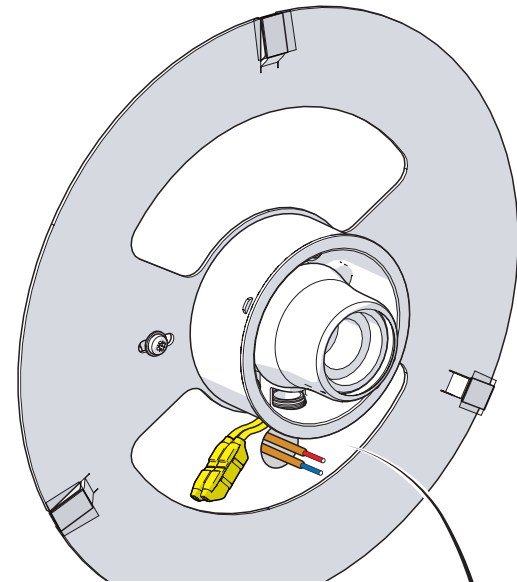

1 Insérer le fil **non dénudé** jusqu'au fond du bornier.  
 Insert **unstripped** wire until it bottoms on the stop.

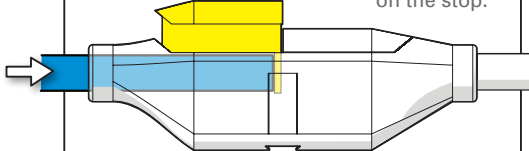

2 Presser le bouton jusqu'à alignement avec le haut du boîtier.  
 Press the button till it flush with the top of housing.

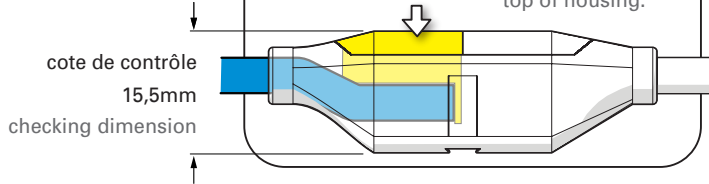

## 3 Collage de la façade Stick the front part

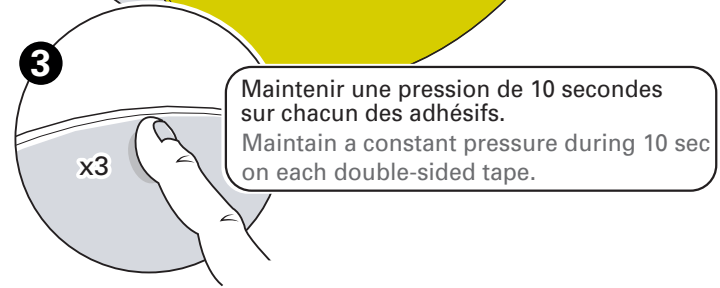
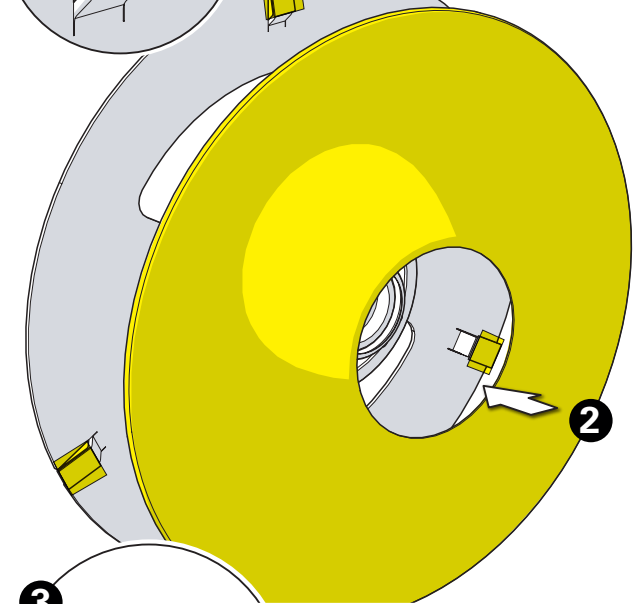
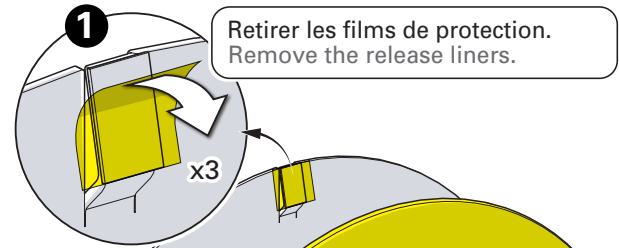

**4** Montage lampe et verrine  
Install the bulb and the glass diffuser

