

Square

Class 1
LED

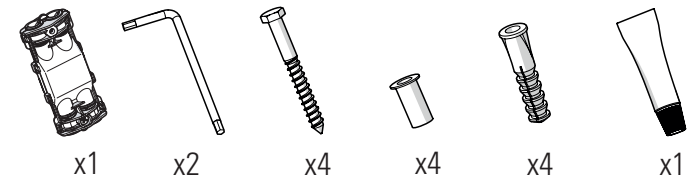

546B-FRND1156007

1 Fixation de la base au sol Fix the mast base to the ground

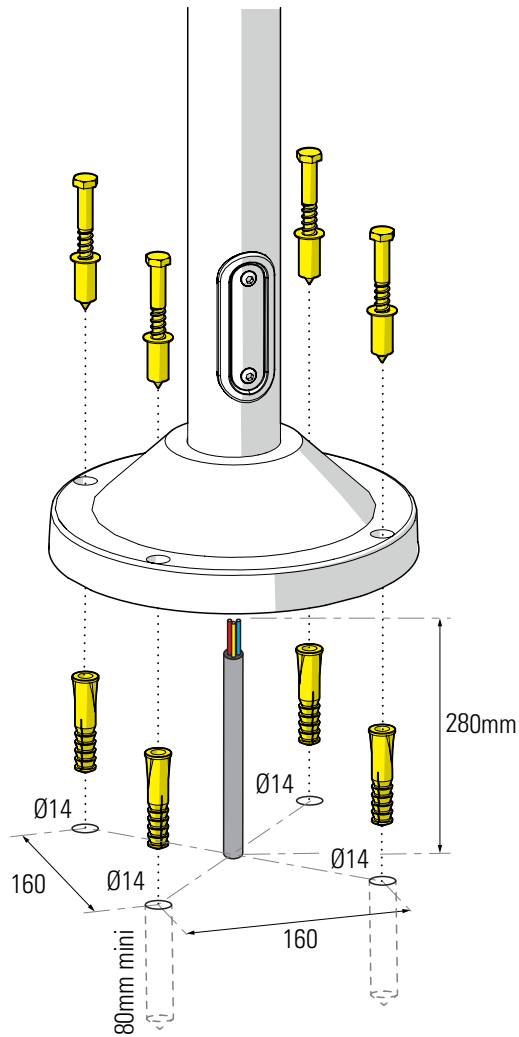

2 Montage de la lampe & du globe Install the light-bulb & globe

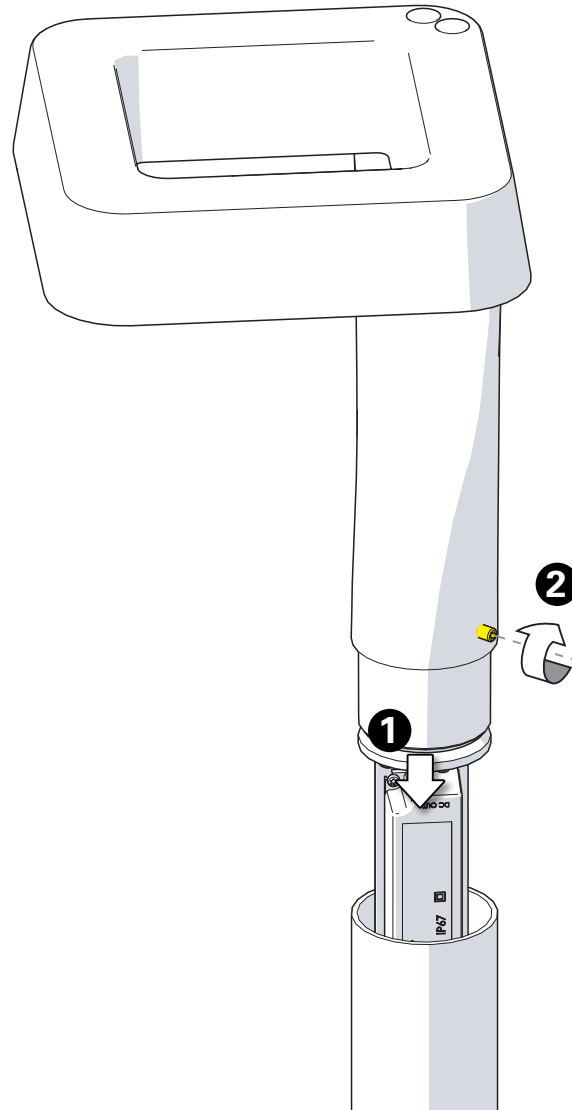

3 Raccordement électrique Connect electrical wires

