

A
These dimensions will be especially checked at delivery
Only inspection dimensions
With /E marked dimensions are only valid for internal use

B
These dimensions will be especially checked at delivery
Only inspection dimensions
With /E marked dimensions are only valid for internal use

C
Diese Maße werden bei Abnahme besonders geprüft
Ausschließlich Prüfmaße
Mit /E gekennzeichnete Maße sind nur für interne Zwecke gültig

D
Diese Maße werden bei Abnahme besonders geprüft
Ausschließlich Prüfmaße
Mit /E gekennzeichnete Maße sind nur für interne Zwecke gültig

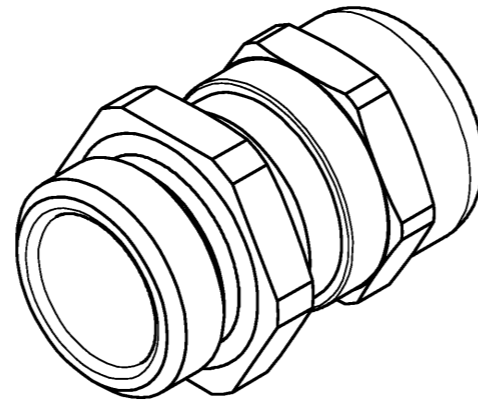
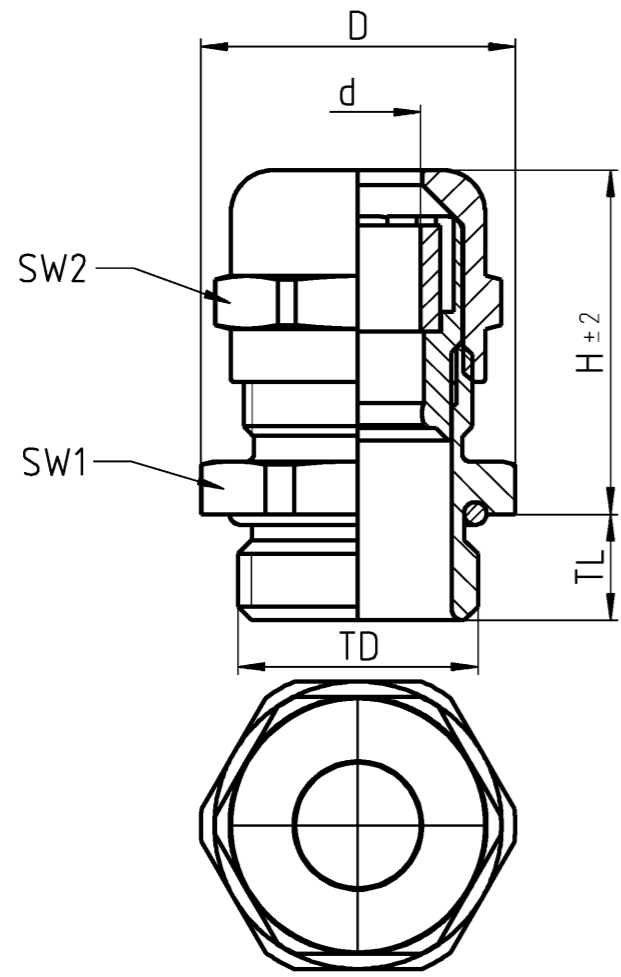

Wieland Teilenummer part number	Gewinde Verschraubung thread type of fitting	Gewinde Schraubkappe thread type of cap	Klemmbereich clamping range Ø min-max mm	Gewinde-Ø thread-Ø TD mm	Gewindelänge thread length TL mm	Höhe ohne Gew.länge height without thread H mm	Verschraubung fitting SW1 mm	Schraubkappe cap SW2 mm	Außen-Ø outer-Ø D mm max.	Innen-Ø inner-Ø D mm max.
Z5.503.6119.0	M16	PG 9	4,0-8,0	16	7	23	19	17	20,8	Ø14,4
Z5.503.6219.0	M20	PG 13,5	6,0-12,0	20	8	26	22	22	24,5	Ø16,4
Z5.503.6319.0	M25	PG 16	10,0-14,0	25	8	27,5	27	24	29,6	Ø18,4
Z5.503.6419.0	M32	PG 21	13,0-18,0	32	9	32,5	36	30	39	Ø18,4
Z5.503.6519.0	M40	PG 29	18,0-25,0	40	9	40,6	46	41	51,4	Ø25,5

nach/according to	DIN EN 62444 / VDE 0619
Gewinde gemäß/thread according to	EN 60423
Material Verschraubung/material fitting	AISI 303 / PA 6 UL94-V2
Material Verschraubungsdichtung/material seal of fitting	CR
Material O-Ring/material O-ring	NBR
Schutzklasse nach/protection class according to	DIN EN 60529 IP 66-68

frei von lackbenetzungsstörenden Substanzen (Silikonfrei)/
free from substances that prevent paint adhesion (silicon free)

Weitere Daten siehe KATALOG oder eKatalog
additional data see CATALOG or eCATALOG
www.wieland-electric.com
eshop.wieland-electric.com

Tolerierung Size ISO 14405 © / Tolerance system Size ISO 14405 ©. (This ISO-standard describes the envelope principle. According to the envelope principle the deviations of form and parallelism are limited by the size tolerances).		ja/yes <input checked="" type="checkbox"/> Stoffverbots- und Deklarationsliste nach WN 5020.010 ist einzuhalten. Conformity with Wieland document WN 5020.010 e (list of prohibited / declarable hazardous substances) to be declared!	
Freitoleranz nach General tolerance	CAD - Zeichnung, keine manuellen Änderungen CAD - drawing, no manual modifications allowed	1 Verwendung: First Use:	Blatt: Sheet: 1 von 1 of 1
Werkstoff / Material	Tag/Date	Name	Zeichnung Nr. / Drawing No.
gezeichnet drawn	09.05.2017	Butterhof	T Z5.503.6119.0 13K a
geprüft checked			
Normgepr. Stand. check			
Maßstab / Scale	Maße in mm / Dimensions are in mm		Index
2:1			a
Vol. mm ³	Ofl./Srf. mm ²	Ersatz für / Replacement for:	
		Type	Benennung/Title
			KABELVERSCHRAUBUNG Metrisch, Edelstahl metric, stainless steel
Index	Datum / Blatt Date / Sheet	www.wieland-electric.com	
Änderung / Revision			