



# FFUC20-1N1IO

FFU

ULTRASONIC FLOWMETER

**SICK**  
Sensor Intelligence.



Illustration may differ



## Ordering information

Type	Part no.
FFUC20-1N1IO	6058038

Other models and accessories → [www.sick.com/FFU](http://www.sick.com/FFU)

## Detailed technical data

### Features

<b>Measurement principle</b>	Ultrasonic sensor
<b>Medium</b>	Fluids
<b>Nominal width measuring tube</b>	DN 20
<b>Process temperature</b>	0 °C ... +80 °C
<b>Process pressure</b>	≤ 10 bar

### Performance

<b>Minimum flow</b>	≥ 3.5 l/min <sup>1)</sup>
<b>Maximum flow</b>	0 l/min ... 60 l/min
<b>Inlet zone</b>	40 cm
<b>Output zone</b>	10 cm
<b>Conductivity</b>	No limitation
<b>Measurement accuracy</b>	± 1 % of measured value +/- 0.15% of measuring range limit value (with calibration log) <sup>2)</sup>
<b>Repeatability</b>	≤ 0.5 %
<b>Resolution</b>	0.012 l/min
<b>Calibration certificate</b>	✓

<sup>1)</sup> At constant flow rate.

<sup>2)</sup> Reference condition: Water, zero gas, measuring tube completely full, no cavitation, temperature of medium 20 °C, ambient temperature 20 °C ... 25 °C, compliance with inlet and outlet zones, warm-up time for electronics: 30 min.

### Electronics

<b>Supply voltage</b>	18 V DC ... 30 V DC <sup>1)</sup>
<b>Residual ripple</b>	≤ 5 V <sub>pp</sub> <sup>2)</sup>
<b>Power consumption</b>	≤ 180 mA <sup>3)</sup>
<b>Initialization time</b>	≤ 5 s

<sup>1)</sup> All connections are polarity protected. All outputs are overload and short-circuit protected.

<sup>2)</sup> May not exceed or fall below U<sub>v</sub> tolerances.

<sup>3)</sup> Without load.

<sup>4)</sup> There are 100 mA for each output PNP and NPN available.

<sup>5)</sup> Analog output and display.

<b>Protection class</b>	III
<b>Connection type</b>	Round connector M12 x 1, 5-pin
<b>Output signal</b>	Analog output 4 mA ... 20 mA, 0 mA ... 20 mA current flow and temperature1 pulse/status output PNP/NPN-transistor output for flow rate meter, empty pipe detection, flow monitoring, dosing output, flow direction (dependent on type) <sup>1)</sup>
<b>Output current</b>	< 100 mA <sup>4)</sup>
<b>Output load</b>	< 500 Ohm
<b>Lower signal level</b>	3.8 mA ... 4 mA
<b>Upper signal level</b>	20 mA ... 20.5 mA
<b>Impuls/frequency output</b>	0 kHz ... 10 kHz
<b>Puls width</b>	≤ 1 s
<b>Inductive load</b>	1 H
<b>Capacitive load</b>	100 nF
<b>Response time</b>	Filter off 100 ms, filter low 300 ms, filter medium 1 s, filter strong 4.2 s <sup>5)</sup>

<sup>1)</sup> All connections are polarity protected. All outputs are overload and short-circuit protected.

<sup>2)</sup> May not exceed or fall below  $U_v$  tolerances.

<sup>3)</sup> Without load.

<sup>4)</sup> There are 100 mA for each output PNP and NPN available.

<sup>5)</sup> Analog output and display.

## Mechanics

<b>Process connection</b>	1" NPT
<b>Wetted parts</b>	PPSU EPDM
<b>Housing material</b>	PPSU
<b>Enclosure rating</b>	IP67
<b>Weight</b>	420 g

## Ambient data

<b>Ambient operating temperature</b>	0 °C ... +60 °C
<b>Ambient temperature, storage</b>	-20 °C ... +70 °C

## Classifications

<b>ECLASS 5.0</b>	27200412
<b>ECLASS 5.1.4</b>	27200412
<b>ECLASS 6.0</b>	27200412
<b>ECLASS 6.2</b>	27200412
<b>ECLASS 7.0</b>	27200412
<b>ECLASS 8.0</b>	27200412
<b>ECLASS 8.1</b>	27200412
<b>ECLASS 9.0</b>	27200412
<b>ECLASS 10.0</b>	27200412
<b>ECLASS 11.0</b>	27200412
<b>ECLASS 12.0</b>	27200412
<b>ETIM 5.0</b>	EC002580

# FFUC20-1N1IO | FFU

ULTRASONIC FLOWMETER

<b>ETIM 6.0</b>	EC002580
<b>ETIM 7.0</b>	EC002580
<b>ETIM 8.0</b>	EC002580
<b>UNSPSC 16.0901</b>	41112501

## Dimensional drawing (Dimensions in mm (inch))

DN 20, G 1

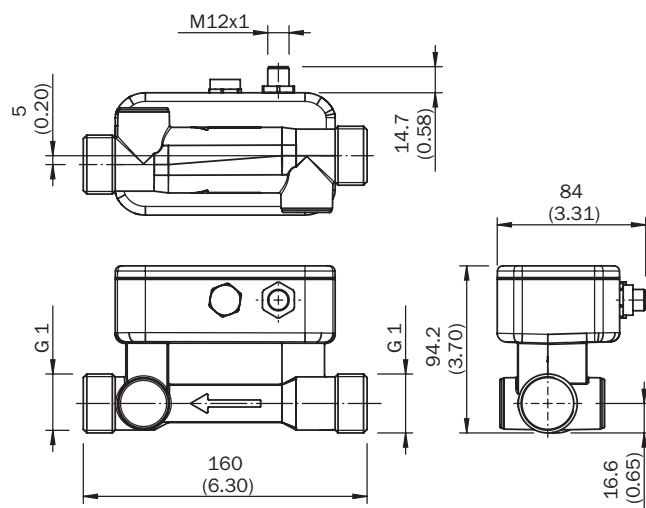

## Connection type

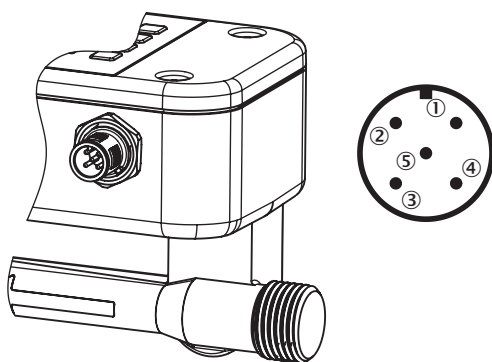

- ① L<sup>+</sup>: Supply voltage
- ② Q<sub>1</sub>: Digital output PNP/NPN
- ③ M: Ground
- ④ C: Communication
- ⑤ Q<sub>A</sub>: Analog current output

## SICK AT A GLANCE

SICK is one of the leading manufacturers of intelligent sensors and sensor solutions for industrial applications. A unique range of products and services creates the perfect basis for controlling processes securely and efficiently, protecting individuals from accidents and preventing damage to the environment.

We have extensive experience in a wide range of industries and understand their processes and requirements. With intelligent sensors, we can deliver exactly what our customers need. In application centers in Europe, Asia and North America, system solutions are tested and optimized in accordance with customer specifications. All this makes us a reliable supplier and development partner.

Comprehensive services complete our offering: SICK LifeTime Services provide support throughout the machine life cycle and ensure safety and productivity.

For us, that is “Sensor Intelligence.”

## WORLDWIDE PRESENCE:

Contacts and other locations –[www.sick.com](http://www.sick.com)