

THIS COPY IS PROVIDED ON A RESTRICTED BASIS AND IS NOT TO BE USED IN ANY WAY DETRIMENTAL TO THE INTERESTS OF PANDUIT CORP.

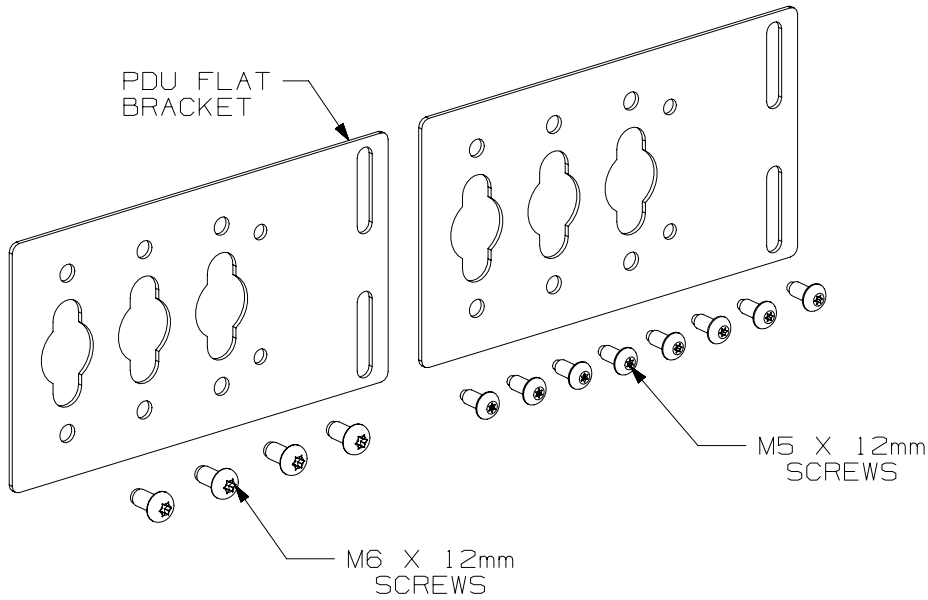

NOTES:

1. PRIMARY DIMENSIONS ARE IN MILLIMETERS.
2. RoHS COMPLIANT.
3. PARTS SUPPLIED:
  - 2- PDU FLAT BRACKET
  - 8- M5 x 12mm SCREWS
  - 4- M6 x 12mm SCREWS
- 1- INSTALLATION INSTRUCTION (NOT SHOWN)

PANDUIT PART NO.	WEIGHT
MA021*	0.9 LBS/EACH 0.43 Kg/EACH

NOTE: \* DENOTES COLOR - ADD SUFFIX " " FOR BLACK AND "W" FOR WHITE.

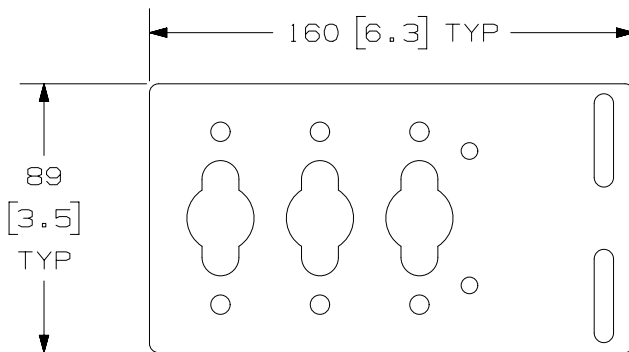

PART NUMBER		MA021*		
TITLE		PDU FLAT eBRACKET		
CUSTOMER DRAWING				
ITEM REVISION NAME		00935NAE/01		
DATASET FILE NAME		00935NAE_DC/01A		
MATERIAL		N/A		
DRAWING NUMBER		00935NAE - DC		
DRAWN BY		DATE	CHK	SCALE
MEX-JAGC		1/25/19	DWR	NONE
SHEET 1 OF 1		A		

REV	DATE	BY	CHK	APR	DESCRIPTION	ECN
01A	4/11/19	MEX-JAGC	DWR	ABUR	REVISED HARDWARE	V09001VT/04
00B	2/26/19	MEX-JAGC	DWR	ABUR	PANDUIT PART NO. NOTE UPDATED	V09001VT/02

A-SIZE CUSTOMER