

THIS COPY IS PROVIDED ON A RESTRICTED BASIS AND IS NOT TO BE USED IN ANY WAY DETRIMENTAL TO THE INTERESTS OF PANDUIT CORP.

PANDUIT PART #	DIM. "A"	VERTICAL MOUNT RAILS	M6 SCREWS	EXTERNAL TOOTH WASHERS	WEIGHT
PZWMC12RR	21.1" [536]	2	4	4	2.7LBS [1.22Kgs]/PAIR
PZWMC18RR	29.8" [756]	2	6	6	3.9LBS [1.77Kgs]/PAIR
PZWMC26RR	45.6" [1158]	2	8	8	5.7LBS [2.59Kgs]/PAIR

NOTES:

- VISIT OUR ON-LINE CATALOG AT WWW.PANDUIT.COM FOR A LIST OF CURRENT PARTS APPLICABLE FOR USE WITH THIS PRODUCT.
- COMPONENTS (SEE TABLE FOR QUANTITIES):
 VERTICAL MOUNTING RAILS
 M6 THREAD FORMING SCREWS
 EXTERNAL TOOTH LOCKWASHERS
- DIMENSIONS IN PARENTHESES ARE METRIC (mm).
- RACK SPACES DEPENDENT ON PART NUMBER. SEE TABLE.
- TICK MARKS AND NUMBERS ARE PROVIDED FOR RACK SPACE IDENTIFICATION.

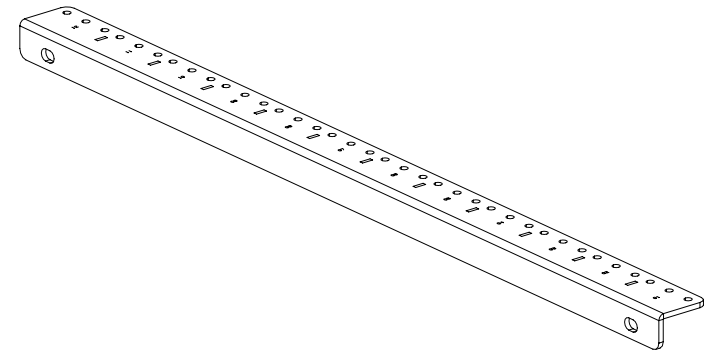
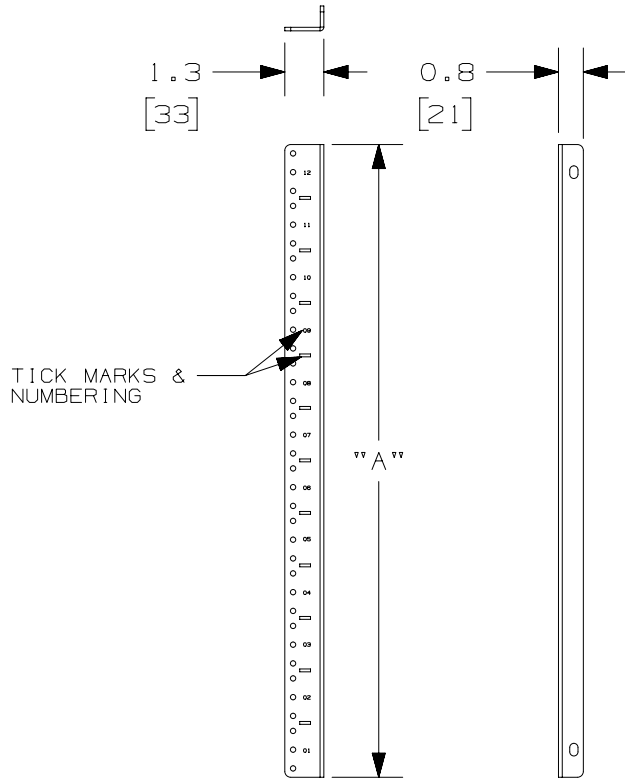

PZWMC12RR SHOWN FOR EXAMPLE:
(SEE TABLE FOR OTHER PART NUMBERS)

TITLE VERTICAL MOUNTING REAR EQUIPMENT RAILS FOR WALL MOUNT CABINETS CUSTOMER DRAWING								
ITEM REVISION NAME 00158LAF/02				PANDUIT				
DATASET FILE NAME 00158LAF_DC/02A								
UNLESS OTHERWISE SPECIFIED, DIMENSIONAL TOLERANCES ARE: IN (mm)				MATERIAL: STEEL				
DRAWN BY: TWV DATE: 7-31-17 CHK: KZU SCALE: NONE				DRAWING NUMBER: 00158LAF - DC				
REV	DATE	BY	CHK	APR	DESCRIPTION	ECN	SHT 1 OF 1	SIZE A

REV	DATE	BY	CHK	APR	DESCRIPTION	ECN
02A	01-18-19	MDJR	KZU	MINO	ADDED DOCUMENTATION FOR 18" AND 26"	00158LAF-DC
01A	7-31-17	TWV	KZU	JEFK	RELEASED TO PRODUCTION	00158LAF-DC