

2

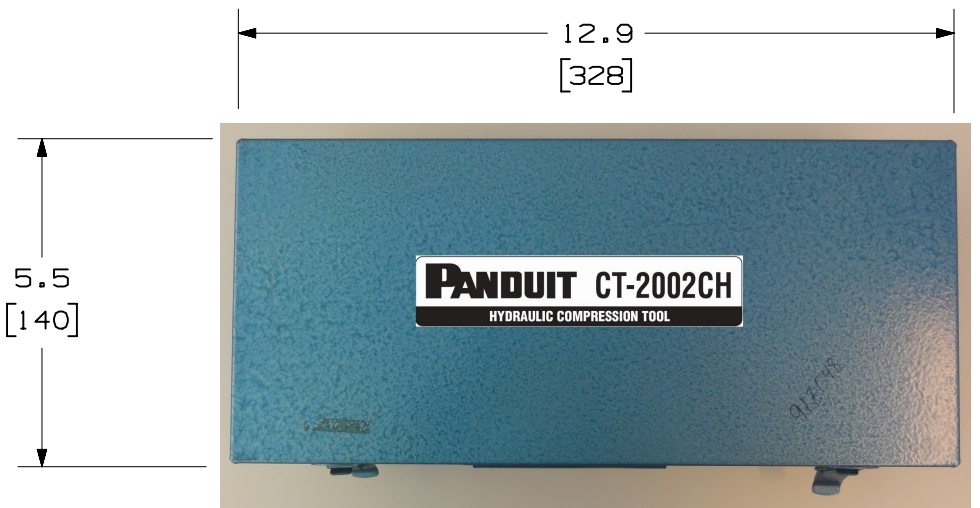

1

THIS COPY IS PROVIDED ON A RESTRICTED BASIS AND IS NOT TO BE USED IN ANY WAY DETRIMENTAL TO THE INTERESTS OF PANDUIT CORP.

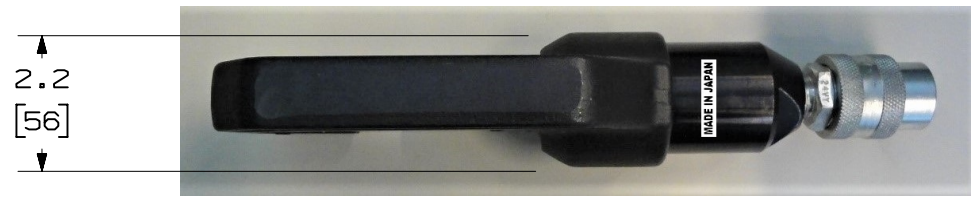
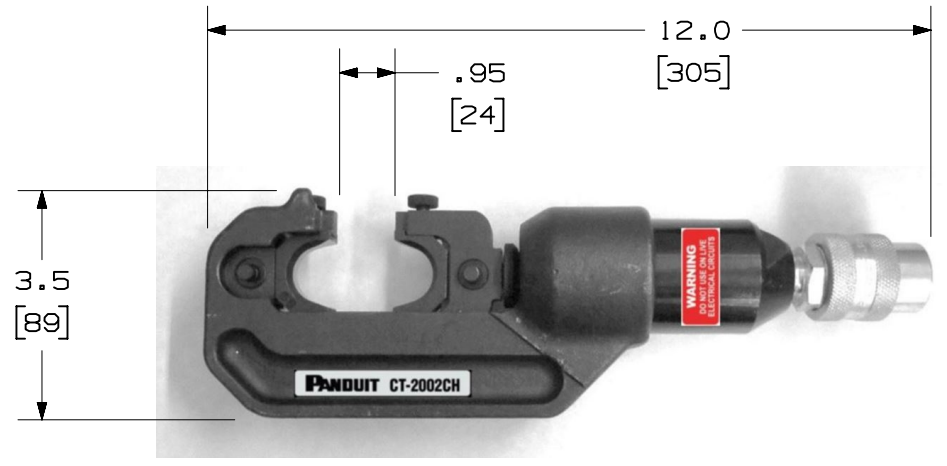

NOTES: UNLESS OTHERWISE SPECIFIED

TOOL OUTPUT: 6 TONS (5.4 METRIC TONS)
 TOOL WEIGHT: 6 lbs. (2.7 kg)
 DIMENSIONS: LENGTH HEIGHT WIDTH
 12.0" x 3.5" x 2.2"
 (305 mm x 89 mm x 56 mm)

PANDUIT PART NO.: CT-2002CH

TOOL KIT INCLUDES: - CRIMP HEAD
 - METAL CARRYING CASE

JAW OPENING: .95" (24.1mm)

APPLICABLE PANDUIT CONNECTOR RANGE:
 GO TO www.panduit.com FOR MORE INFORMATION.

TOOL TO BE USED WITH PANDUIT HYDRAULIC PUMP, HOSES, ACCESSORIES
 AND CRIMP DIES. GO TO www.panduit.com FOR MORE INFORMATION.

WARNING: TOOL SHOULD NOT BE USED ON LIVE CIRCUITS

B

B



A

A

01	06.07.18	BDK	ALP	ALP	RELEASED TO PRODUCTION	034720	
REV	DATE	BY	CHK	APR	DESCRIPTION	ECN	

CT-2002CH 6 TON HYDRAULIC CRIMP HEAD CUSTOMER DRAWING			
ITEM REVISION NAME		R29259BA/01	
DATASET FILE NAME		R29259BA_TP29259B01/01	
UNLESS OTHERWISE SPECIFIED, DIMENSIONAL TOLERANCES ARE: IN [mm]		PANDUIT MATERIAL:	
.X ± ---- .XXX ± ---- .XX ± ---- ANGLES ± ----		THIRD ANGLE PROJECTION DRAWING NUMBER: TP29259B01	
DRAWN BY	DATE	CHK	SCALE
BDK	05.10.18	ALP	N.T.S.
SHT 1 OF 1			SIZE B

2



1

N:\GLOBAL_BS\SIZE