

THIS COPY IS PROVIDED ON A RESTRICTED BASIS AND IS NOT TO BE USED IN ANY WAY DETRIMENTAL TO THE INTERESTS OF PANDUIT CORP.

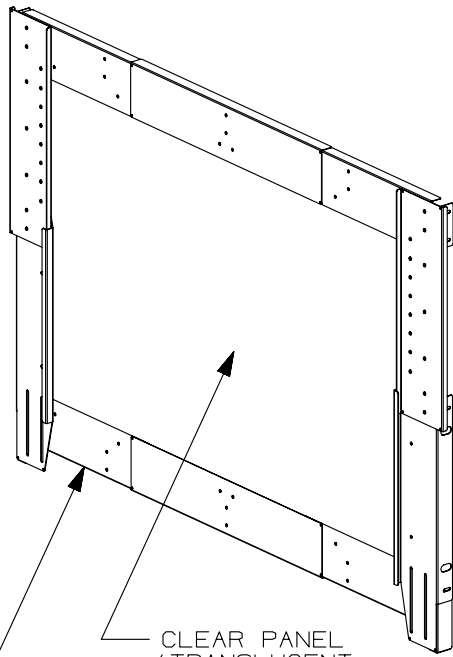

CLEAR PANEL
(TRANSLUCENT
TWIN WALL
POLYCARBONATE)

FRAME STRUCTURE

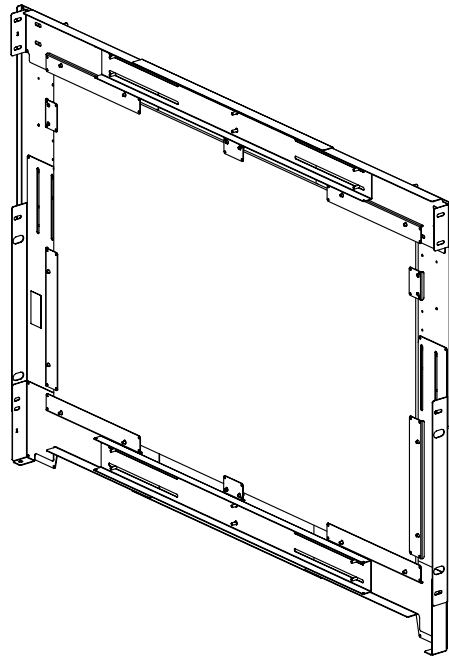

NOTES:

1. VISIT OUR ONLINE CATALOG AT WWW.PANDUIT.COM FOR A LIST OF CURRENT PARTS APPLICABLE FOR USE WITH THIS PRODUCT.
2. PRIMARY DIMENSIONS ARE METRIC (mm). DIMENSIONS IN PARENTHESES ARE INCHES (IN).
3. FIRE RATING: NON-METALLIC PARTS ARE CONSTRUCTED WITH MATERIALS THAT COMPLY WITH NFPA 75.
4. FRAME STRUCTURE SHIPPED UNASSEMBLED.
5. PARTS SUPPLIED (ASSEMBLY REQUIRED):

C2HACER11626XX AND C2HACER12638XX

- 1 - FRAME STRUCTURE
- 1 - CLEAR PANEL
- 1 - HARDWARE KIT (NOT SHOWN)

C2HACER13866XX

- 1 - FRAME STRUCTURE
- 2 - CLEAR PANELS
- 1 - H CHANNEL (NOT SHOWN)
- 1 - HARDWARE KIT (NOT SHOWN)

PANDUIT PART NO.	HEIGHT RANGE	WEIGHT
C2HACER11626XX	406mm (16") - 660mm (26")	9.7 Kg (21.4 LBS) EA.
C2HACER12638XX	660mm (26") - 965mm (38")	13.2 Kg (29.0 LBS) EA.
C2HACER13866XX	965mm (38") - 1676mm (66")	16.8 Kg (37.0 LBS) EA.

*XX = COLOR
B1 = BLACK
W1 = WHITE

REV	DATE	BY	CHK	APR	DESCRIPTION	ECN
00A	09/10/13	ERK			RELEASED	12V284MB

TITLE NET-CONTAIN™ HOT AISLE CONTAINMENT END OF ROW WALL FOR N OR S TYPE CABINETS CUSTOMER DRAWING			
ITEM REVISION NAME		12V284MB/00	
DATASET FILE NAME		12V284MB_DC/00A	
MATERIAL:		N/A	
DRAWING NUMBER:		12V284MB	
DRAWN BY	DATE	CHK	SCALE
ERK	09/10/13		N/A
SHT 1 OF 3		A	

THIS COPY IS PROVIDED ON A RESTRICTED BASIS AND IS NOT TO BE USED IN ANY WAY DETRIMENTAL TO THE INTERESTS OF PANDUIT CORP.

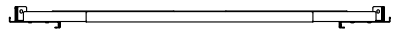

TOP VIEW COLLAPSED

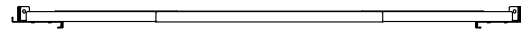

TOP VIEW EXPANDED

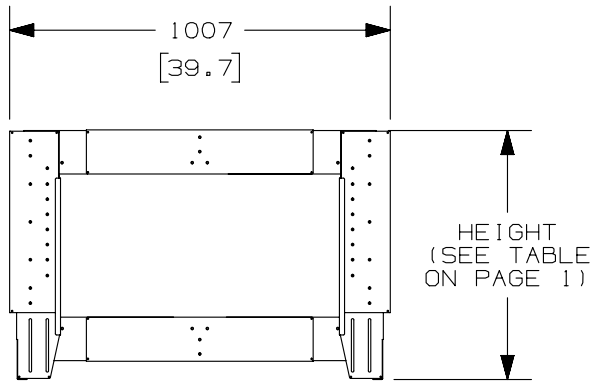

FRONT VIEW COLLAPSED

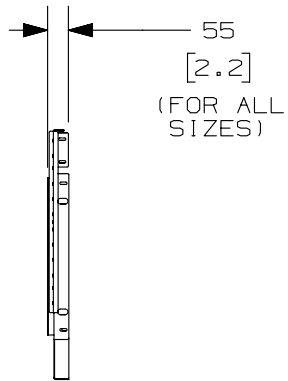

SIDE VIEW COLLAPSED

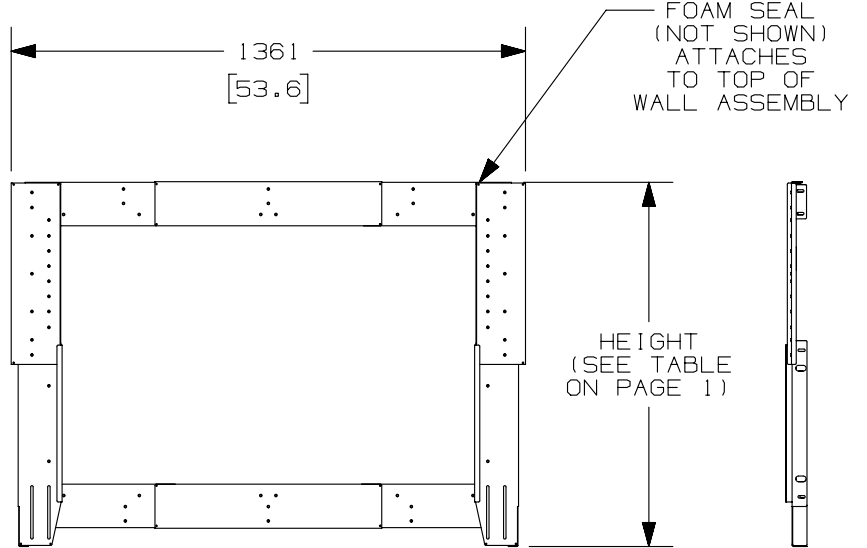

FRONT VIEW EXPANDED

SIDE VIEW EXPANDED

--	---	--	--	--	SEE SHEET 1 OF 3 FOR REVISIONS	12V284MB

TITLE NET-CONTAIN™ HOT AISLE CONTAINMENT END OF ROW WALL FOR N OR S TYPE CABINETS CUSTOMER DRAWING			
ITEM REVISION NAME 12V284MB/00		PANDUIT	
DATASET FILE NAME 12V284MB_DC/00A			
MATERIAL: N/A		DRAWING NUMBER: 12V284MB	

REV	DATE	BY	CHK	APR	DESCRIPTION	ECN	DRAWN BY	DATE	CHK	SCALE	SHT 2 OF 3	SIZE
							ERK	09/10/13		N/A		A

THIS COPY IS PROVIDED ON A RESTRICTED BASIS AND IS NOT TO BE USED IN ANY WAY DETRIMENTAL TO THE INTERESTS OF PANDUIT CORP.

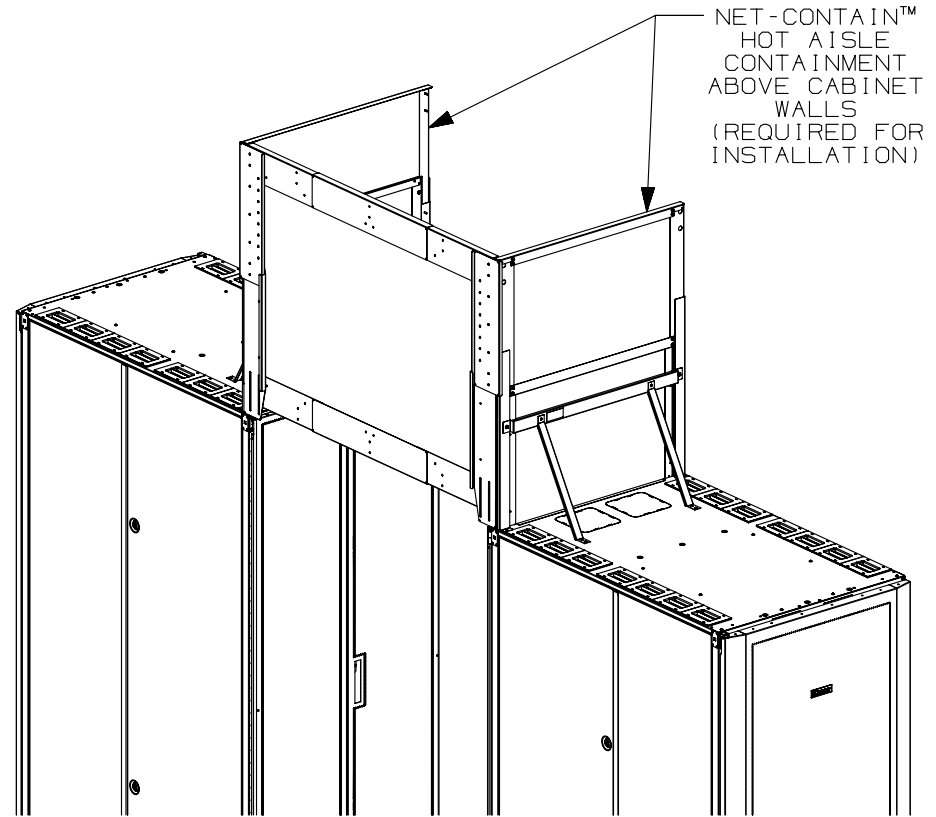
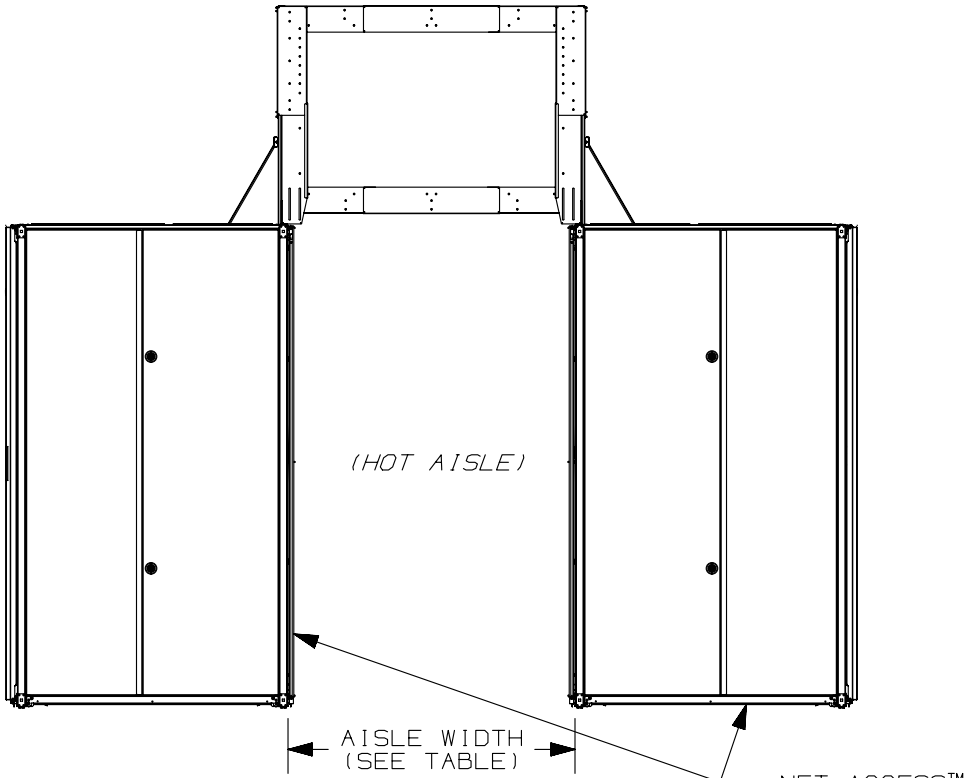

AISLE WIDTH COMPATIBILITY	
MILLIMETERS (± 13)	INCHES (± 0.5)
912 - 960	35.9 - 37.8
1000	39.4
1208 - 1266	47.6 - 49.8

TITLE		NET-CONTAIN™ HOT AISLE CONTAINMENT END OF ROW WALL FOR N OR S TYPE CABINETS										
ITEM REVISION NAME		CUSTOMER DRAWING										
DATASET FILE NAME		12V284MB/00	PANDUIT									
		12V284MB_DC/00A										
MATERIAL:		N/A										
DRAWING NUMBER:		12V284MB										
REV	DATE	BY	CHK	APR	DESCRIPTION	ECN	DRAWN BY	DATE	CHK	SCALE	SHT 3 OF 3	SIZE
--	---	--	--	--	SEE SHEET 1 OF 3 FOR REVISIONS	12V284MB	ERK	09/10/13		N/A		A