



MPS-G50CFH13E31DZZ

MPS-G

POSITION SENSORS

SICK
Sensor Intelligence.



Ordering information

Type	Part no.
MPS-G50CFH13E31DZZ	1127845

Other models and accessories → www.sick.com/MPS-G



Detailed technical data

Features

Cylinder type	C-slot
Preferred manufacturer slot	Festo, Zimmer, Gimatic
Detection zone	0 mm ... 50 mm ¹⁾
Cylinder types with adapter	T-slot cylinders Round body cylinder Profile cylinders and tie-rod cylinders
Measuring range	50 mm
Housing length	25 mm
Switching output	2 x push-pull: PNP/NPN
Output function	IO-Link
Electrical wiring	DC 4-wire
Enclosure rating	IP67
Adjustment	
	Teach-in button
	IO-Link
	Initialization of dynamic teach for 1 to 3 switching points Manual programming of 1 to 3 switching points (digital outputs) Adjustment of overrun distance per switching point Resetting of switching points
	Configuration of up to 8 switching points
Diagnostic functionality	Actuator diagnosis
Special features	Completely embedded mounting in the slot, providing protection

¹⁾ Deviations are possible depending on the drive.

Mechanics/electronics

Supply voltage	10 V DC ... 30 V DC
Voltage drop	≤ 1 V

¹⁾ ≤ 200 mA (PUSH); ≥ -200 mA (PULL).

²⁾ The sensor must not be subjected to magnetic fields strengths of > 20 mT!

³⁾ For measuring range > 37 mm, the following applies for the resolution: Measuring range / 3,723.

⁴⁾ At 25 ° C, linearity error (maximum deviation) depending on response curve and minimal deviation function.

⁵⁾ At 25 ° C, repeatability magnet movement in one direction.

Continuous current I_a	≤ 200 mA ¹⁾
Protection class	III
Time delay before availability	0.175 s
Power consumption	≤ 550 mW
Required magnetic field sensitivity, typ.	2 mT ... 20 mT ²⁾
Overrun distance	Configurable
Hysteresis	Configurable
Resolution, typ.	0,01 mm ³⁾
Linearity error, typ.	0.3 mm ⁴⁾
Repeat accuracy, typ.	0.05 mm ⁵⁾
Sampling rate, typ.	1 ms
Reverse polarity protection	Yes
Short-circuit protection	Yes
Status indicator LED	Yes
Digital switching output	Yes
Teach-in	Yes
Ambient operating temperature	-20 °C ... +70 °C
Shock and vibration resistance	30 g, 11 ms / 10 ... 55 Hz, 1 mm
EMC	According to EN 60947-5-2
Connection type	Cable with connector M12, with knurled nuts, 0.3 m
Connection type Detail	
Conductor cross section	0.08 mm ²
Cable diameter	Ø 2.6 mm
Bending radius	For flexible use > 10 x cable diameter With fixed installation > 5 x cable diameter
Cable outlet	Axial
Control elements connection cable	
Connection type	Cable, 4-wire, 0.1 m
Control elements connection cable detail	
Conductor size	0.09 mm ²
Cable diameter	Ø 2.2 mm
Bending radius	For flexible use > 10 x cable diameter With fixed installation > 5 x cable diameter
Cable outlet	Axial
Material	
Housing	Plastic, PA, strengthened
Cable	PUR
Control element	Plastic, TPU, reinforced

¹⁾ ≤ 200 mA (PUSH); ≥ -200 mA (PULL).

²⁾ The sensor must not be subjected to magnetic fields strengths of > 20 mT!

³⁾ For measuring range > 37 mm, the following applies for the resolution: Measuring range / 3,723.

⁴⁾ At 25 °C, linearity error (maximum deviation) depending on response curve and minimal deviation function.

⁵⁾ At 25 °C, repeatability magnet movement in one direction.

Safety-related parameters

MTTF_D	358 years
DC_{avg}	0 %
T_M (mission time)	20 years

Communication interface

Communication interface	IO-Link V1.1
Communication Interface detail	COM3
Cycle time	1 ms
Process data length	32 Bit
Process data structure	Bit 0 ... 7 = switching signal Qint1 - Qint8 (or up to 8 alarm notifications) Bit 16 ... 31 = position (in x10 µm)

Diagnosis

Actuator diagnosis	
Status data	Cycle count, travel time, cylinder travel, dwell time, piston velocity, alarm notifications
Magnetic field strength	2 mT ... 18 mT

Classifications

ECLASS 5.0	27270104
ECLASS 5.1.4	27270104
ECLASS 6.0	27270104
ECLASS 6.2	27270104
ECLASS 7.0	27270104
ECLASS 8.0	27270104
ECLASS 8.1	27270104
ECLASS 9.0	27270104
ECLASS 10.0	27270104
ECLASS 11.0	27270104
ECLASS 12.0	27274301
ETIM 5.0	EC002544
ETIM 6.0	EC002544
ETIM 7.0	EC002544
ETIM 8.0	EC002544
UNSPSC 16.0901	39122230

Installation note

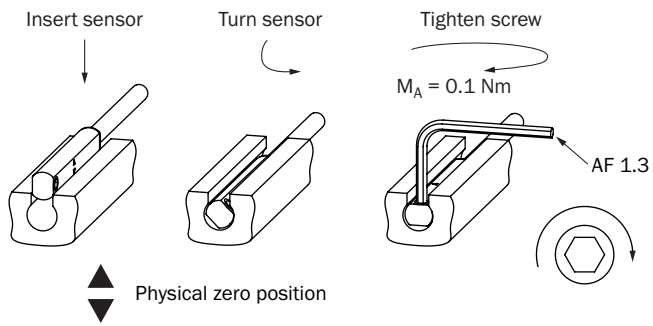

Connection diagram

Cd-466

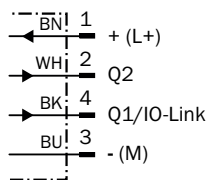

Dimensional drawing (Dimensions in mm (inch))

Cable with connector M12, with knurled nuts

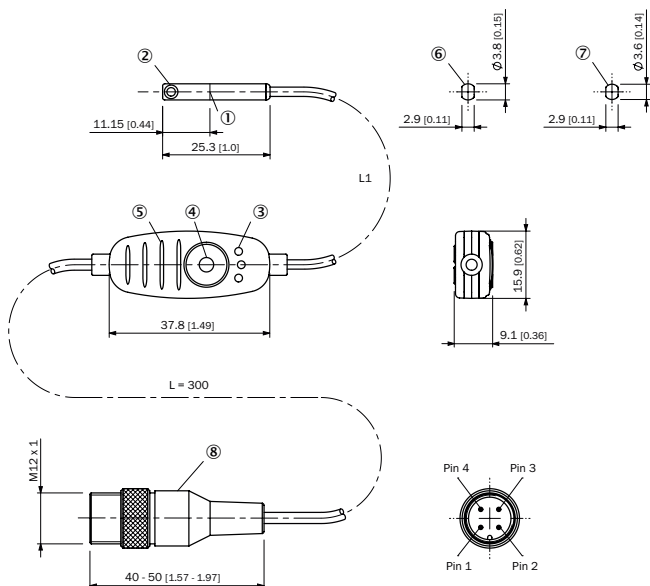









- ① Center of sensor element
- ② Fixing screw SW 1.3
- ③ Display LED
- ④ Teach-in button
- ⑤ Ribbing for cable ties
- ⑥ For SMC, Schunk, PHD, Bimba slot (MPS-G50CS...)
- ⑦ For Festo, Zimmer, Gimatic slot (MPS-G50CF...)
- ⑧ Connection

Part no.	Type	L1	Number of cores
1127845	MPS-G50CFH13E31DZZ	100 mm	4
1127846	MPS-G50CSH13E31DZZ	100 mm	4
1127847	MPS-G50CSH53E31DZZ	500 mm	4

Recommended accessories

Other models and accessories → www.sick.com/MPS-G

	Brief description	Type	Part no.
Connection modules			
	IO-Link V1.1 Class A port, USB2.0 port, optional external power supply 24V / 1A	IOLA2US-01101 (SiLink2 Master)	1061790
Brackets for cylinder sensors			
	Mounting is by means of the enclosed adhesive pad, 2x M3 countersunk screws or 2x cable ties, plastic, including double-sided adhesive pad	BEF-CPMPS-G	2117133
	Preferred manufacturer slot Festo, SMC, Pneumax, Airtec, plastic	BEF-KHZ-TC3	2117770
Plug connectors and cables			
	<ul style="list-style-type: none"> • Connection type head A: Male connector, M12, 4-pin, straight • Description: Unshielded • Connection systems: Screw-type terminals • Permitted cross-section: ≤ 0.75 mm² 	STE-1204-G	6009932
Sensor Integration Gateway			
	<ul style="list-style-type: none"> • Further functions: Web server integrated, IIoT interface available (dual talk) • Logic editor: no • Communication interface: IO-Link, Ethernet, PROFINET, REST API, MQTT, OPC UA • Product category: IO-Link Master 	SIG350-0004AP100	6076871
	<ul style="list-style-type: none"> • Further functions: Web server integrated, IIoT interface available (dual talk) • Logic editor: no • Communication interface: IO-Link, Ethernet, EtherNet/IP™, REST API, MQTT, OPC UA • Product category: IO-Link Master 	SIG350-0005AP100	6076923
	<ul style="list-style-type: none"> • Further functions: Web server integrated, IIoT interface available (dual talk) • Logic editor: no • Communication interface: IO-Link, Ethernet, EtherCAT®, REST API, MQTT, OPC UA • Product category: IO-Link Master 	SIG350-0006AP100	6076924
	<ul style="list-style-type: none"> • Further functions: Web server integrated, USB connection for easy configuration of the SIG200 Sensor Integration Gateway with SOPAS ET, the engineering tool from SICK, logic editor is available for easy configuration of logic functions • Connection CONFIG: 1 x M8, 4-pin female connector, USB 2.0 (USB-A) • Logic editor: yes • Communication interface: IO-Link, USB, Ethernet, PROFINET, REST API • Product category: IO-Link Master 	SIG200-0A0412200	1089794

	Brief description	Type	Part no.
	<ul style="list-style-type: none"> • Description: The SIG200 Sensor Integration Gateway is an IO-Link master with 4 configurable ports through which the IO-Link devices or standard inputs or standard outputs can be connected to a PLC or cloud application using the REST API. • Further functions: Web server integrated, USB connection for easy configuration of the SIG200 Sensor Integration Gateway with SOPAS ET, the engineering tool from SICK, logic editor is available for easy configuration of logic functions • Connection CONFIG: 1 x M8, 4-pin female connector, USB 2.0 (USB-A) • Logic editor: yes • Communication interface: IO-Link, USB, Ethernet, EtherNet/IP™, REST API • Product category: IO-Link Master 	SIG200-0A0512200	1089796
	<ul style="list-style-type: none"> • Further functions: Web server integrated, USB connection for easy configuration of the SIG200 Sensor Integration Gateway with SOPAS ET, the engineering tool from SICK, logic editor is available for easy configuration of logic functions • Connection CONFIG: 1 x M8, 4-pin female connector, USB 2.0 (USB-A) • Logic editor: yes • Communication interface: IO-Link, USB, Ethernet, REST API • Product category: IO-Link Master 	SIG200-0A0G12200	1102605

SICK AT A GLANCE

SICK is one of the leading manufacturers of intelligent sensors and sensor solutions for industrial applications. A unique range of products and services creates the perfect basis for controlling processes securely and efficiently, protecting individuals from accidents and preventing damage to the environment.

We have extensive experience in a wide range of industries and understand their processes and requirements. With intelligent sensors, we can deliver exactly what our customers need. In application centers in Europe, Asia and North America, system solutions are tested and optimized in accordance with customer specifications. All this makes us a reliable supplier and development partner.

Comprehensive services complete our offering: SICK LifeTime Services provide support throughout the machine life cycle and ensure safety and productivity.

For us, that is “Sensor Intelligence.”

WORLDWIDE PRESENCE:

Contacts and other locations –www.sick.com