

THIS COPY IS PROVIDED ON A RESTRICTED BASIS AND IS NOT TO BE USED IN ANY WAY DETRIMENTAL TO THE INTERESTS OF PANDUIT CORP.

NOTES:

1. SEE CATALOG FOR COMPLETE LIST OF PARTS APPLICABLE FOR USE WITH THIS PART.
2. DIMENSIONS IN BRACKETS ARE METRIC.
3. MATERIAL: GALVANNEALED STEEL
COLOR: BLACK
WEIGHT: 0.85 lb (0.39 kg)
4. TOOLLESS MOUNTING TO REAR OF HD FLEX ENCLOSURE.
5. ALL MATERIALS AND COMPONENTS USED MEET THE MATERIAL RESTRICTIONS OF RoHS (EUROPEAN DIRECTIVE 2011/65/EC ON THE RESTRICTION OF HAZARDOUS SUBSTANCES) AS PROPOSED BY THE RoHS TECHNICAL ADAPTATION COMMITTEE.

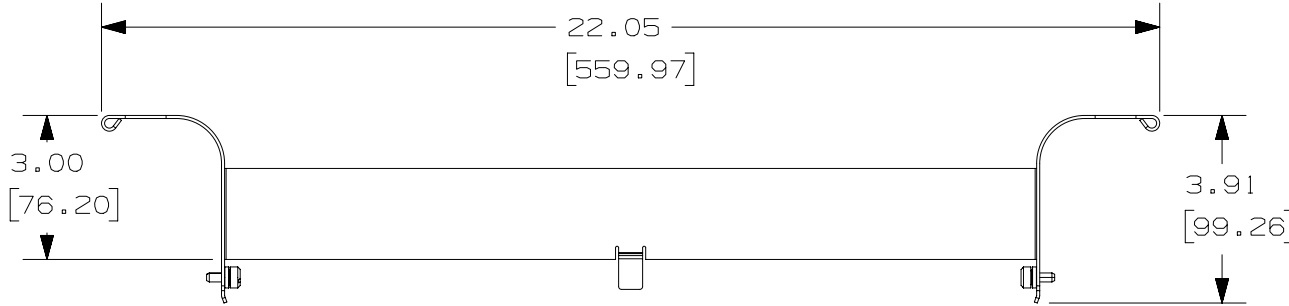

TOP VIEW

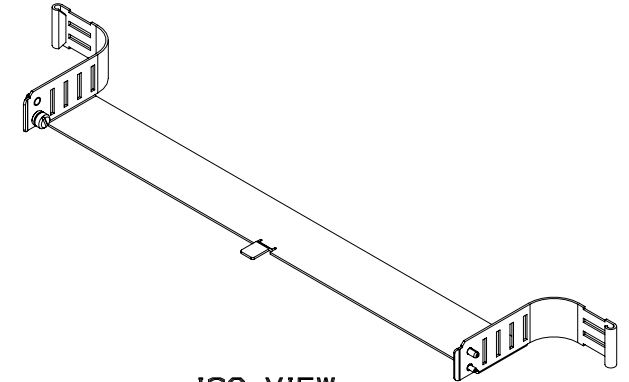

ISO VIEW

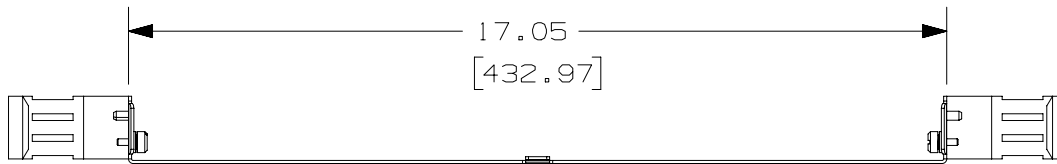

FRONT VIEW

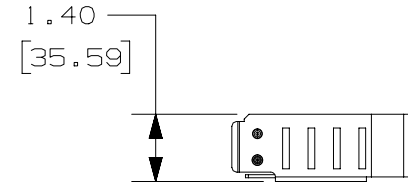

LEFT SIDE VIEW

						TITLE						
						HD FLEX 1RU REAR SLACK MANAGEMENT PLATE (SHORT)						
						CUSTOMER DRAWING						
						ITEM REVISION NAME						
						12F187UB/02						
						DATASET FILE NAME						
						12F187UB_DC/02A						
						UNLESS OTHERWISE SPECIFIED, DIMENSIONAL TOLERANCES ARE: IN (mm)						
						.X ± .xxx ± .010 (0.3)						
						.XX ± .03 (0.8) ANGLES ±						
						PART NO.						
						FLEX-RCM1U						
						DRAWING NUMBER:						
						12F187UB-DC						
O2A	05-25-17	SAT	JDK	AW	RELEASED TO PRODUCTION	12F187UB-DC						
REV	DATE	BY	CHK	APR	DESCRIPTION	ECN	DRAWN BY	DATE	CHK	SCALE	SHT 1 OF 1	SIZE
							SAT	10-19-15	JDK	1 : 4		A