



PICS150-01000 Core-1

picoScan100

2D LIDAR SENSORS

SICK
Sensor Intelligence.



Ordering information

Type	Part no.
PICS150-01000 Core-1	1134608

Other models and accessories → www.sick.com/picoScan100



Detailed technical data

Features

Variant	Standard (not pre-configured)
Measurement principle	HDDM ⁺
Application	Indoor
Light source	Infrared (905 nm)
Laser class	1 (IEC 60825-1:2014, EN 60825-1:2014+A11:2021)
Aperture angle	Horizontal 276°
Scanning frequency	15 Hz 25 Hz Depends on the Dynamic Sensing Profile ¹⁾
Angular resolution	1° 0.33° 0.25° Depends on the Dynamic Sensing Profile ¹⁾
Scan field flatness	± 1°
Working range	0.05 m ... 25 m ¹⁾
Blind zone	0 m ... 0.05 m
Scanning range	At 90% remission and 10 klx 25 m At 10% remission and 10 klx 12 m
Spot size	Divergence, typ.: 4.8 mrad On the optics cover: 8 mm
Amount of evaluated echoes	3

¹⁾ For details, see the working range diagram in the technical drawings section.

Mechanics/electronics

System plug	See system plug 2116047
Supply voltage	9 V DC ... 30 V DC
Power consumption	Typ. 4.5 W, max. 17 W with loaded digital outputs, see system plug 2116047
Output current	≤ 200 mA
Housing	Aluminum with Suretec650 coating
Housing color	Anthracite gray (RAL 7016)
Optical hood	Polycarbonate, scratch-resistant coating
Enclosure rating	IP65 (IEC 60529:1989+AMD1:1999+AMD2:2013) ¹⁾ IP67 (IEC 60529:1989+AMD1:1999+AMD2:2013) ¹⁾
Protection class	III (IEC 61140:2016-11)
Electrical safety	IEC 61010-1:2010-06+AMD1:2016
Weight	220 g, without system plug
Dimensions (L x W x H)	60 mm x 60 mm x 82 mm
Ventilation element	Yes
MTBF	> 100 years

¹⁾ With system plug connected.

Safety-related parameters

MTTF_D	> 100 years, at 25 °C ambient temperature (EN ISO 13849-1:2015)
-------------------------	---

Performance

Data output per scan segment	Segment size 30° at ≤ 25 Hz
Scan/frame rate	12,546 measurement point/s ... 82,803 measurement point/s, Depends on the Dynamic Sensing Profile and number of echoes
Latency of the measurement data output	Segment size 30° at < 25 Hz: ≤ 10 ms (3 σ), Depends on the Dynamic Sensing Profile and number of echoes
Detectable object shape	Almost any
Systematic error	Typ. ± 20 mm ¹⁾ Max. ± 30 mm
Statistical error	≤ 2 mm (0.05 m ... 5 m) ²⁾
Integrated application	Output of measurement data 2D Object Detection
Digital add-ons	Data Reduction & Data Preparation package

¹⁾ Typical value; real value depends on ambient conditions and the selected Dynamic Sensing Profile.

²⁾ 10 klx and 100 klx.

Software functions

Dynamic Sensing Profile package	-
Data Reduction & Data Preparation package	Included (Moving average filter, Interval filter, Scan range filter, Rectangular filter, Distance filter)
Reliability package	Included (Fog filter, Particle filter)
Multi-echo technology	Included
LMDscandata (data format)	Included
Reflector detection	Included
IMU (Inertial Measurement Unit)	Included

PTP	Included
Interfaces	
Ethernet	✓, UDP/IP (Compact, MSGPACK), TCP/IP (LMDscandata)
Function	Data interface (read result output), OPC DA, NTP, Measured data output (distance, RSSI)
Data transmission rate	10 Mbit/s ... 100 Mbit/s, half/full-duplex
Digital inputs/outputs	3, customizable, see system plug 2116047
Optical indicators	2 LEDs
Configuration software	SOPASair (web browser)SOPAS ET (software)REST API
Driver	ROS1

Ambient data

Object remission	1.8 % ... > 1,000 % (Reflector)
Electromagnetic compatibility (EMC)	
Emitted radiation	Industrial environment (IEC 61000-6-4:2018 / EN IEC 61000-6-4:2019 / IEC 61000-6-4:2006+A1:2010 / EN 61000-6-4:2007+A1:2011)
Emitted radiation	Business and commercial areas as well as small enterprises (IEC 61000-6-8:2020 / EN IEC 61000-6-8:2020)
Electromagnetic immunity	Industrial environment (IEC 61000-6-2:2016 / EN IEC 61000-6-2:2019 / IEC 61000-6-2:2005 / EN 61000-6-2:2005 / EN 61000-6-2:2005/AC:2005)
Vibration resistance	
Sine resonance scan	10 Hz ... 1,000 Hz, 1 g ¹⁾
Sine test	10 Hz ... 500 Hz, 10 g, 10 frequency cycles ¹⁾
Noise test	10 Hz ... 500 Hz, 13.5 g RMS, 5 h ²⁾
	Short restriction in measurement data availability possible during peak loads.
Shock resistance	
	100 g, 6 ms, ± 3 single shocks/axis ³⁾
	40 g, 6 ms, ± 5,000 continuous shocks/axis ³⁾
	50 g, 3 ms, ± 5,000 continuous shocks/axis ³⁾
	Short restriction in measurement data availability possible.
Ambient operating temperature	-33 °C ... +50 °C
Storage temperature	-40 °C ... +70 °C
Temperature change	-33 °C ... +50 °C, 10 cycles ⁴⁾
Damp heat	+25 °C ... +55 °C, 95 % RH, 6 cycles ⁵⁾
Permissible relative humidity	
Operation	< 80 %, Non-condensing (EN 60068-2-30:2005)
Storage	≤ 90 %, Non-condensing (EN 60068-2-30:2005)
Ambient light immunity	100 klx, indirect
Altitude (above sea level)	< 5,000 m

¹⁾ IEC 60068-2-6:2007.

²⁾ IEC 60068-2-64:2008.

³⁾ IEC 60068-2-27:2008.

⁴⁾ EN 60068-2-14:2009.

⁵⁾ EN 60068-2-30:2005.

General notes

Note on use	The sensor does not constitute a safety component as defined by relevant legislation on machine safety.
--------------------	---

Classifications

ECLASS 5.0	27270990
ECLASS 5.1.4	27270990
ECLASS 6.0	27270913
ECLASS 6.2	27270913
ECLASS 7.0	27270913
ECLASS 8.0	27270913
ECLASS 8.1	27270913
ECLASS 9.0	27270913
ECLASS 10.0	27270913
ECLASS 11.0	27270913
ECLASS 12.0	27270913
ETIM 5.0	EC002550
ETIM 6.0	EC002550
ETIM 7.0	EC002550
ETIM 8.0	EC002550
UNSPSC 16.0901	41111615

Dimensional drawing (Dimensions in mm (inch))

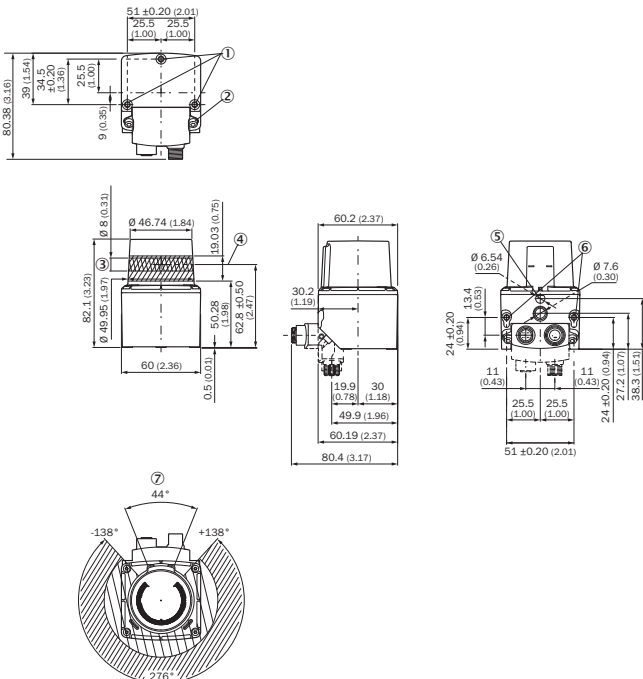

- ① M4 threaded mounting hole; 4.2 mm deep, tightening torque 2.5 nm
- ② Tightening torque 2.5 nm, screw included in plug unit
- ③ Sending area
- ④ Transmission axis
- ⑤ Support point
- ⑥ M4 threaded mounting hole; 5.4 mm deep, tightening torque 2.5 nm
- ⑦ Area in which no reflective surfaces are allowed for mounted devices

Working range diagram

Working range for picoScan150 Core

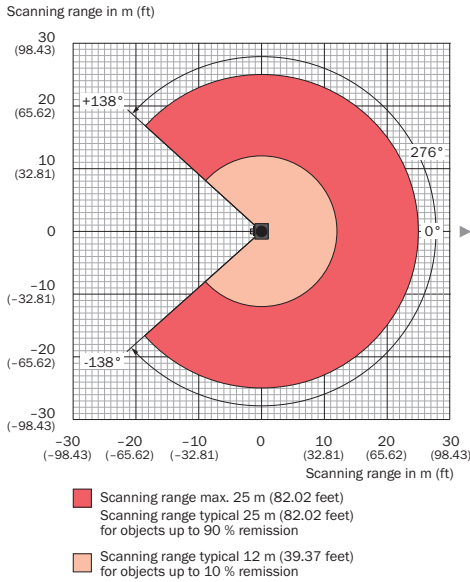

All specified working range values apply to the “Standard” sensitivity mode

Dynamic Sensing Profile	Minimum		Typical			
	100 klx		10 klx		100 klx	
	10 %	90 %	10 %	90 %	10 %	90 %
15 Hz & 0.33 °	10 m	25 m	12 m	25 m	10 m	25 m
25 Hz & 0.25 °	10 m	25 m	12 m	25 m	10 m	25 m

Recommended services

Additional services → www.sick.com/picoScan100

	Type	Part no.
Maintenance		
<ul style="list-style-type: none"> Product area: 2D LiDAR sensors, 3D LiDAR sensors Range of services: Inspection, analysis and restoring of defined functions, Inspection and adaptation of basic settings, parameters of field application, filters for raw data output, and product-specific configuration Duration: Additional work will be invoiced separately Travel expenses: The prices do not include travel costs such as hotel, flight, travel time and expenses. 	Maintenance of LiDAR sensors	1682593
Commissioning		
<ul style="list-style-type: none"> Product area: 2D LiDAR sensors, 3D LiDAR sensors Range of services: Inspection of connection, fine adjustment, configuration of monitored areas, configuration and optimization of parameters as well as tests, Setup of previously defined functions of basic settings, parameters of field application, filters for raw data output and product-specific configuration Travel expenses: The prices do not include travel costs such as hotel, flight, travel time and expenses. Duration: Additional work will be invoiced separately 	Commissioning LiDAR sensors	1680672

SICK AT A GLANCE

SICK is one of the leading manufacturers of intelligent sensors and sensor solutions for industrial applications. A unique range of products and services creates the perfect basis for controlling processes securely and efficiently, protecting individuals from accidents and preventing damage to the environment.

We have extensive experience in a wide range of industries and understand their processes and requirements. With intelligent sensors, we can deliver exactly what our customers need. In application centers in Europe, Asia and North America, system solutions are tested and optimized in accordance with customer specifications. All this makes us a reliable supplier and development partner.

Comprehensive services complete our offering: SICK LifeTime Services provide support throughout the machine life cycle and ensure safety and productivity.

For us, that is “Sensor Intelligence.”

WORLDWIDE PRESENCE:

Contacts and other locations –www.sick.com