

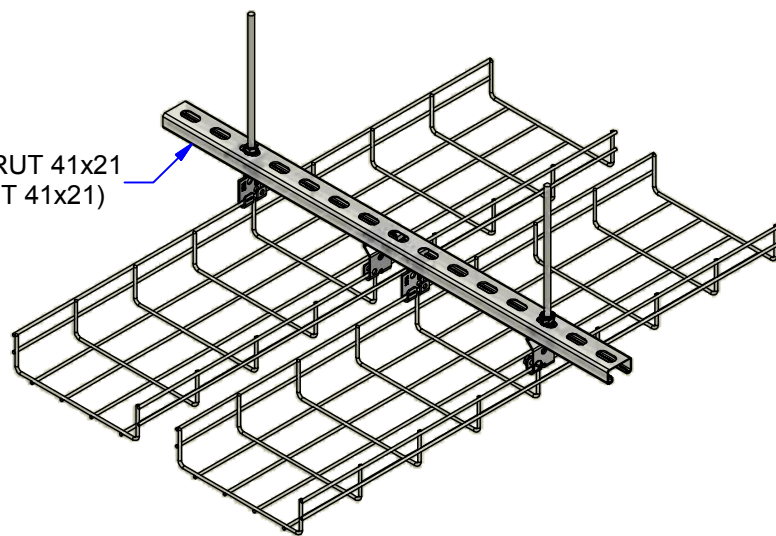

Rail STRUT 41x21  
(STRUT 41x21)

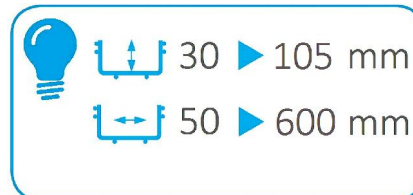

Chemin de câbles fil  
(Mesh tray)



| Description | Code   | Masse/Weight<br>Kg/p | Ep./Th.<br>mm |  daN |
|-------------|--------|----------------------|---------------|---|
| UFA SZ      | 552033 | 0,070                | 2,00          | 100   |

**G** : Pre-galvanised according to NF EN 10346 (S220 GD / Z).

**SZ** : Tôle d'acier galvanisé avant fabrication suivant NF EN 10346 (S220 GD / Z).



www.niedaxfrance.fr

ATTACHE BALANCELLE UFA SZ  
UFA HANGING BRACKET G



ASSISTANCE TECHNIQUE  
+33 (0)1 55 95 92 17  
pole.technique@niedax.fr

FT02406

**NIEDAX**  
France

