

THIS COPY IS PROVIDED ON A RESTRICTED BASIS AND IS NOT TO BE USED IN ANY WAY DETRIMENTAL TO THE INTERESTS OF PANDUIT CORP.

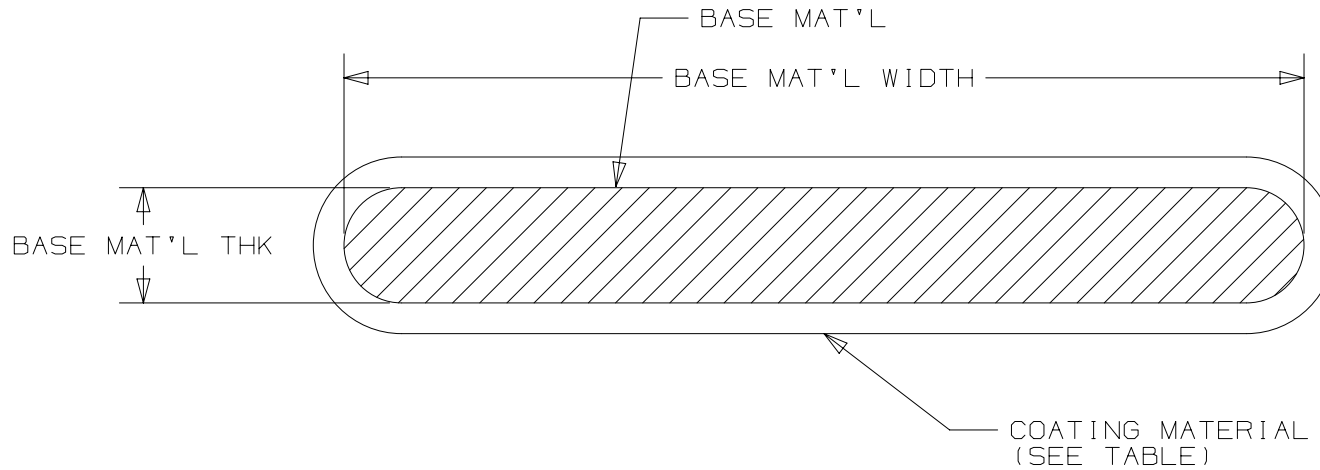

PANDUIT PART NO.	USES BUCKLE PART NO.	COATING MAT'L	BASE MAT'L WIDTH	BASE MAT'L THICKNESS
IMSP9.5T35-QR6L*	IMSBL9.5-C6L	EPOXY POLYESTER	9.5 MM	0.35 MM
IMSP12T35-QR6L*	IMSBL12-C6L	EPOXY POLYESTER	12 MM	0.35 MM
IMSP16T35-QR6L*	IMSBL16-C6L	EPOXY POLYESTER	16 MM	0.35 MM

NOTES:

1. BASE MATERIAL: 316L STAINLESS STEEL.
2. DIMENSIONS ARE IN MM.
3. APPLICATION TOOL: PANDUIT BT75SDT.
4. BAND LENGTH IS 25 METER. NO MARKING ON THE PARTS.
5. COMPATIBLE BUCKLES: SEE TABLE
6. FULLY COATED MATERIAL.
COATING THICKNESS: 0.05MM TO 0.15MM PER SIDE.
7. * STANDS FOR SUFFIX LETTER OF OPTIONAL COLORS: B = BLUE.

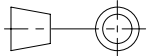
REV	DATE	BY	CHK	APR	DESCRIPTION	ECN	TITLE					
							IMSP COATED STAINLESS STEEL BANDS					
							CUSTOMER DRAWING					
							ITEM REVISION NAME 15L322BJ/02		PANDUIT			
							DATASET FILE NAME 15L322BJ_DC/02					
02	6/1/2016	JSUN	SKB	RGRO	ADD NOTE 7 OPTIONAL COLOR	15L322BJ_DV/02	UNLESS OTHERWISE SPECIFIED, DIMENSIONAL TOLERANCES ARE: MM .x ± .25 .xx ± .13 ANGLES ± 1 °  THIRD ANGLE PROJECTION			MATERIAL: POLYESTER EPOXY COATED 316L STAINLESS STEEL STRAPPING DRAWING NUMBER: 155L322BJ_DC		
01	03/16	JSUN	SKB	RGRO	CHANGE DWG FORMAT TO A SIZE	15L322BJ_DV/01						
00	11/15	JSUN	SKB	RGRO	DRAWING RELEASE	15L322BJ_DC/00						
							DRAWN BY JSUN	DATE 11-04-2015	CHK SKB	SCALE NONE	SHT 1 OF 1	SIZE A

D10100DA/16