

**KHB0630SE4●**  
**KHB0630SE5●**  
**KHB0630SE4●G**  
**KHB0630SE5●G**

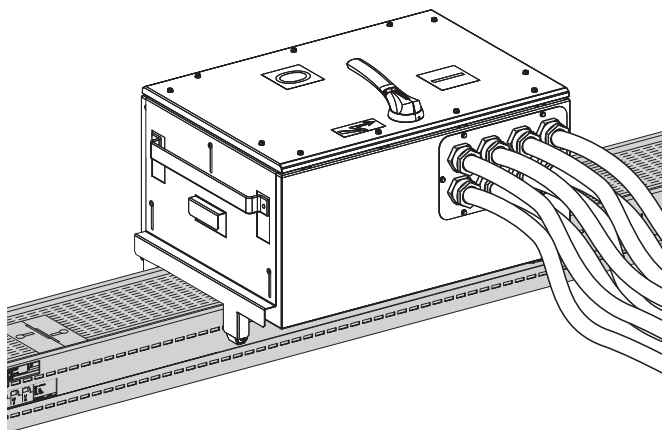

<p><b>PLEASE NOTE</b> Electrical equipment should be installed, operated, serviced, and maintained only by qualified personnel. No responsibility is assumed by Schneider Electric for any consequences arising out of the use of this material.</p>	<p><b>REMARQUE IMPORTANTE</b> L'installation, l'utilisation, la réparation et la maintenance des équipements électriques doivent être assurées par du personnel qualifié uniquement. Schneider Electric décline toute responsabilité quant aux conséquences de l'utilisation de ce matériel.</p>
<p><b>TENGA EN CUENTA</b> La instalación, utilización, puesta en servicio y mantenimiento de equipos eléctricos deberán ser realizados sólo por personal cualificado. Schneider Electric no se hace responsable de ninguna de las consecuencias del uso de este material.</p>	<p><b>BITTE BEACHTEN</b> Elektrische Geräte dürfen nur von Fachpersonal installiert, betrieben, bedient und gewartet werden. Schneider Electric haftet nicht für Schäden, die durch die Verwendung dieses Materials entstehen.</p>
<p><b>NOTA</b> Manutenzione, riparazione, installazione e uso delle apparecchiature elettriche si devono affidare solo a personale qualificato. Schneider Electric non si assume alcuna responsabilità per qualsiasi conseguenza derivante dall'uso di questo materiale.</p>	<p><b>NOTA</b> A instalação, utilização e manutenção do equipamento eléctrico devem ser efectuadas exclusivamente por pessoal qualificado. A Schneider Electric não assume qualquer responsabilidade pelas consequências resultantes da utilização deste material.</p>
<p><b>请注意</b> 电气设备的安装、操作、维修和维护工作仅限于合格人员执行。 Schneider Electric 不承担由于使用本资料所引起的任何后果。</p>	<p><b>ОБРАТИТЕ ВНИМАНИЕ</b> Установка, эксплуатация, ремонт и обслуживание электрического оборудования может выполняться только квалифицированными электриками. Компания Schneider Electric не несет никакой ответственности за любые возможные последствия использования данной документации.</p>

**⚠ ⚠ DANGER / DANGER / PELIGRO / GEFAHR / PERICOLO / PERIGO / 危险 / ОПАСНОСТЬ**

<p><b>HAZARD OF ELECTRIC SHOCK, EXPLOSION, OR ARC FLASH</b> Disconnect all power before servicing equipment. <b>Failure to follow these instructions will result in death or serious injury.</b></p>	<p><b>RISQUE D'ÉLECTROCUTION, D'EXPLOSION OU D'ECLAIR D'ARC ELECTRIQUE</b> Coupez toutes les alimentations avant de travailler sur cet appareil. <b>Si ces directives ne sont pas respectées, cela entraînera la mort ou des blessures graves.</b></p>
<p><b>PELIGRO DE DESCARGA ELÉCTRICA, EXPLOSIÓN O DESTELLO POR ARQUEO</b> Desconecte todas las alimentaciones antes de manipular el producto. <b>El incumplimiento de estas instrucciones podrá causar la muerte o lesiones serias.</b></p>	<p><b>GEFAHR VON ELEKTRISCHEM SCHLAG, EXPLOSION ODER LICHTBOGEN</b> Vor dem Arbeiten am Gerät alle Spannungsversorgungen abschalten. <b>Die Nichtbeachtung dieser Anweisungen führt zu Tod oder schweren Verletzungen.</b></p>
<p><b>RISCHIO DI FOLGORAZIONE, ESPLOSIONI O ARCO ELETTRICO</b> Scollegare l'appare cchioda tutti i circuiti di alimentazione prima di qualsiasi intervento. <b>Il mancato rispetto di queste istruzioni provocherà morte o gravi infortuni.</b></p>	<p><b>RISCO DE ELECTROCUSSÃO, DE EXPLOSIÃO, OU DE ARCO ELÉCTRICO</b> Desconecte todas as alimentações antes de manipular o produto. <b>A não observância destas instruções resultará em morte, ou ferimentos graves.</b></p>
<p><b>电击、爆炸或电弧闪光危险</b> 在此电力设备上工作时,请先切断 所有电源。 <b>不遵循上述说明将导致人员伤亡。</b></p>	<p><b>Опасность поражения электрическим током, опасность взрыва или вспышки дуги.</b> Перед обслуживанием или ремонтом убедитесь, что питание отключено. <b>Несоблюдение этих инструкций приведет к смерти или серьезной травме.</b></p>

**▲ CAUTION / ATTENTION / ATENCIÓN / VORSICHT /  
ATTENZIONE / CUIDADO / 小心 / ВНИМАНИЕ**



**RISK OF CUTTING**

- Store the products in a dedicated and marked area.
- Wear personal protective equipment when handling and installing the products (gloves, long sleeved jacket, trousers, safety shoes, helmet, safety glasses).

**Failure to follow these instructions can result in injury or equipment damage.**

**RISQUE DE COUPURE**

- Stockez les produits dans une zone dédiée et balisée.
  - Utilisez des équipements individuels de protection lors de la manipulation et de l'installation des produits (gants, veste à manches longues, pantalon, chaussures de sécurité, casque, lunettes de sécurité).
- Si ces directives ne sont pas respectées, cela peut entraîner des blessures ou des dommages matériels.**



**RIESGO DE CORTES**

- Almacene los productos en áreas específicas y señalizadas para ello.
- Utilice un equipo de protección personal cuando manipule e instale los productos (guantes, chaqueta de manga larga, pantalones, zapatos de seguridad, casco y gafas de seguridad).

**El incumplimiento de estas instrucciones puede causar lesiones o daño al equipo.**

**GEFÄHRDUNG DURCH SCHNEIDEN**

- Lagern Sie die Produkte im dafür vorgesehenen, gekennzeichneten Bereich.
  - Tragen Sie Schutzkleidung bei der Handhabung und Installation der Produkte (Handschuhe, Jacke mit langen Ärmeln, Hosen, Sicherheitsschuhe, Helm, Schutzbrille).
- Die Nichtbeachtung dieser Anweisungen kann Verletzungen oder Sachschäden zur Folge haben.**



**RISCHIO DI TAGLIO**

- Conservare i prodotti in un'area dedicata e contrassegnata.
- Indossare protezioni individuali adeguate per la manipolazione e l'installazione dei prodotti (guanti, giacche a manica lunga, pantaloni, calzature antinfortunistiche, elmetto, occhiali protettivi).

**Il mancato rispetto di queste istruzioni può provocare infortuni o danni alle apparecchiature.**

**RISCO DE CORTE**

- Armezen os produtos numa área dedicada e assinalada.
  - Use equipamento de protecção pessoal quando manusear e instalar os produtos (luvas, casaco de mangas compridas, calças, calçado de segurança, capacete, óculos de protecção).
- A não observância destas instruções pode provocar ferimentos pessoais, ou danos no equipamento.**



**割伤危险**

- 请在标明的专门区域存储本产品。
  - 搬运和安装产品时请穿戴个人防护装备（手套、长袖夹克、长裤、安全鞋、头盔、护目镜）。
- 不遵循上述说明可能导致人身伤害或设备损坏。**

**РИСК ПОРЕЗОВ**







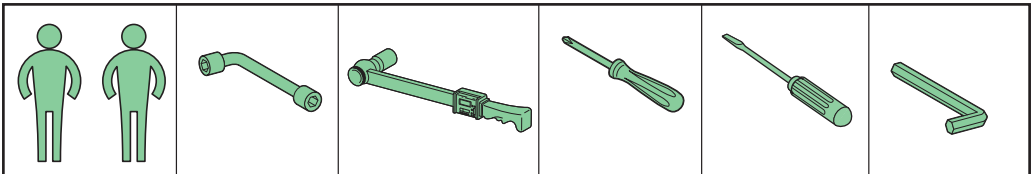

- Храните изделия в специальном месте с маркировкой.
  - Надевайте средства персональной защиты при погрузке-разгрузке и установке изделий (перчатки, куртку с длинными рукавами, брюки, защитную обувь, каску, защитные очки).
- Несоблюдение этих инструкций может привести к травме или повреждению оборудования.**

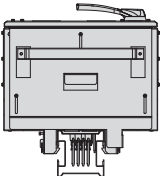

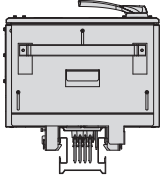
<p>The product's manufacture date is coded as YYWW, where:</p> <ul style="list-style-type: none"> <li>● YY: year of manufacture</li> <li>● WW: week of manufacture</li> </ul> <p>Eg: 1545 = means the product manufactured on week 45 2015.</p>	<p>La date de fabrication du produit est codée sous la forme YYWW, où:</p> <ul style="list-style-type: none"> <li>● YY: année de fabrication</li> <li>● WW: semaine de fabrication</li> </ul> <p>Exemple : 1545 indique un produit fabriqué pendant la semaine 45 de l'année 2015.</p>
<p>La fecha fabricación del producto está codificada como YYWW, donde:</p> <ul style="list-style-type: none"> <li>● YY: año de fabricación</li> <li>● WW: semana de fabricación</li> </ul> <p>P. ej.: 1545 = Producto fabricado en la semana 45 de 2015.</p>	<p>Das Herstellungsdatum des Produkts weist folgendes Format auf: YYWW. Hierbei gilt Folgendes:</p> <ul style="list-style-type: none"> <li>● YY: Herstellungsjahr</li> <li>● WW: Herstellungswoche</li> </ul> <p>Beispiel: 1545 = bezieht sich auf das in Woche 45 2015 hergestellte Produkt.</p>
<p>La data di costruzione del prodotto è codificata come segue YYWW, dove:</p> <ul style="list-style-type: none"> <li>● YY: anno di fabbricazione</li> <li>● WW: settimana di fabbricazione</li> </ul> <p>es.: 1545 = indica il prodotto fabbricato alla settimana 45 del 2015.</p>	<p>A data de fabrico do produto está codificada como YYWW, sendo que:</p> <ul style="list-style-type: none"> <li>● YY: ano de fabrico</li> <li>● WW: semana de fabrico</li> </ul> <p>exemplo: 1545 = significa o produto foi fabricado na semana 45 de 2015.</p>
<p>产品制造日期编码为 YYWW，其中：</p> <ul style="list-style-type: none"> <li>● YY：制造年份</li> <li>● WW：第几周制造</li> </ul> <p>例如：1545 = 表示在 2015 年第 45 周制造的产品。</p>	<p>Дата производства продукта указана в виде кода YYWW, где:</p> <ul style="list-style-type: none"> <li>● YY: год производства;</li> <li>● WW: неделя производства</li> </ul> <p>Пример: Например, 1545 означает, что изделие изготовлено на 45 неделе 2015 года.</p>

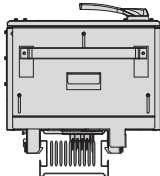

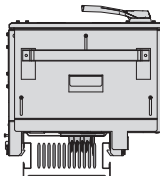
### GS2S 630 A Fuse Holder

<p>KHF14 KHF16 KHF18</p>	<p>KT●●●●●EH●●●</p>	<p>KHF26 KHF28</p>	<p>KHF27 KHF29 KHF36 KHF38</p>
   166 mm	   166 mm	   238 mm	   310 mm



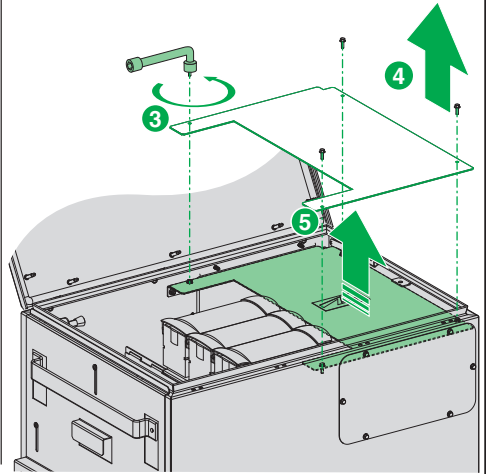
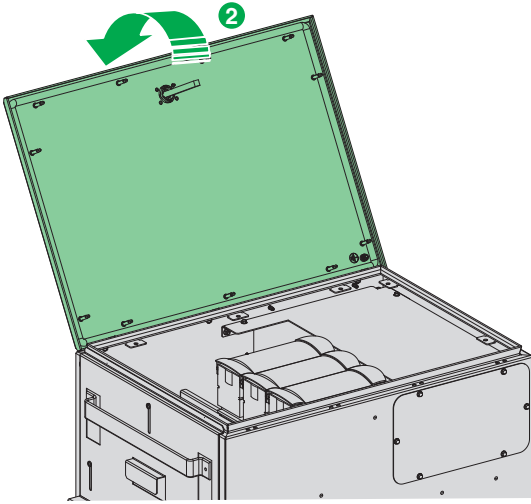
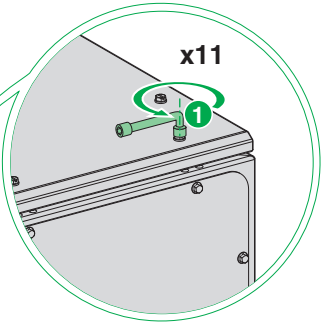
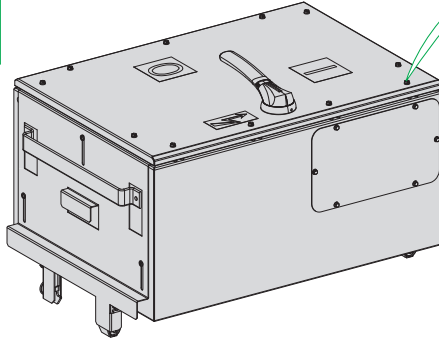
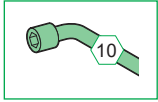

Version PEN  
KHB0630SE5

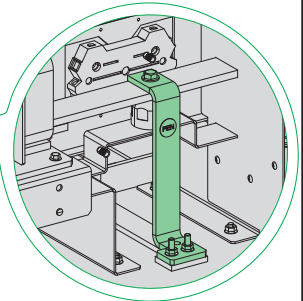
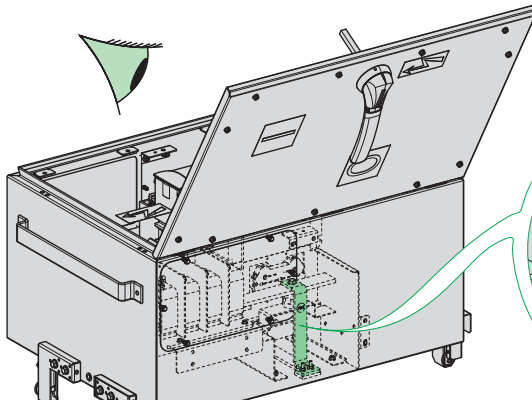

KHF14  
KHF16  
KHF18  
KT●EH●

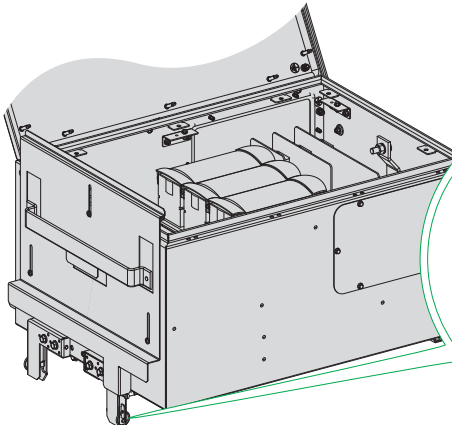
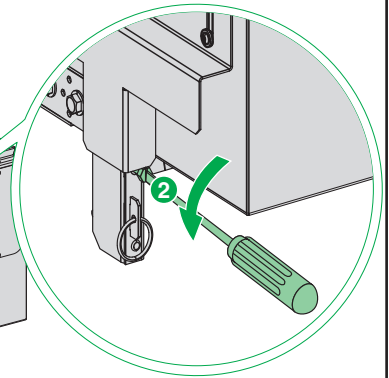
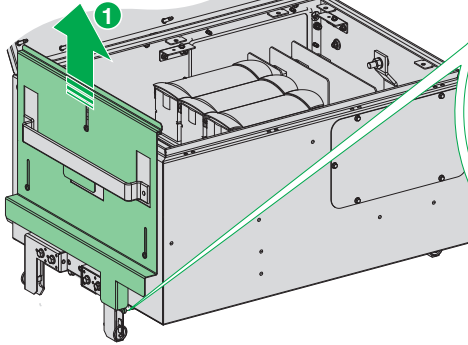
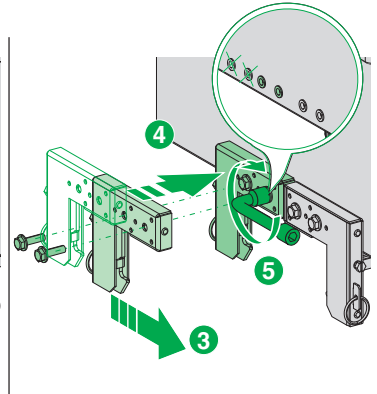
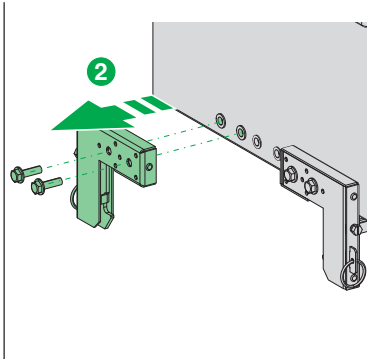
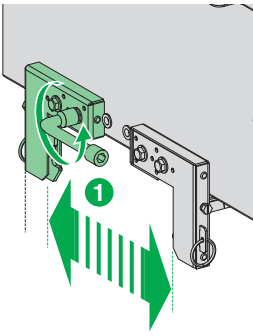

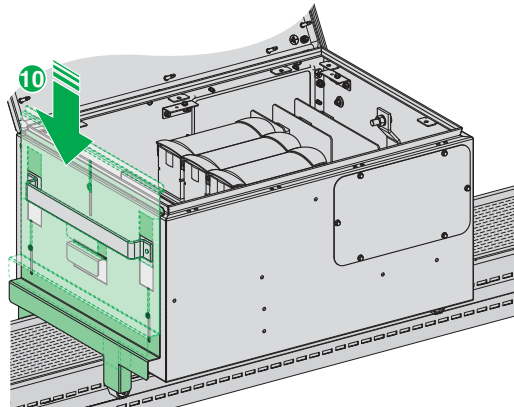
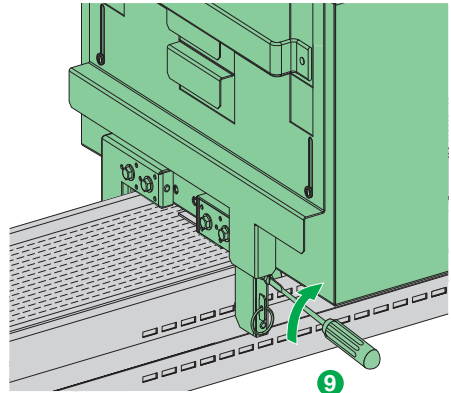
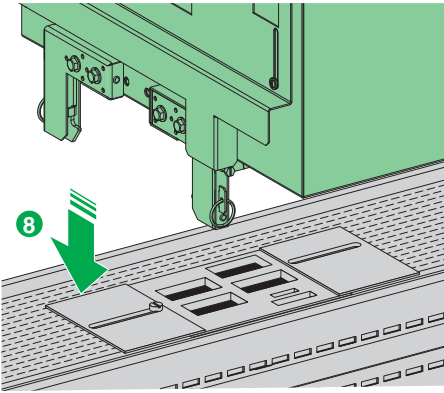
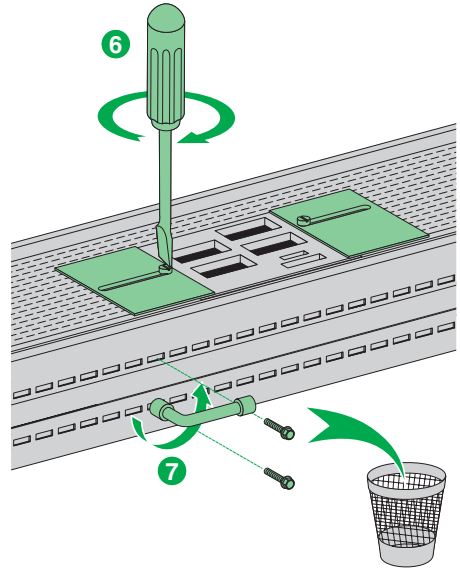
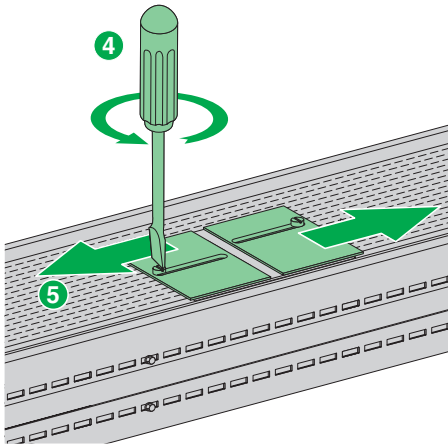

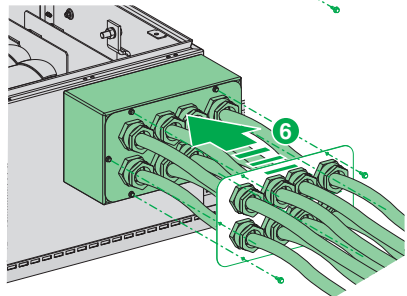
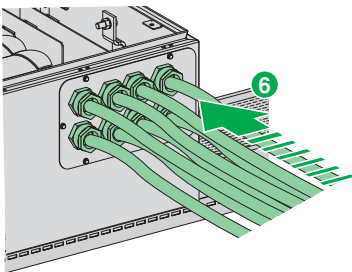
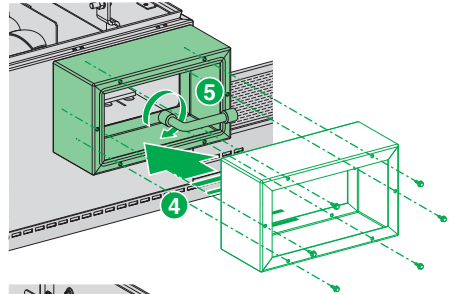
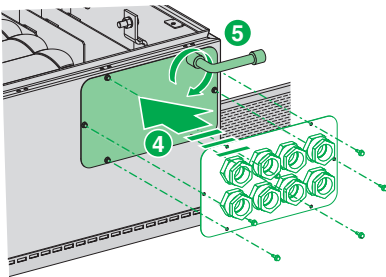
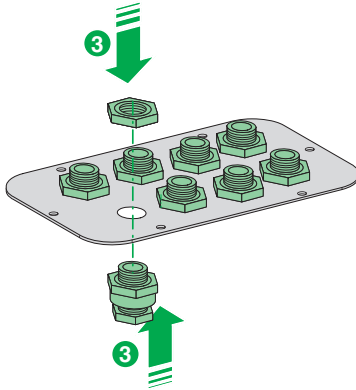
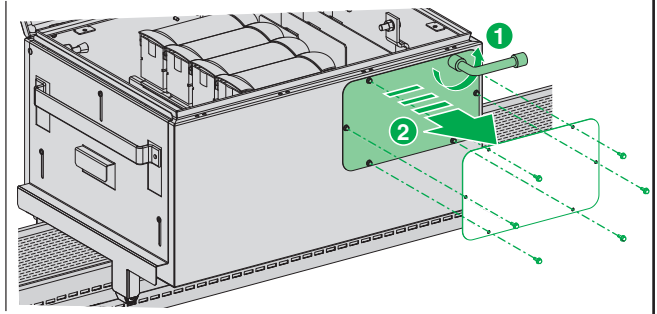
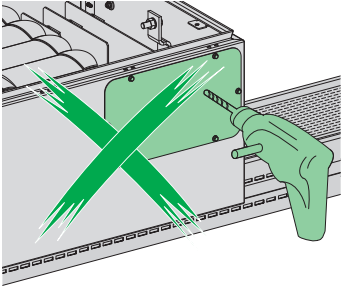

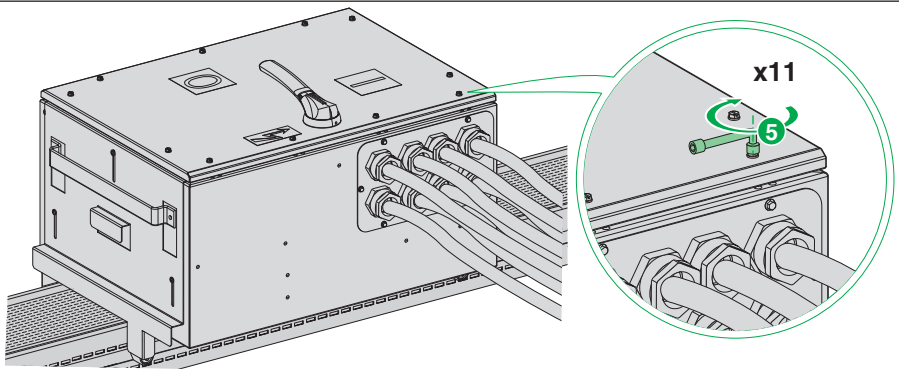
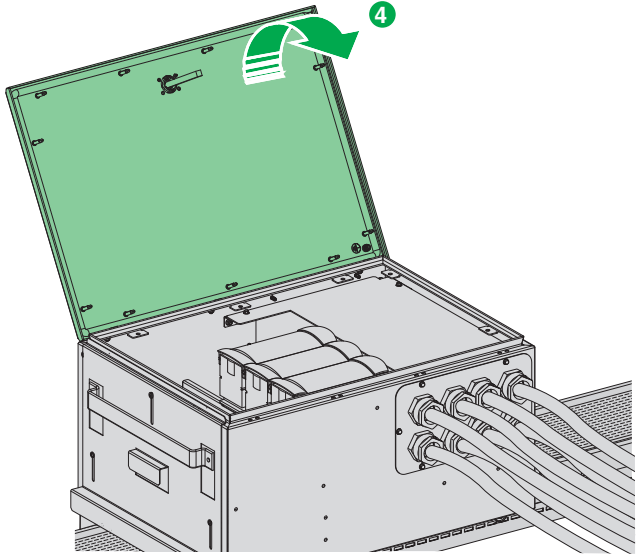
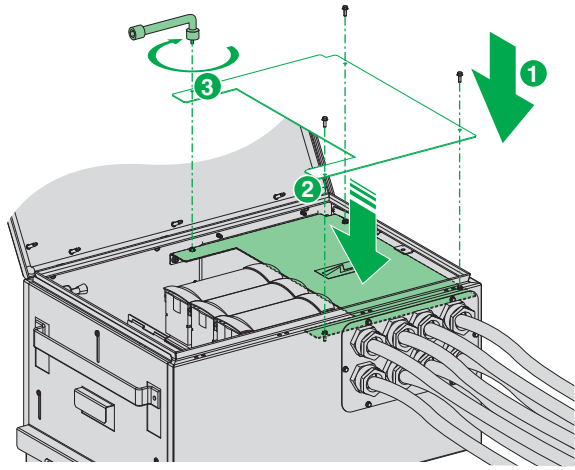

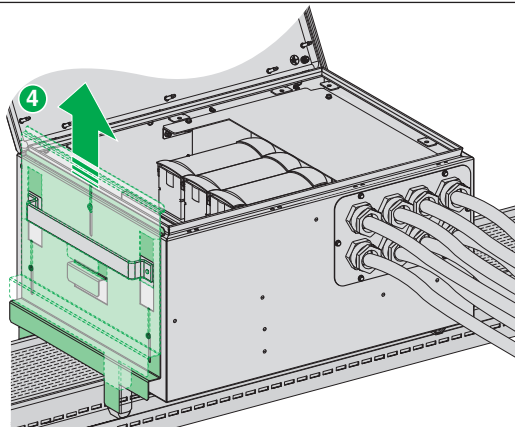
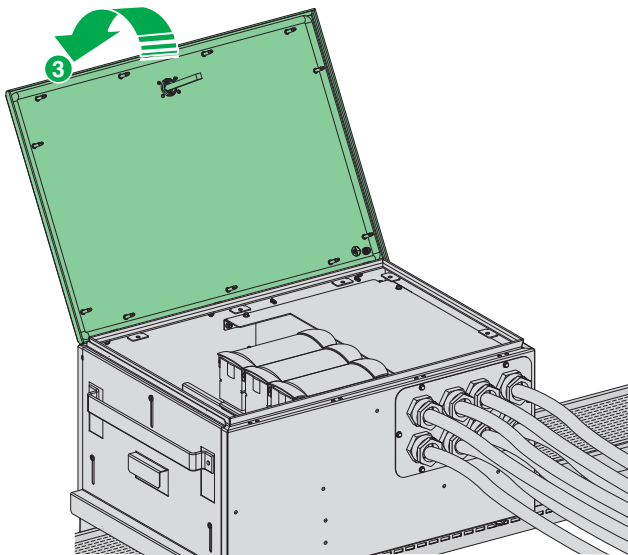
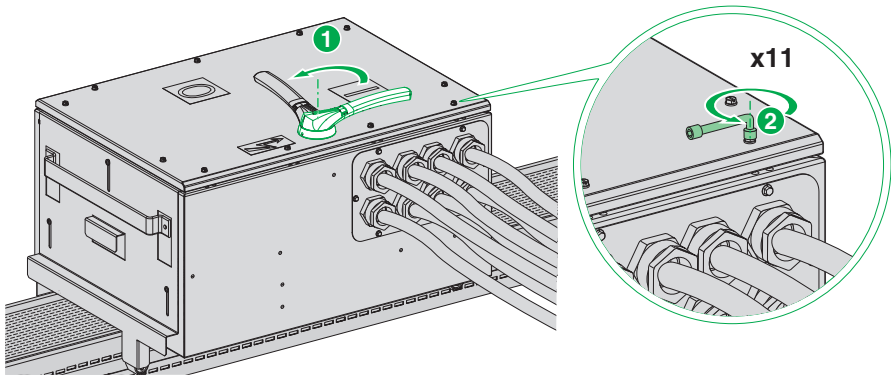

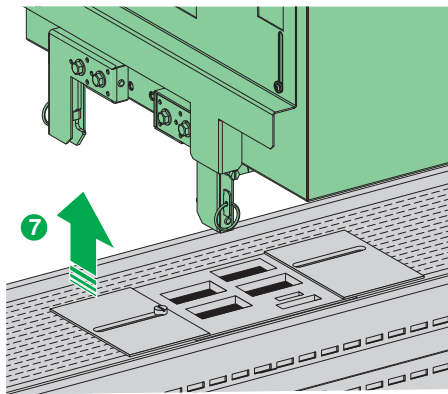
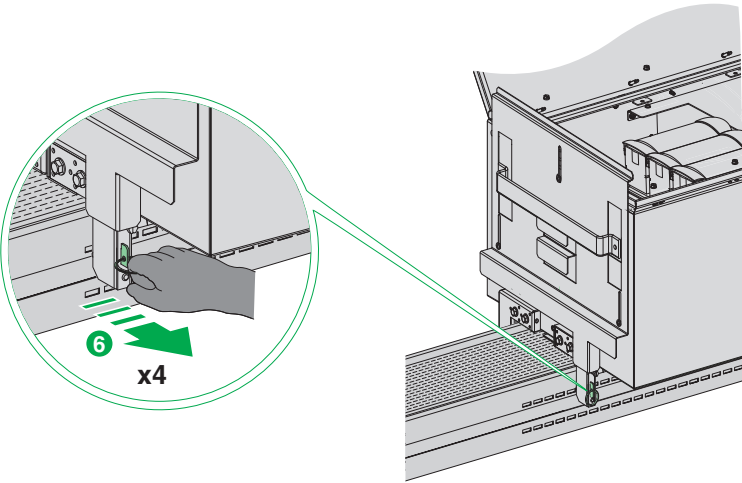
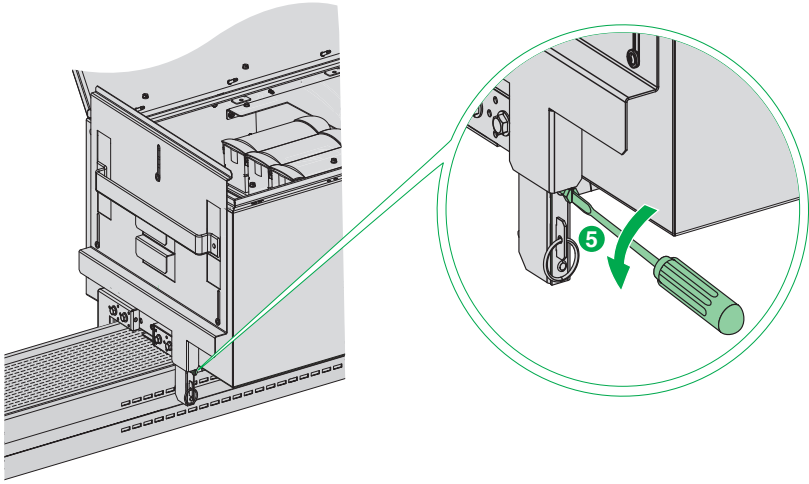

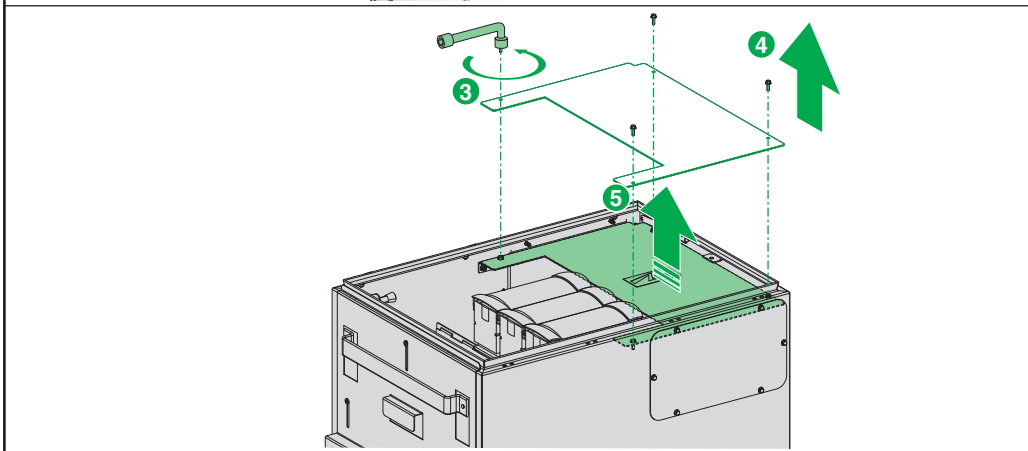
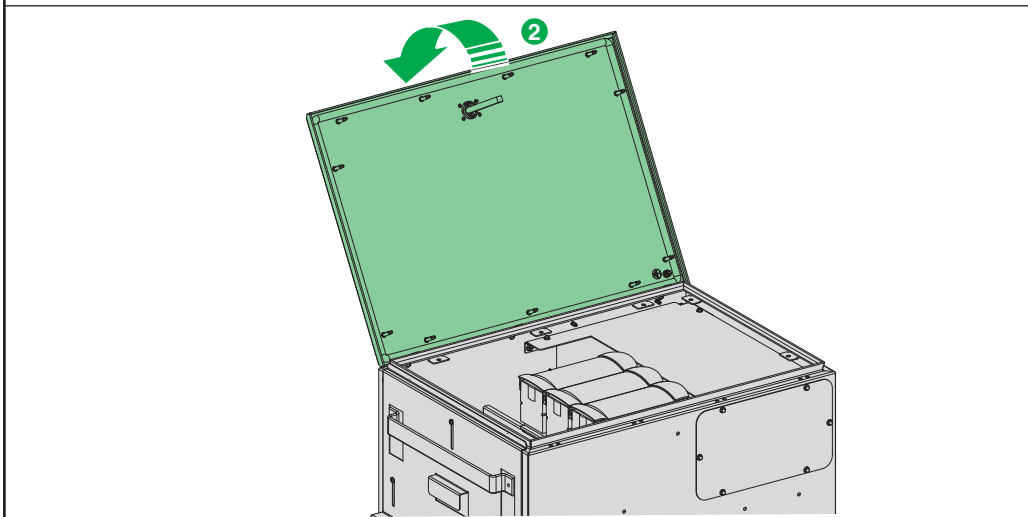
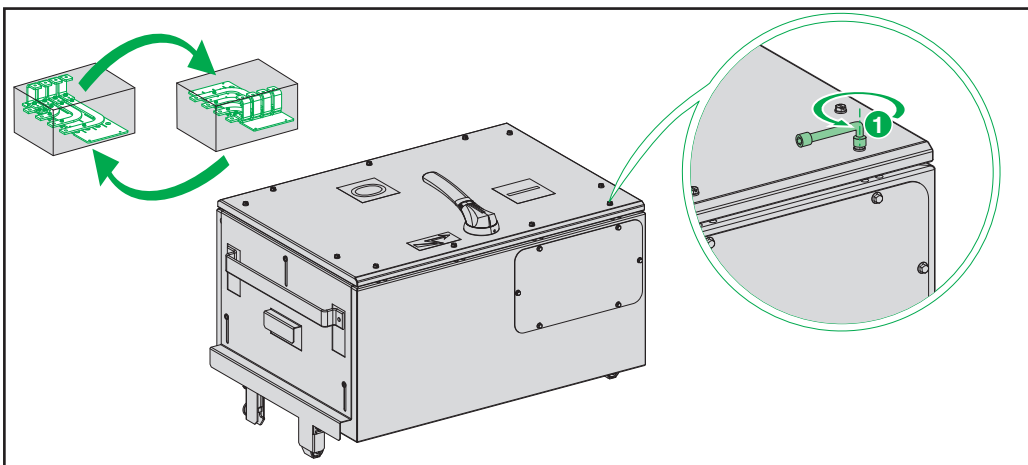



16 x4

50 N.m

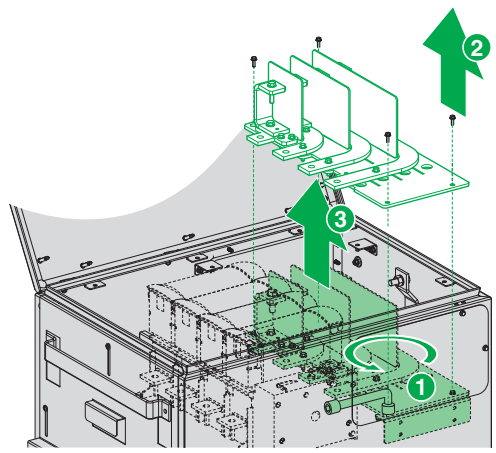
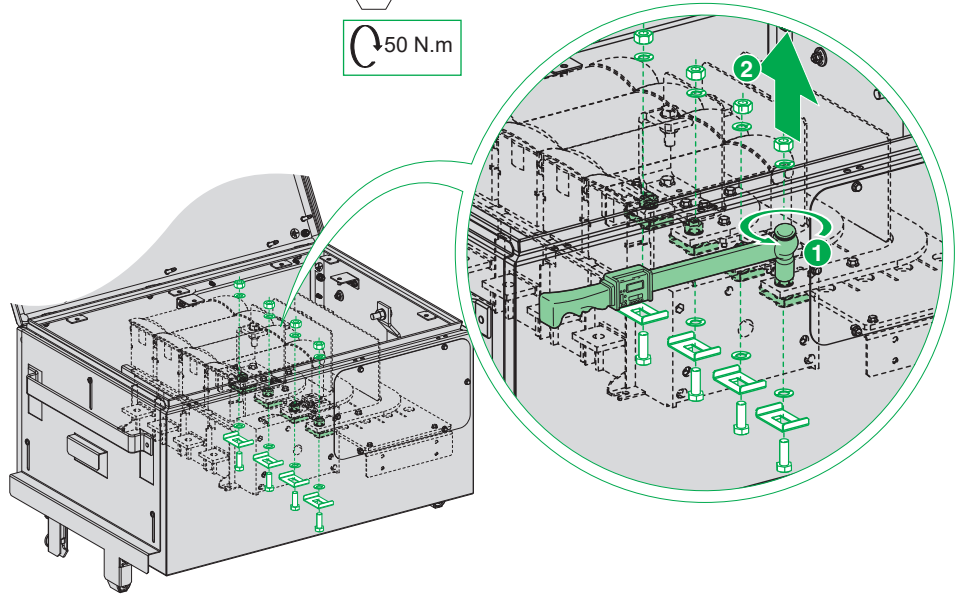

ø13 mm

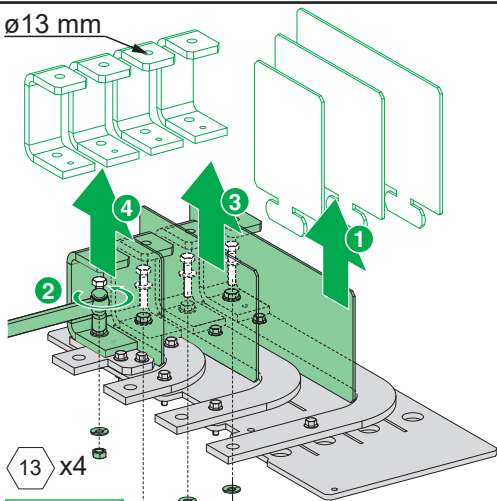

13 x4

28 N.m

6,5 N.m

10 x8

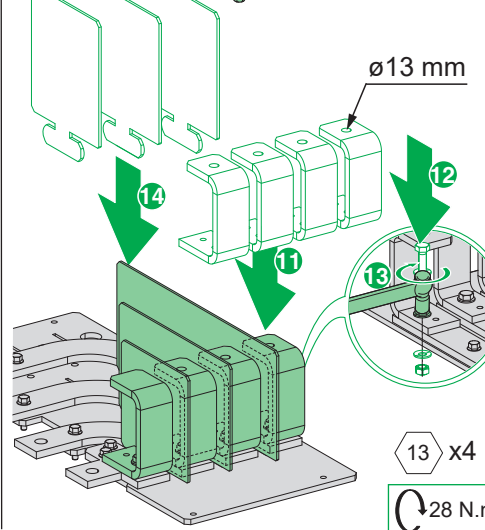
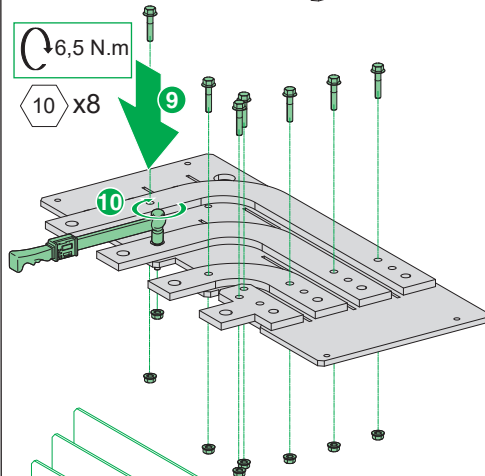
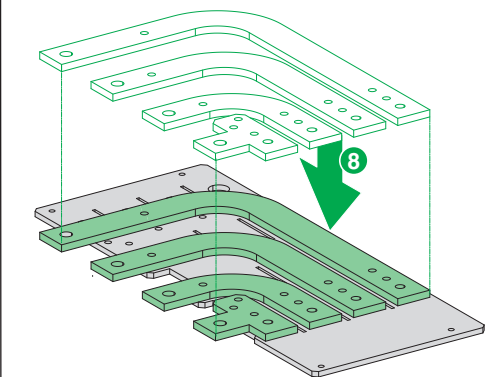
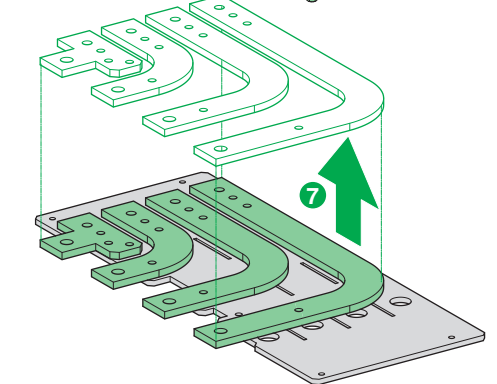
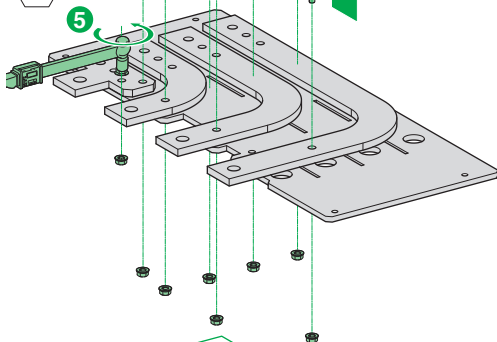

ø13 mm

13 x4

28 N.m

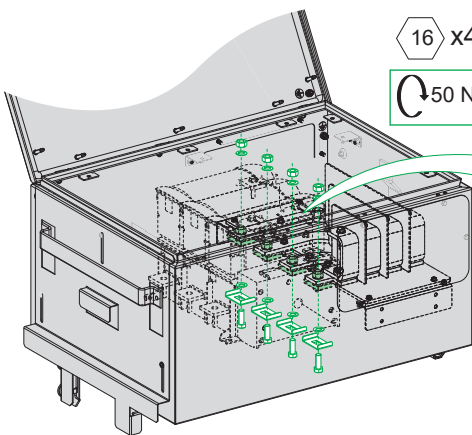
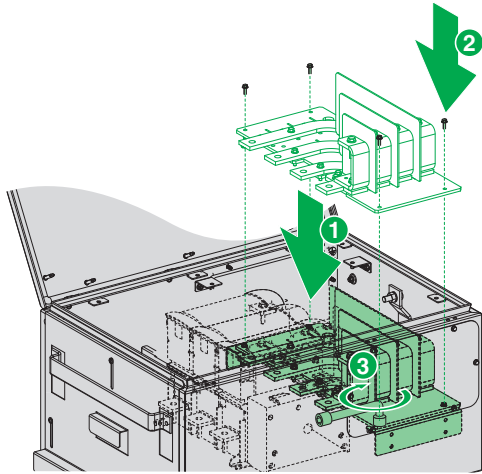

16 x4

50 N.m

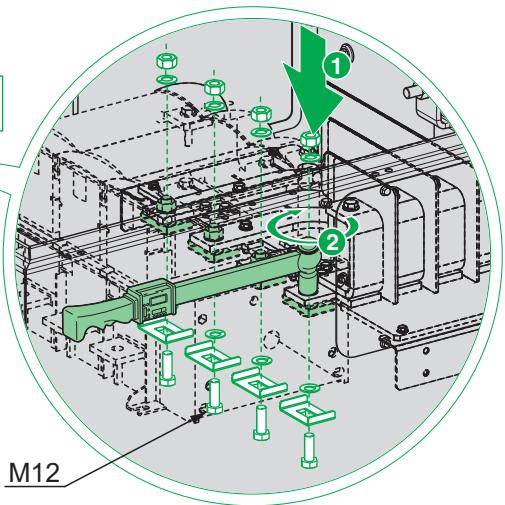

M12

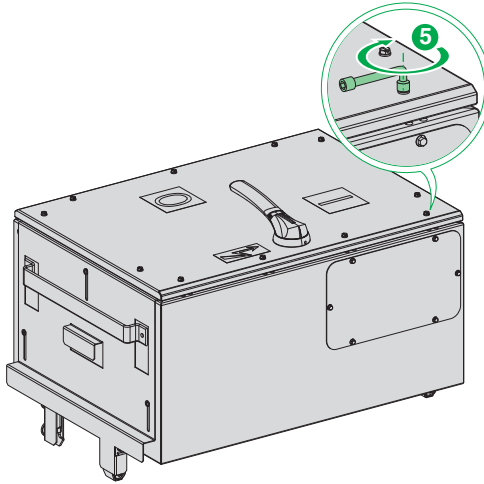
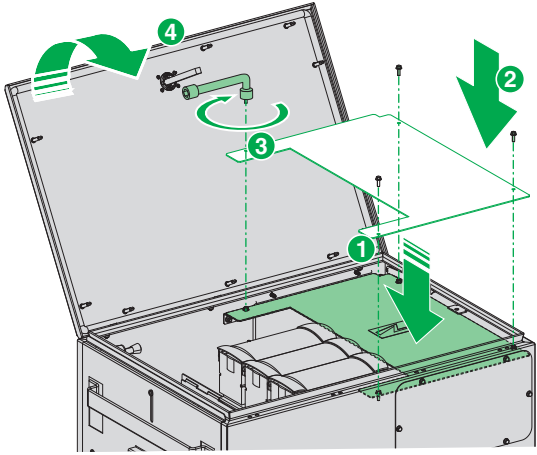

**Schneider Electric Industries SAS**  
 35, rue Joseph Monier  
 CS 30323  
 F - 92506 Rueil Malmaison Cedex  
[www.se.com](http://www.se.com)

**Schneider Electric Limited**  
 Stafford Park 5  
 Telford, TF3 3BL  
 United Kingdom  
[www.se.com/uk](http://www.se.com/uk)



**Уполномоченный поставщик в Республике Казахстан:**  
**ТОО «Шнейдер Электрик»**

Адрес: 050010, РК, г. Алматы, пр. Достык, 38,  
 Бизнес Центр «Кен Дала», 5 этаж, левое крыло.  
 Тел. +7 (727) 3 57 23 57  
 Факс.: +7 (727) 357 24 39



**Қазақстан Республикасында ресми жеткізуші:**  
**ЖШС «Шнейдер Электрик»**

Мекен-жайы: Қазақстан Республикасы, Алматы қ.,  
 Достық даң. ү. 38,  
 «Кен Дала» Бизнес Орталығы, 5-ші қабат.  
 Тел.: +7 (727) 357 23 57  
 Факс.: +7 (727) 357 24 39