



LBV311-XXACVC8MX

LBV301

VIBRATING LEVEL SWITCH

SICK
Sensor Intelligence.



Illustration may differ



Ordering information

Type	Part no.
LBV311-XXACVC8MX	6075219

Other models and accessories → www.sick.com/LBV301

Detailed technical data

Features

Medium	Bulk solids
Measurement	Switch
Probe length	160 mm
Process pressure	-1 bar ... 16 bar
Process temperature	-50 °C ... +150 °C
Fill material density	≥ 0.02 g/cm³

Performance

Accuracy of sensor element	± 10 mm
Reproducibility	≤ 5 mm
Response time	500 ms when covered / 1,000 ms when uncovered
MTBF	4,17*10 ⁶ h

Electronics

Power consumption	< 4.2 mA
Initialization time	< 3 s
VDE protection class 1	✓
Connection type	M20 x 1.5
Output signal	Non-contact switch
Supply voltage	Non-contact switch: 20 V AC/DC ... 253 V DC
Hysteresis	10 mm
Output current	< 400 mA
Inductive load	1 H
Capacitive load	100 nF
Enclosure rating	IP66 / IP67

Mechanics

Process connection	Tri-Clamp 2" (316L, R _a < 0.8 µm)
Housing material	Stainless steel (electropolished), 316L

Sensor material	Stainless steel 316L, 318S
------------------------	----------------------------

Ambient data

Ambient operating temperature	-40 °C ... +70 °C
Ambient temperature, storage	-40 °C ... +80 °C

Classifications

ECLASS 5.0	27273202
ECLASS 5.1.4	27273202
ECLASS 6.0	27273202
ECLASS 6.2	27273202
ECLASS 7.0	27273202
ECLASS 8.0	27273202
ECLASS 8.1	27273202
ECLASS 9.0	27273202
ECLASS 10.0	27273202
ECLASS 11.0	27273202
ECLASS 12.0	27273106
ETIM 5.0	EC002654
ETIM 6.0	EC002654
ETIM 7.0	EC002654
ETIM 8.0	EC002654
UNSPSC 16.0901	41111938

Type code

LBV311 type code

Certification

XX	without
CX	ATEX II 1G, ½ G, 2G Ex ia IIC T6
CK	ATEX II 1G, ½ G, 2G Ex ia IIC T6 + 1D, 1/2D, 2D Ex tD IP66 T
LX	ATEX II ½ G, 2G Ex d IIC T6
LK	ATEX II ½ G, 2G Ex d IIC T6 + 1D, ½ D, 2D Ex tD IP66 T
GX	ATEX II 1D, ½ D, 2D Ex tD IP66 T

Execution / Process temperature

A	Standard / -50 °C ... +150 °C
B	With spacer / -50 °C ... +250 °C
C	Detection of solids in water / -50 °C ... +150 °C

Process connection / Material (see below)

Electronics

C	Contact-free switch 20 ... 253 V AC (DC)
R	Relay (DPDT) 20 ... 72 V DC / 20 ... 253 V AC (3A)
T	Transistor (NPN/PNP) 10 ... 55 V DC
N	NAMUR signal

Housing / Enclosure rating

K	Plastic / IP 66, IP 67
A	Aluminum / IP 66, IP 67
V	Stainless steel (investment casting) 316L / IP 66, IP 67
8	Stainless steel (electropolished) 316L / IP 66, IP 67

Cable entry / Male connector connection

M	M20 x 1.5 / Without
N	½" NPT / Without

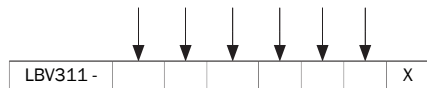

Not all variants of the type code can be combined! Not all available variants are shown.

Process connection / Material

GC	Thread G 1, DIN 3852-A, PN 16 / 316L	EF	Flange DN 50, PN 40, form C, DIN 2501 / 316L
GR	Thread G 1, DIN 3852-A, PN 16 / 316L, Ra < 0.8 µm	4F	Flange DN 65, PN 16, form C, DIN 2501 / 316L
GG	Thread G 1 ½, DIN 3852-A, PN 16 / 316L	No error	Flange DN 80, PN 40, form C, DIN 2501 / 316L
GP	Thread G 1 ½, DIN 3852-A, PN 16 / 316L, Ra < 0.8 µm	ZF	Flange DN 100, PN 6, form C, DIN 2501 / 316L
NC	Thread 1" NPT, ASME B1.20.1, PN 16 / 316L	MF	Flange DN 100, PN 16, form C, DIN 2501 / 316L
NR	Thread 1" NPT, ASME B1.20.1, PN 16 / 316L, Ra < 0.8 µm	OF	Flange DN 100, PN 40, form C, DIN 2501 / 316L
NH	Thread 1 ¼" NPT, ASME B1.20.1, PN 16 / 316L	3F	Flange DN 125, PN 6, form C, DIN 2501 / 316L
NI	Thread 1 ¼" NPT, ASME B1.20.1, PN 16 / 316L, Ra < 0.8 µm	QF	Flange DN 150, PN 16, form C, DIN 2501 / 316L
NG	Thread 1 ½" NPT, ASME B1.20.1, PN 16 / 316L	2F	Flange DN 200, PN 10, form C, DIN 2501 / 316L
NP	Thread 1 ½" NPT, ASME B1.20.1, PN 16 / 316L, Ra < 0.8 µm	EB	Flange DN 50, PN 40, EN 1092-1, form B1 / 316L
CT	Tri-Clamp 1 ½" / 316L, Ra < 0.8 µm	DA	Flange 1 ½" 150 lb RF, ANSI B16.5 / 316L
CV	Tri-Clamp 2" / 316L, Ra < 0.8 µm	EA	Flange 1 ½" 300 lb RF, ANSI B16.5 / 316L
CQ	Tri-Clamp 2 ½" / 316L, Ra < 0.8 µm	HA	Flange 2" 150 lb RF, ANSI B16.5 / 316L
CM	Tri-Clamp 3 ½" / 316L, Ra < 0.8 µm	IA	Flange 2" 300 lb RF, ANSI B16.5 / 316L
RP	Pipe connection DN 40, PN 40, DIN 11851 / 316L, Ra < 0.8 µm	OA	Flange 3" 150 lb RF, ANSI B16.5 / 316L
RF	Pipe connection DN 40, PN 40, DIN 11864-1, form A / 316L, Ra < 0.8 µm	OE	Flange 3" 150 lb FF, ANSI B16.5 / 316L
RH	Pipe connection DN 65, PN 25, DIN 11851 / 316L, Ra < 0.8 µm	PA	Flange 3" 300 lb RF, ANSI B16.5 / 316L
TV	Tuchenhagen Varivent DN 32.1 ½", PN 25 / 316L, Ra < 0.8 µm	PE	Flange 3" 300 lb FF, ANSI B16.5 / 316L
C2	Bundle clamp DN 40, PN 40, DIN 11864-3, form A / 316L, Ra < 0.8 µm	JA	Flange 3 ½" 150 lb RF, ANSI B16.5 / 316L
BF	Flange DN 32, PN 40, form C, DIN 2501 / 316L	SA	Flange 4" 150 lb RF, ANSI B16.5 / 316L
DF	Flange DN 40, PN 40, form C, DIN 2501 / 316L	UA	Flange 4" 300 lb RF, ANSI B16.5 / 316L
AU	Flange DN50 10K RF, JIS / 316L	BU	Flange DN80 10K RF, JIS / 316L
HU	Flange DN65 10K RF, JIS / 316L	CU	Flange DN100 10K RF, JIS / 316L

Dimensional drawing (Dimensions in mm (inch))

LBV311 threaded version G 1 ½ A

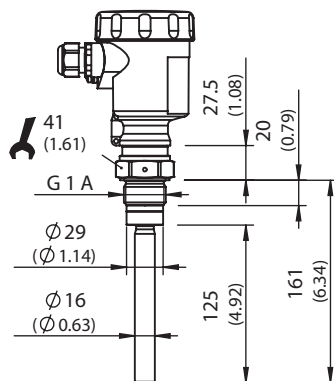

All dimensions in mm (inch)

LBV311 threaded version G 1 A

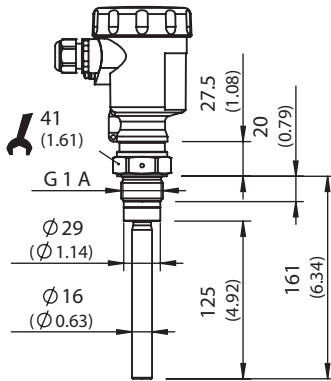

All dimensions in mm (inch)

LBV311 temperature adapter -50 °C ... +250 °C

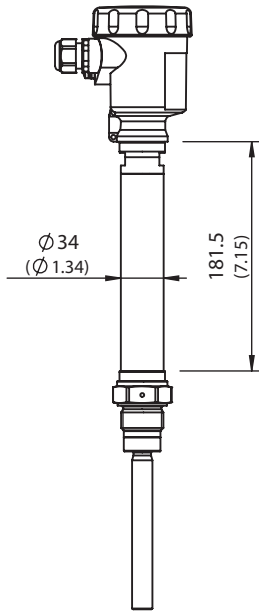

All dimensions in mm (inch)

LBV311 threaded version Tri-Clamp

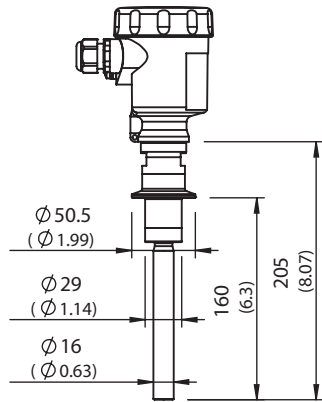

All dimensions in mm (inch)

Connection diagram

Contactless electronic switch connection diagram

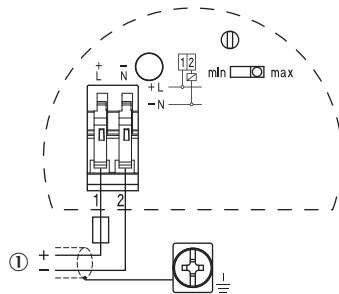

① Shielding

Instruction for installation

Horizontal mounting

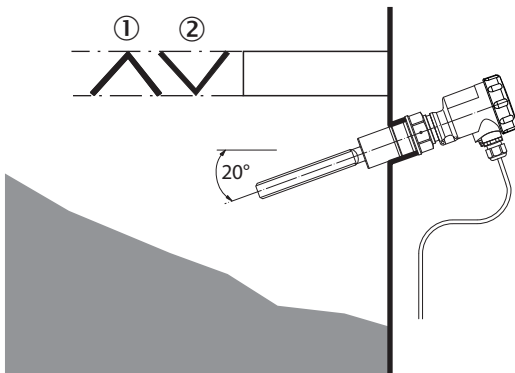

- ① Protective sheet
- ② Concave protective sheet for abrasive solids

Characteristic curve

Ambient temperature - process temperature

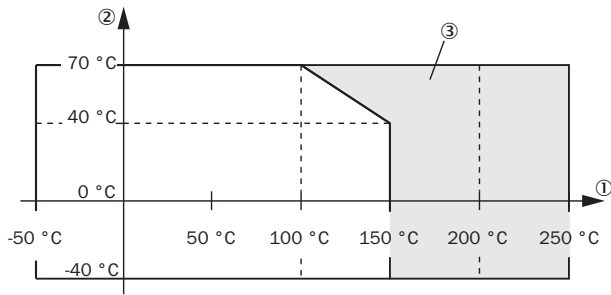

- ① Process temperature in °C (°F)
- ② Ambient temperature in °C (°F)
- ③ Temperature range with temperature adapter

SICK AT A GLANCE

SICK is one of the leading manufacturers of intelligent sensors and sensor solutions for industrial applications. A unique range of products and services creates the perfect basis for controlling processes securely and efficiently, protecting individuals from accidents and preventing damage to the environment.

We have extensive experience in a wide range of industries and understand their processes and requirements. With intelligent sensors, we can deliver exactly what our customers need. In application centers in Europe, Asia and North America, system solutions are tested and optimized in accordance with customer specifications. All this makes us a reliable supplier and development partner.

Comprehensive services complete our offering: SICK LifeTime Services provide support throughout the machine life cycle and ensure safety and productivity.

For us, that is “Sensor Intelligence.”

WORLDWIDE PRESENCE:

Contacts and other locations –www.sick.com