



# FXL1-SPUUSA00

flexLock

SAFETY LOCKING DEVICES

**SICK**  
Sensor Intelligence.



### Ordering information

Locking principle	Switching behavior of the OSSDs	Coding	Escape release	Type	Part no.
Power to lock	Locking monitoring	Uniquely coded	✓	FXL1-SPU-USA00	1122586

The actuator has to be ordered separately. See "Accessories" for further details.

Other models and accessories → [www.sick.com/flexLock](http://www.sick.com/flexLock)

actuator not supplied with delivery



### Detailed technical data

#### Features

<b>Sensor principle</b>	RFID
<b>Locking principle</b>	Power to lock
<b>Coding</b>	Uniquely coded
<b>Locking force <math>F_{max}</math></b>	
Flexible actuator	4,100 N (EN ISO 14119)
Rigid actuator (frontal)	3,630 N (EN ISO 14119)
Rigid actuator (lateral)	3,510 N (EN ISO 14119)
<b>Locking force <math>F_{Zh}</math></b>	
Flexible actuator	3,150 N (EN ISO 14119)
Rigid actuator (frontal)	2,790 N (EN ISO 14119)
Rigid actuator (lateral)	2,700 N (EN ISO 14119)
<b>Actuation force</b>	20 N
<b>Retaining force</b>	30 N
<b>Force against which unlocking is possible</b>	≤ 25 N
<b>Actuation frequency</b>	≤ 1 Hz
<b>Approach speed</b>	≤ 20 m/min

#### Safety-related parameters

<b>Safety integrity level</b>	SIL 3 (IEC 61508)
<b>Category</b>	Category 4 (EN ISO 13849) <sup>1)</sup>
<b>Performance level</b>	PL e (EN ISO 13849) <sup>1)</sup>
<b>PFH<sub>D</sub> (mean probability of a dangerous failure per hour)</b>	$9.55 \times 10^{-9}$ <sup>2)</sup>

<sup>1)</sup> Applies for monitoring of the door position (interlocking monitoring) and locking monitoring.

<sup>2)</sup> At 40 °C and 0 m above sea level.

<b>T<sub>M</sub> (mission time)</b>	20 years (EN ISO 13849)
<b>Type</b>	Type 4 (EN ISO 14119)
<b>Actuator coding level</b>	High coding level (EN ISO 14119)
<b>Safe state in the event of a fault</b>	At least one safety-related semiconductor output (OSSD) is in the OFF state.

<sup>1)</sup> Applies for monitoring of the door position (interlocking monitoring) and locking monitoring.

<sup>2)</sup> At 40 °C and 0 m above sea level.

## Functions

<b>Escape release</b>	✓
<b>Switching behavior of the OSSDs</b>	Locking monitoring
<b>Safe series connection</b>	In control cabinet (with diagnostics) With Flexi Loop (with diagnostics) With T-connector (without diagnostics)

## Interfaces

<b>Connection type</b>	Plug connector, M12, 8-pin
Coupling nut material	Stainless steel
<b>Display elements</b>	LEDs
Diagnostics indicator	✓
Status display	✓

## Electrical data

<b>Protection class</b>	III (IEC 61140)
<b>Contamination rating</b>	3 (IEC 60947-1)
<b>Classification according to cULus</b>	Class 2
<b>Usage category</b>	DC-13 (IEC 60947-5-3)
<b>Rated insulation voltage U<sub>i</sub></b>	32 V
<b>Rated impulse withstand voltage U<sub>imp</sub></b>	1,500 V
<b>Supply voltage V<sub>s</sub></b>	24 V DC (19.2 V DC ... 28.8 V DC)
<b>Power consumption</b>	
Locking device unlocked	65 mA
Locking device locked	125 mA
<b>Peak current</b>	800 mA, 200 ms
<b>Type of output</b>	Self-monitoring semiconductor outputs (OSSDs)
Safety outputs	2 PNP semiconductors, short-circuit protected, cross-circuit monitored
<b>Output current</b>	
Safety outputs	≤ 100 mA
Application diagnostic outputs	≤ 50 mA
<b>Output voltage</b>	U <sub>V</sub> - 2 V DC ... U <sub>V</sub>
<b>Response time</b>	≤ 150 ms <sup>1)</sup>
<b>Release time</b>	≤ 350 ms <sup>1)</sup>
<b>Risk time</b>	150 ms <sup>1)</sup>
<b>Switch-on time</b>	3 s

<sup>1)</sup> In safe series connection: The value increases by 70 ms with each additional switch.

<b>Locking principle</b>	Power to lock
--------------------------	---------------

<sup>1)</sup> In safe series connection: The value increases by 70 ms with each additional switch.

### Mechanical data

<b>Weight</b>	535 g
<b>Material</b>	
Housing	VISTAL®
Ball bracket	Stainless steel
Latch plate of the actuator	Stainless steel
Plug connectors	Stainless steel
<b>Mechanical life</b>	1 x 10 <sup>6</sup> switching cycles

### Ambient data

<b>Enclosure rating</b>	IP65, IP67, IP69K (IEC 60529, IEC 60529, IEC 20653)
<b>Ambient operating temperature</b>	-20 °C ... +55 °C
<b>Storage temperature</b>	-25 °C ... +70 °C
<b>Relative humidity</b>	10 % ... 95 %, at 40 °C (IEC 60068)
<b>Vibration resistance</b>	10 Hz ... 55 Hz, 1 mm (IEC 60068-2-6)
<b>Shock resistance</b>	30 g, 11 ms (EN 60068-2-27)
<b>EMC</b>	EN IEC 61326-3-1, EN IEC 60947-5-2, EN IEC 60947-5-3, EN 300330

### Classifications

<b>ECLASS 5.0</b>	27272603
<b>ECLASS 5.1.4</b>	27272603
<b>ECLASS 6.0</b>	27272603
<b>ECLASS 6.2</b>	27272603
<b>ECLASS 7.0</b>	27272603
<b>ECLASS 8.0</b>	27272603
<b>ECLASS 8.1</b>	27272603
<b>ECLASS 9.0</b>	27272603
<b>ECLASS 10.0</b>	27272603
<b>ECLASS 11.0</b>	27272603
<b>ECLASS 12.0</b>	27272603
<b>ETIM 5.0</b>	EC002593
<b>ETIM 6.0</b>	EC002593
<b>ETIM 7.0</b>	EC002593
<b>ETIM 8.0</b>	EC002593
<b>UNSPSC 16.0901</b>	39122205

**Dimensional drawing** (Dimensions in mm (inch))

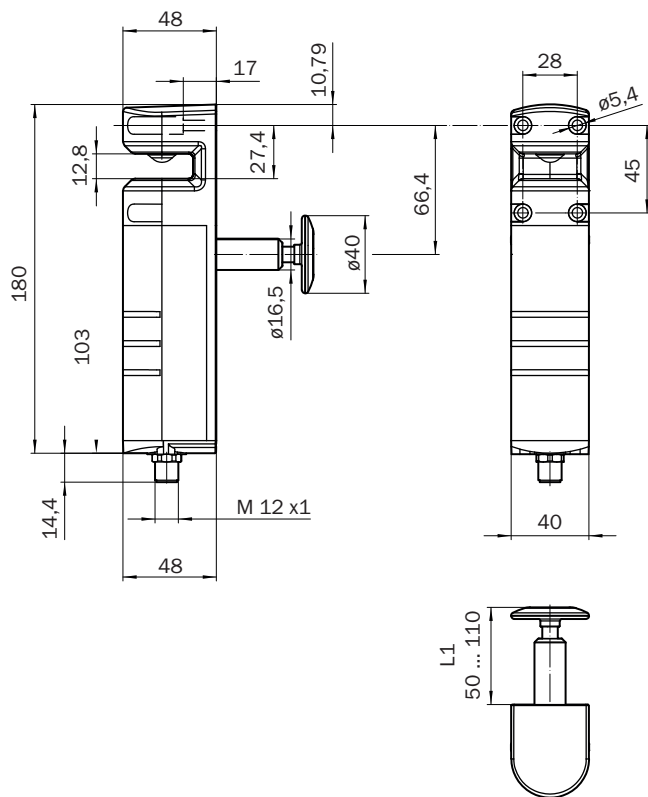

**Series connection**

Series connection with T-piece (without diagnostics)

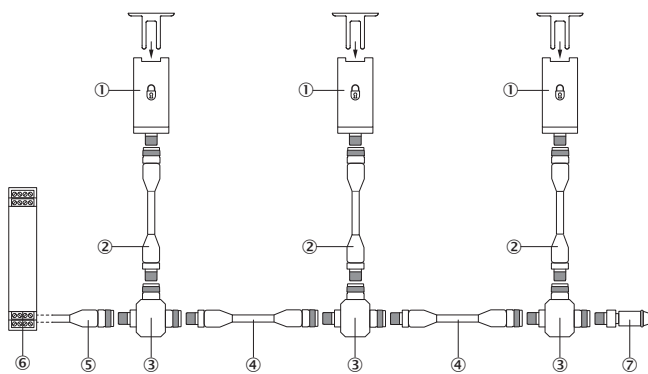

- ① flexLock safety locking device
- ② Connection cable with 8-pin, M12 male connector and 8-pin, M12 female connector (e.g., YF2A18-xxxUA5M2A18)
- ③ T-junctions
- ④ Connection cable with 5-pin, M12 male connector and 5-pin, M12 female connector (e.g., YF2A15-xxxUB5M2A15)
- ⑤ Connecting cable with M12 female connector, 5-pin and flying leads (e.g., YF2A15-xxxVB5XLEAX)
- ⑥ Safe evaluation unit
- ⑦ End plug

Series connection with Flexi Loop (with diagnostics)

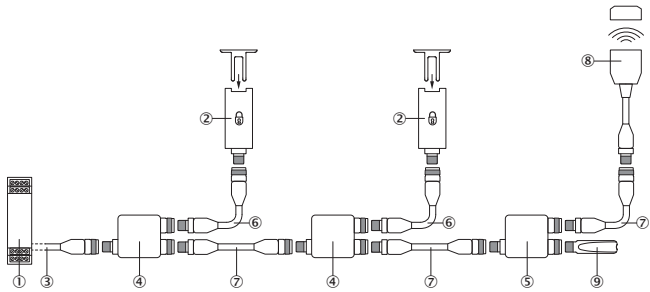

- ① Flexi Compact safety controller
- ② flexLock safety locking device
- ③ Connecting cable with M12 female connector, 5-pin and flying leads (e.g., YF2A15-xxxVB5XLEAX)
- ④ FLN-OSSD1100108 Flexi Loop node
- ⑤ FLN-OSSD1000105 Flexi Loop node
- ⑥ Connection cable with 8-pin, M12 male connector and 8-pin, M12 female connector (e.g., YF2A18-xxxUA5M2A18)
- ⑦ Connection cable with 5-pin, M12 male connector and 5-pin, M12 female connector (e.g., YF2A15-xxxUB5M2A15)
- ⑧ STR1 RFID safety switch (e.g., STR1-SAx0AC5)
- ⑨ FLT-TERM00001 Flexi Loop terminating element

### Connection diagram

Series connection of three flexLock safety locking devices to RLY3-OSSD2 safety relay

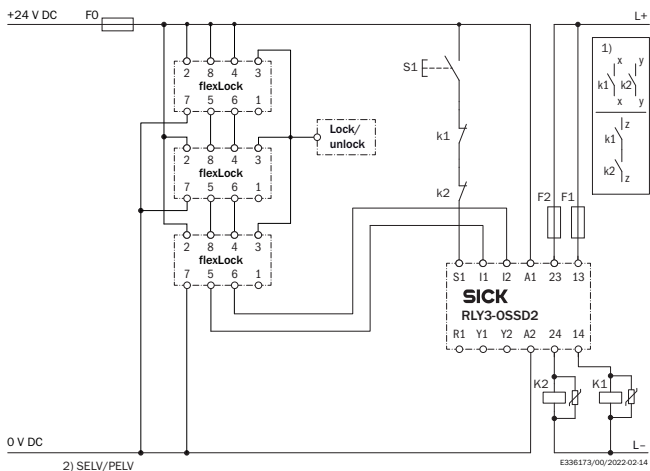

flexLock safety locking device to RLY3-OSSD2 safety relay

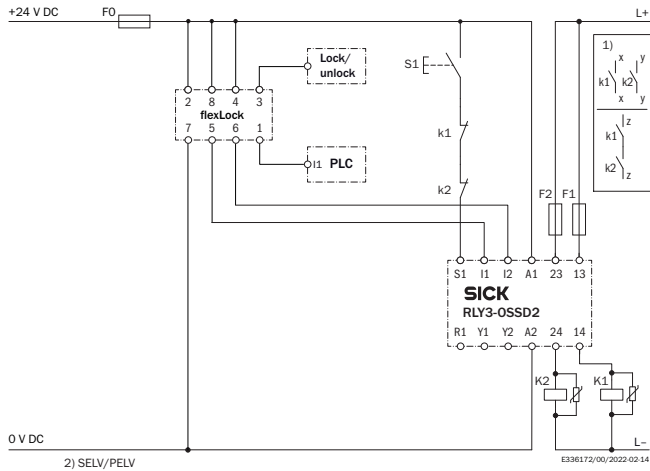

### Pin assignment

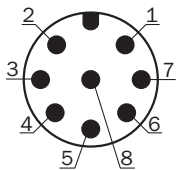



Pin	Designation	Description
1	Out AUX	Application diagnostic output (not safe)
2	+24 V DC	24 V DC voltage supply
3	LOCK	Locking device input
4	In 2	Enable input for OSSD 2*
5	OSSD 1	OSSD 1 output
6	OSSD 2	OSSD 2 output
7	0 V	0 V DC voltage supply
8	In 1	Enable input for OSSD 1*

\* When used as an individual safety locking device or as the first safety locking device in a safe series connection, apply 24 V DC.

### Recommended accessories

Other models and accessories → [www.sick.com/flexLock](http://www.sick.com/flexLock)

	Brief description	Type	Part no.
<b>Actuators</b>			
	Flexible actuator, can be inserted into the locking device from the front	FXL1-AF1	1101326

	Brief description	Type	Part no.
	Rigid actuator, can be inserted into the locking device from the front or side	FXL1-AR1	1101327



## SICK AT A GLANCE

SICK is one of the leading manufacturers of intelligent sensors and sensor solutions for industrial applications. A unique range of products and services creates the perfect basis for controlling processes securely and efficiently, protecting individuals from accidents and preventing damage to the environment.

We have extensive experience in a wide range of industries and understand their processes and requirements. With intelligent sensors, we can deliver exactly what our customers need. In application centers in Europe, Asia and North America, system solutions are tested and optimized in accordance with customer specifications. All this makes us a reliable supplier and development partner.

Comprehensive services complete our offering: SICK LifeTime Services provide support throughout the machine life cycle and ensure safety and productivity.

For us, that is “Sensor Intelligence.”

## WORLDWIDE PRESENCE:

Contacts and other locations –[www.sick.com](http://www.sick.com)