

THIS COPY IS PROVIDED ON A RESTRICTED BASIS AND IS NOT TO BE USED IN ANY WAY DETRIMENTAL TO THE INTERESTS OF PANDUIT CORP.

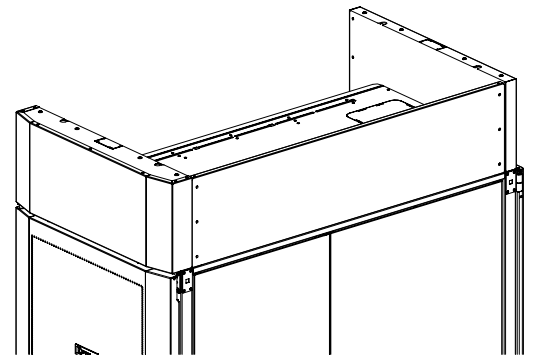

ASSEMBLED VIEW
CABINET NOT INCLUDED

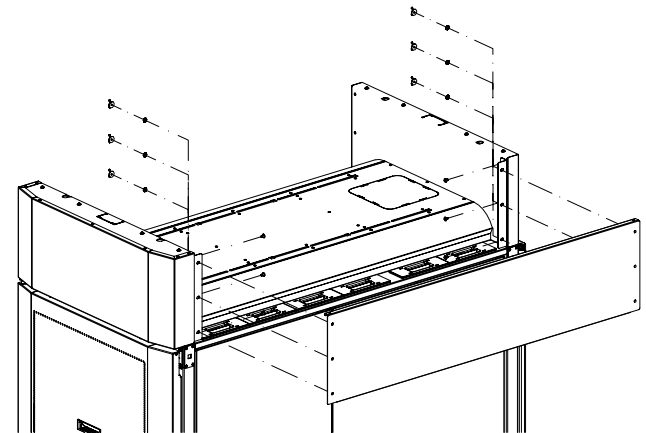

APPLICATION VIEW
CABINET NOT INCLUDED

PANDUIT PART NO.	WEIGHT
SN1070CREC	5.4 LBS/EACH 2.45 Kg/EACH

1. VISIT OUR ON-LINE CATALOG AT WWW.PANDUIT.COM FOR A LIST OF CURRENT PARTS APPLICABLE FOR USE WITH THIS PRODUCT.
2. PRIMARY DIMENSIONS ARE METRIC (mm). DIMENSIONS IN PARENTHESES ARE IN INCHES (IN).
3. PARTS SUPPLIED:
 - 1- 1070 END OF ROW PANEL
 - 2- END OF ROW PANEL "L" BRACKET
 - 1- HARDWARE KIT
 - 1- INSTRUCTION SHEET
4. FULLY BONDED STRUCTURE WHEN ASSEMBLED PER INSTRUCTIONS.
5. COMPATIBLE WITH 1070mm DEEP NET-ACCESS N-TYPE AND S-TYPE CABINETS.
6. PART NUMBER SHOWN AS BLACK. ADD SUFFIX "W" FOR WHITE. "G" FOR GRAY.

REV	DATE	BY	CHK	APR	DESCRIPTION	ECN
00A	3-30-15	PBS	RAMA	TCN	RELEASED TO PRODUCTION	V09000II

TITLE					
(SN1070CREC) NET-ACCESS N-TYPE AND S-TYPE CABINETS TOP OF CABINET CABLE MANAGER - END OF ROW PANEL					
CUSTOMER DRAWING					
ITEM REVISION NAME			09V094PC/00		
DATASET FILE NAME			09V094PC_DC/00A		
			MATERIAL:		
			N/A		
			DRAWING NUMBER:		
			09V094PC - DC		
				THIRD ANGLE PROJECTION	
DRAWN BY	DATE	CHK	SCALE		
PBS	3-30-15	RAMA	NONE	SHT 1 OF 2	
				SIZE	A

THIS COPY IS PROVIDED ON A RESTRICTED BASIS AND IS NOT TO BE USED IN ANY WAY DETRIMENTAL TO THE INTERESTS OF PANDUIT CORP.

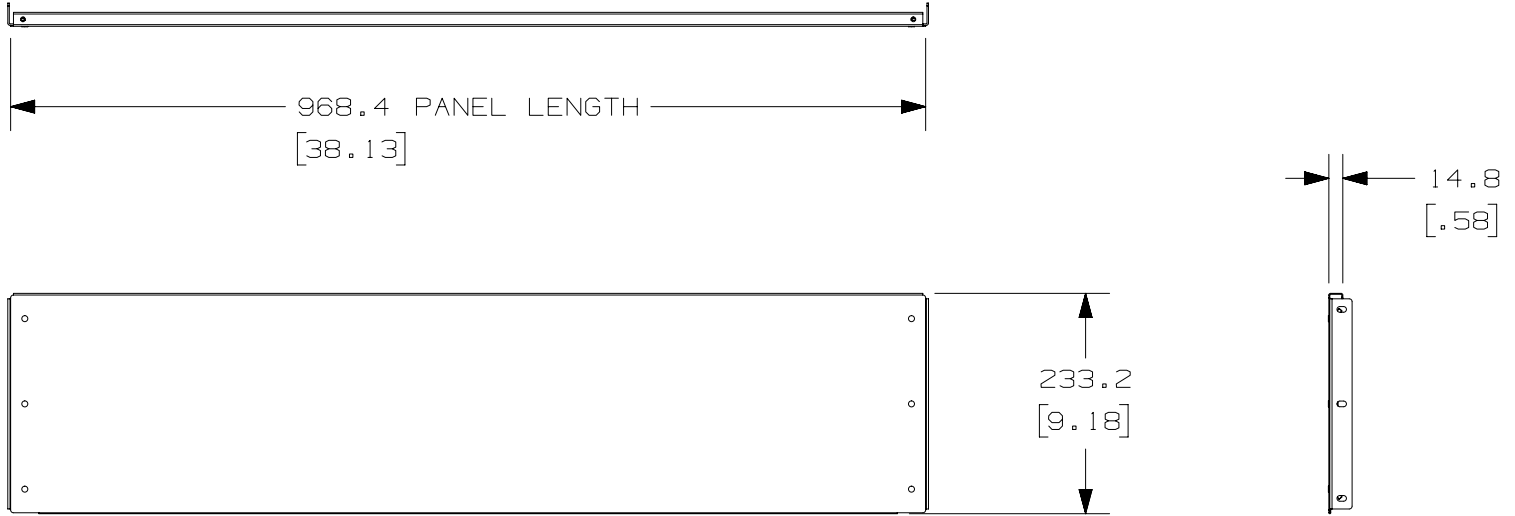

00A	3-30-15	PBS	RAMA	TCN	RELEASED TO PRODUCTION			V09000II	
REV	DATE	BY	CHK	APR	DESCRIPTION			ECN	

TITLE (SN1070CREC) NET-ACCESS N-TYPE AND S-TYPE CABINETS TOP OF CABINET CABLE MANAGER - END OF ROW PANEL		CUSTOMER DRAWING	
ITEM REVISION NAME 09V094PC/00		PANDUIT	
DATASET FILE NAME 09V094PC_DC/00A			
MATERIAL: N/A		DRAWING NUMBER: 09V094PC-DC	
THIRD ANGLE PROJECTION			
DRAWN BY PBS	DATE 3-30-15	CHK RAMA	SCALE NONE
SHT 2 OF 2			SIZE A

D110100DA/16