

## Integral Grommet (New Installations)

#### Parts List:

- Outer ring (A) and fabric\* (B) grommet, with hook and loop seal along the edges (C and D)
- Hook and loop cinch tie (E)
- Flexible gasket (F)
- Self-tapping screws (not shown)

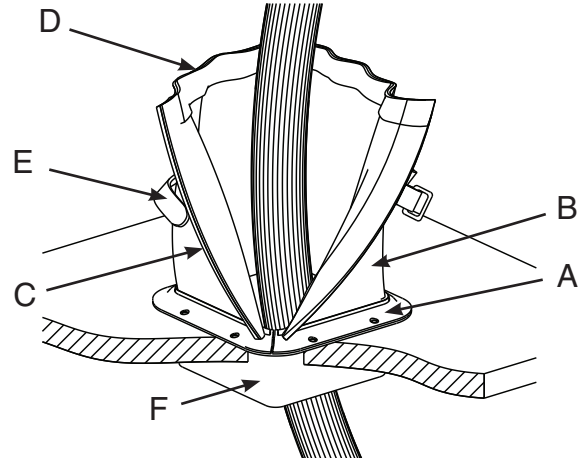

1. Check package with parts list (above) to ensure that all parts of the Cool Boot Raised Floor Air Sealing Grommet are present.
2. Mark outline of cutout space on raised floor tile.\*\*
  - a. Use template found in the packaging of the grommet; or use chart (below) to determine cutout space required according to part number.



Part Number	Required Hole Cutout
RFG6X8Y	4.5" x 6.5"
RFG8X8Y	6.5" x 6.5"
RFG10X8Y	8.5" x 6.5"
RFG12X8Y	10.5" x 6.5"
RFG12X4Y	10.5" x 2.5"
RFG3DY	3" Diameter
RFG5DY	5" Diameter

3. Cut space in tile, in accordance with raised floor manufacturer's specifications.\*\*\*

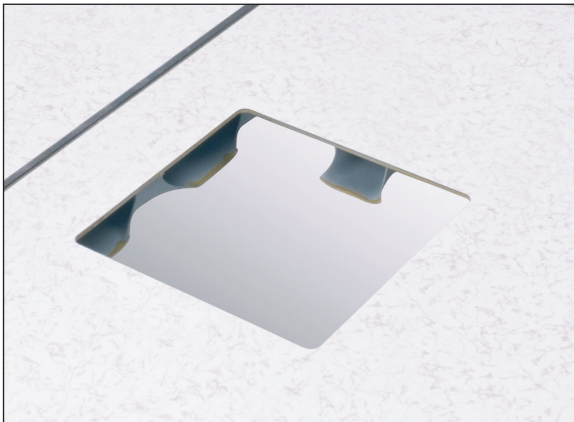

4. Place flexible gasket (F) in tile cutout space. This prevents sharp edges of raised floor from abrading cables that pass through the space.



5. Place outer ring (A) and fabric (B) grommet over gasket (F), and secure outer ring<sup>†</sup> (A) to raised floor using the self-tapping screws that are provided. This ensures a pathway to ground to prevent buildup of electrostatic charge. Note: A 3/32" pilot hole is recommended for concrete filled panels.



6. Pass cable bundles through the grommet, and utilize one of two closure methods:
- For one bundle, use hook and loop cinch tie (E) to gather fabric (B) around cables.
  - For two or more bundles, use hook and loop (D) along top of grommet to seal around cables.



Notes:

\*Fabric material is fire-retardant but not plenum rated, and therefore should be positioned above-floor for maximum performance.

\*\*Installers must comply with appropriate safety procedures when working in a raised floor environment. Use of personal protective equipment such as safety glasses, face shields, respirator, hand protection, and safety footwear are recommended.

\*\*\*Installers must comply with raised floor manufacturer's specifications when cutting or otherwise modifying raised floor products. Specifications include raised floor strength de-rating and/or additional underfloor supports required due to cutout spaces in floor tiles.

†To install or remove product, do not flex outer ring more than necessary to accommodate cable bundle.

For Instructions in Local Languages  
and Technical Support:

[http://www.panduit.com/resources/install\\_maintain.asp](http://www.panduit.com/resources/install_maintain.asp)

**PANDUIT**  
www.panduit.com

E-mail:  
techsupport@panduit.com

Phone:  
866-405-6654