

THIS COPY IS PROVIDED ON A RESTRICTED BASIS AND IS NOT TO BE USED IN ANY WAY DETRIMENTAL TO THE INTERESTS OF PANDUIT CORP.

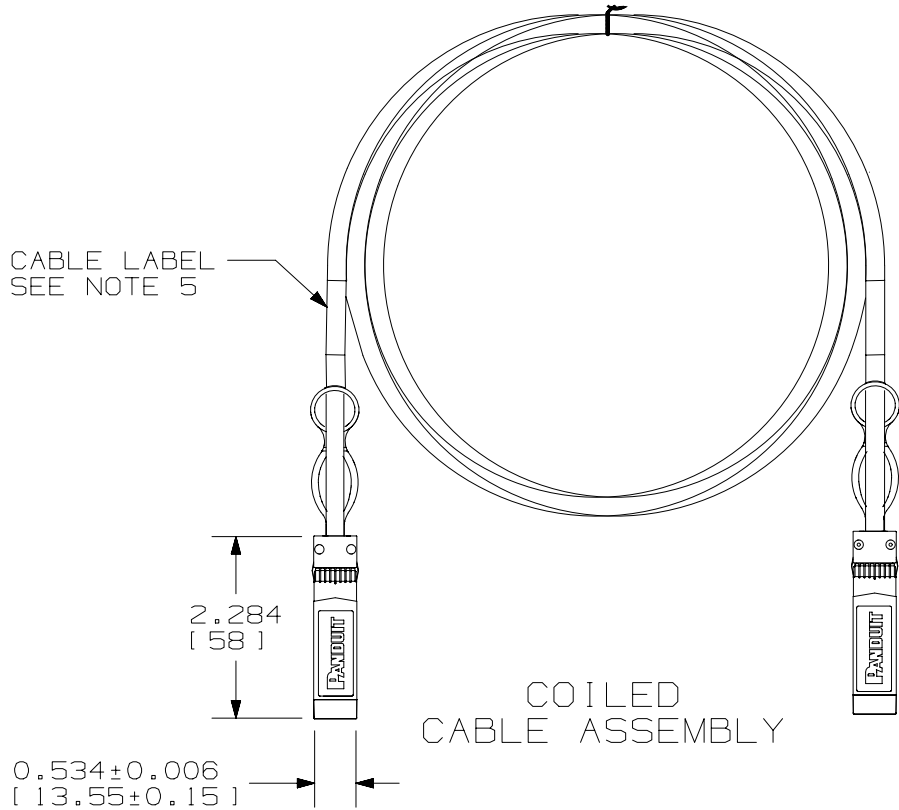

NOTES:

1. SEE CURRENT CATALOG TO INDICATE PACKAGE QUANTITY.
2. SEE CATALOG FOR COMPLETE LIST OF PARTS APPLICABLE FOR USE WITH THIS PART.
3. PRODUCT DESCRIPTION:
 - A. 1 LANE, 25 Gbps/LANE
 - B. STANDARD SFP CONNECTOR
 - C. CL2 RATED JACKET
 - D. JACKET COLOR: BLACK (BL), WHITE (WH), BLUE (BU), RED (RD)
4. MATES WITH SFP SFF-8432 INTERFACE
5. CABLE LABEL CONTAINS PRODUCT DESCRIPTION, PART NUMBER, LENGTH AND WIRE GAUGE, AND MANUFACTURING SERIAL NUMBER.

TABLE 1
CABLE ASSEMBLY

PANDUIT P/N	LENGTH (mm)	xx AWG
PSF2PZA1M**	1000±10	30
PSF2PZA1.5M**	1500±15	30
PSF2PZA2M**	2000±20	30
PSF2PZA2.5M**	2500±25	30
PSF2PZA3M**	3000±30	30
PSF2PZC3.5M**	2500±35	26
PSF2PZC4M**	4000±40	26
PSF2PZC5M**	5000±50	26

**=SEE NOTE 3.D

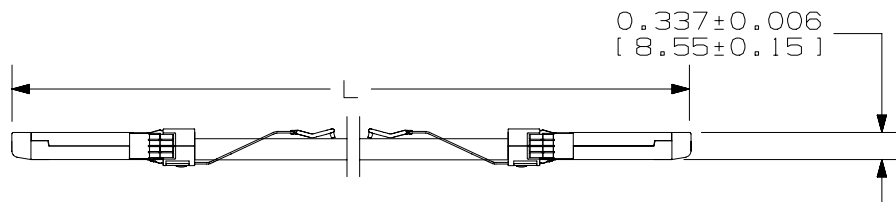

PART NUMBER SEE TABLE 1		PRODUCT SPEC/PKG SPEC N/A	
I.I. NUMBER N/A		WORK INSTRUCTION N/A	
TITLE SFP28 PASSIVE CABLE ASSEMBLY			
CUSTOMER DRAWING			
ITEM REVISION NAME 00275EBA/01		PANDUIT	
DATASET FILE NAME 00275EBA_DC/01A			
UNLESS OTHERWISE SPECIFIED, DIMENSIONAL TOLERANCES ARE: IN [mm]		MATERIAL:	
.x ± .1 [2.54] .xxx ± .005 [.127]		DRAWING NUMBER: 00275EBA-DC	
.xx ± .01 [.25] ANGLES ± 5 °			
THIRD ANGLE PROJECTION			
DRAWN BY BJN	DATE 6-17-20	CHK MATO	SCALE NONE
SHT 1 OF 2		A	

REV	DATE	BY	CHK	APR	DESCRIPTION	ECN
01A	6-12-20	BJN	MATO	DDH	RELEASED TO PRODUCTION	03075-216

D10100DA/14

THIS COPY IS PROVIDED ON A RESTRICTED BASIS AND IS NOT TO BE USED IN ANY WAY DETRIMENTAL TO THE INTERESTS OF PANDUIT CORP.

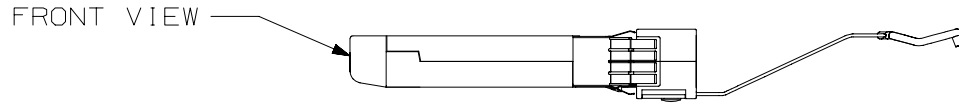
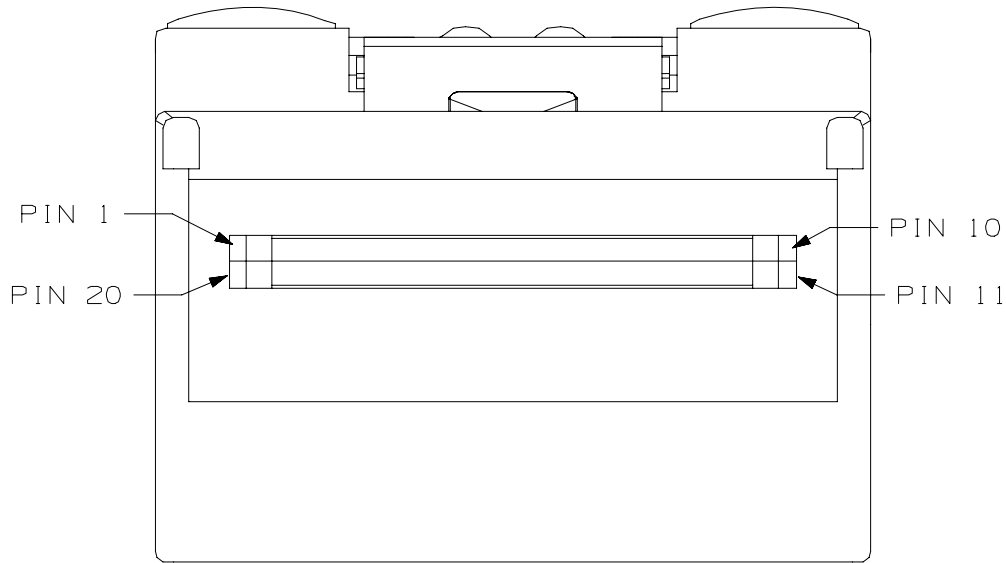

TABLE 2
PINOUT DIAGRAM

BOTTOM SIDE		TOP SIDE	
POS #	SIGNAL	POS #	SIGNAL
1	VEET*	11	VEER*
2	TX_FAULT**	12	RD-
3	TX_DISABLE**	13	RD+
4	SDA	14	VEER*
5	SCL	15	VCCR
6	MOD_ABS	16	VCCT
7	RS0	17	VEET*
8	RX_LOS**	18	TD+
9	RS1	19	TD-
10	VEER*	20	VEET*

* VEE PINS CONNECT FIRST UPON PLUGGING IN.
 ** TX_FAULT, TX_DISABLE, AND RX_LOS ARE DEFINED IN SFF-8432, BUT ARE NOT USED IN PASSIVE DIRECT ATTACH COPPER CABLES.



FRONT VIEW
SEE TABLE 2

PART NUMBER	SEE TABLE 1	PRODUCT SPEC/PKG SPEC	N/A
I.I. NUMBER	N/A	WORK INSTRUCTION	N/A

TITLE	SFP28 PASSIVE CABLE ASSEMBLY
	CUSTOMER DRAWING

ITEM REVISION NAME	00275EBA/01	PANDUIT
DATASET FILE NAME	00275EBA_DC/01A	

UNLESS OTHERWISE SPECIFIED, DIMENSIONAL TOLERANCES ARE: IN (mm)		MATERIAL:
.x ± .1 (2.54)	.xxx ± .005 (.127)	DRAWING NUMBER: 00275EBA-DC
.xx ± .01 (.25)	ANGLES ± 5°	
THIRD ANGLE PROJECTION		

01A	6-17-20	BJN	MATO	DDH	SEE SHEET 1 FOR REVISION HISTORY	00275EBA-DC
-----	---------	-----	------	-----	----------------------------------	-------------

REV	DATE	BY	CHK	APR	DESCRIPTION	ECN	DRAWN BY	DATE	CHK	SCALE	SHT 2 OF 2	SIZE
							BJN	6-17-20	MATO	NONE		A

D101000DA/14

2

1

2

1