



**(en) Electric current! Danger to life!**

Only skilled or instructed persons may carry out the following operations.

**(de)**

**Lebensgefahr durch elektrischen Strom!**

Nur Elektrofachkräfte und elektrotechnisch unterwiesene Personen dürfen die im Folgenden beschriebenen Arbeiten ausführen.

**(fr)**

**Tension électrique dangereuse !**

Seules les personnes qualifiées et averties doivent exécuter les travaux ci-après.

**(es)**

**¡Corriente eléctrica! ¡Peligro de muerte!**

El trabajo a continuación descrito debe ser realizado por personas cualificadas y advertidas.

**(it)**

**Tensione elettrica: Pericolo di morte!**

Solo persone abilitate e qualificate possono eseguire le operazioni di seguito riportate.

**(zh)**

**触电危险!**

只允许专业人员和受过专业训练的人员进行下列工作。

**(ru)**

**Электрический ток! Опасно для жизни!**

Только специалисты или проинструктированные лица могут выполнять следующие операции.

**(nl)**

**Levensgevaar door elektrische stroom!**

Uitsluitend deskundigen in elektriciteit en elektrotechnisch geïnstrueerde personen is het toegestaan, de navolgend beschreven werkzaamheden uit te voeren.

**(da)**

**Livsfare på grund af elektrisk strøm!**

Kun uddannede el-installatører og personer der er instruerede i elektrotekniske arbejdsopgaver, må udføre de nedenfor anførte arbejder.

**(el)**

**Προσοχή, κίνδυνος ηλεκτροπληξίας!**

Οι εργασίες που αναφέρονται στη συνέχεια θα πρέπει να εκτελούνται μόνο από ηλεκτρολόγους και ηλεκτροτεχνίτες.

**(pt)**

**Perigo de vida devido a corrente eléctrica!**

Apenas electricistas e pessoas com formação electotécnica podem executar os trabalhos que a seguir se descrevem.

**(sv)**

**Livsfara genom elektrisk ström!**

Endast utbildade elektriker och personer som undervisats i elektroteknik får utföra de arbeten som beskrivs nedan.

**(fi)**

**Hengenvaarallinen jännite!**

Vain pätevät sähköasentajat ja opastusta saaneet henkilöt saavat suorittaa seuraavat työt.

**(cs)**

**Nebezpečí úrazu elektrickým proudem!**

Níže uvedené práce smějí provádět pouze osoby s elektrotechnickým vzděláním.

**(et)**

**Eluohhtlik! Elektrilöögiolt!**

Järgnevalt kirjeldatud töid tohib teostada ainult elektriala spetsialist või elektrotehnilise instrueerimise läbinud personal.

**(hu)**

**Életveszély az elektromos áram révén!**

Csak elektromos szakemberek és elektrotechnikában képzett személyek végezhetik el a következőkben leírt munkákat.

**(lv)**

**Elektriskā strāva apdraud dzīvību!**

Tālāk aprakstītos darbus drīkst veikt tikai elektrospeciālisti un darbam ar elektrotehnikām iekārtām instruētās personas!

**(lt)**

**Pavojus gyvybei dėl elektros srovės!**

Tik elektrikai ir elektrotechnikos specialistai gali atlikti žemiau aprašytus darbus.

**(pl)**

**Porażenie prądem elektrycznym stanowi zagrożenie dla życia!**

Opisane poniżej prace mogą przeprowadzać tylko wykwalifikowani elektrycy oraz osoby odpowiednio poinstruowane w zakresie elektrotechniki.

**(sl)**

**Življenjska nevarnost zaradi električnega toka!**

Spodaj opisana dela smejo izvajati samo elektrostrokovnjaki in elektrotehnično poučene osebe.

**(sk)**

**Nebezpečenstvo ohrozenia života elektrickým prúdom!**

Práce, ktoré sú nižšie opísané, smú vykonávať iba elektroodborníci a osoby s elektrotechnickým vzdelaním.

**(bg)**

**Опасност за живота от електрически ток!**

Операциите, описани в следващите раздели, могат да се извършват само от специалисти-електротехници и инструктиран електротехнически персонал.

**(ro)**

**Atenție! Pericol electric!**

Toate lucrările descrise trebuie efectuate numai de personal de specialitate calificat și de persoane cu cunoaștințe profunde în electrotehnică.

**(hr)**

**Opasnost po život uslijed električne struje!**

Radove opisane u nastavku smiju obavljati samo stručni električari i osobe koje su prošle elektrotehničku obuku.

DC1-S1...

DC1-S2...

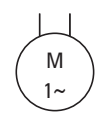
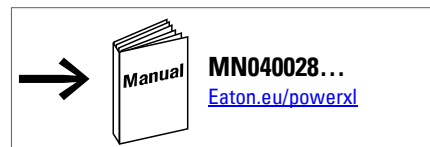

Single Phase AC Motor

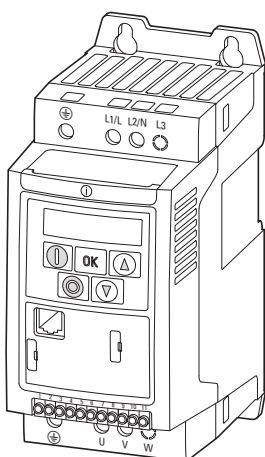

FS1  
IP20, NEMA 0

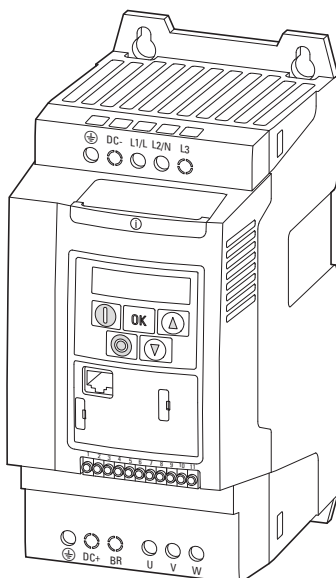

FS2  
IP20, NEMA 0



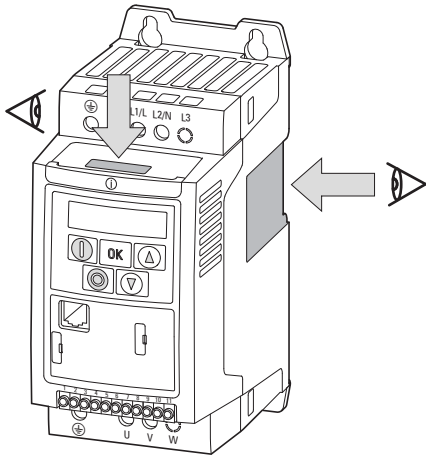

DC1-S 2 zzz F N-A20 N

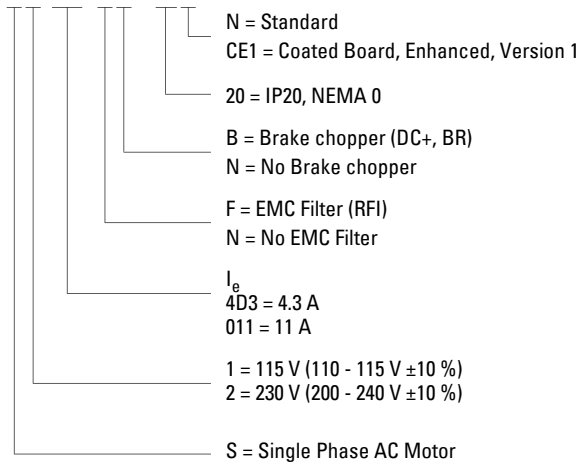

- (en) **Dimensions and weights**
- (de) **Abmessungen und Gewichte**
- (fr) **Encombresments et poids**
- (es) **Dimensiones y pesos**
- (it) **Dimensioni e pesi**
- (zh) **尺寸和重量**

- (ru) **Размеры и вес**
- (nl) **Afmetingen en gewichten**
- (da) **Mål og vægt**
- (el) **Διαστάσεις και βάρη**
- (pt) **Medições e pesos**
- (sv) **Dimensioner och vikter**

- (fi) **Mitat ja painot**
- (cs) **Rozměry a hmotnosti**
- (et) **Mõõtmed ja kaalud**
- (hu) **Méreték és Súly**
- (lv) **Izmēri un svars**
- (lt) **Matmenys ir svoriai**

- (pl) **Wymiary i masy**
- (sl) **Dimenzije in teže**
- (sk) **Rozmery a hmotnosti**
- (bg) **Размери и тегло**
- (ro) **Dimensiuni și greutateți**
- (hr) **Dimenzije i težina**

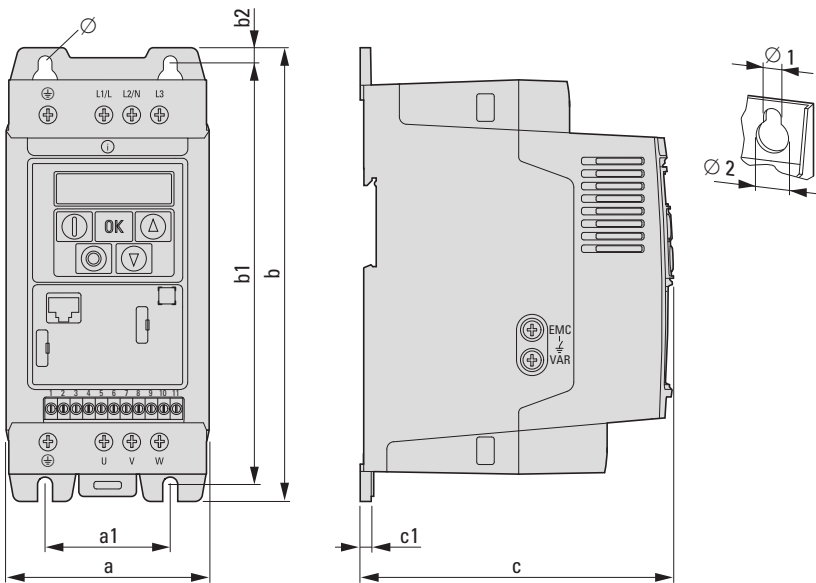

→ 1 inch = 25.4 mm  
 1 mm = 0.0394 inch  
 1 inch = 1"

[mm (in)]

FS		a	a1	b	b1	b2	c	c1	Ø 1	Ø 2	kg (lbs)
FS1	DC1-S17D0...	81 (3.19)	50 (1.97)	184 (7.24)	170 (6.69)	7 (0.28)	124 (4.88)	4 (0.16)	6 (0.24)	12 (0.47)	1.1 (2.43)
	DC1-S24D3...										
	DC1-S27D0...										
FS2	DC1-S1011...	107 (4.21)	75 (2.95)	231 (9.09)	215 (8.46)	8 (0.31)	152 (5.98)	5 (0.2)	6 (0.24)	12 (0.47)	2.6 (5.73)
	DC1-S2011...										

05/18 IL04020014Z

- (en) Mounting on metal plate
- (de) Montage auf Metallplatte
- (fr) Montage sur platine métallique
- (es) Montaje sobre una placa de metal
- (it) Montaggio su piastra metallica
- (zh) 安装到金属板上
- (ru) Монтаж на металлической пластине
- (nl) Montage op metalen plaat

- (da) Monterिंग på metalplade
- (el) Εγκατάσταση σε μεταλλικό έλασμα
- (pt) Montagem na placa de metal
- (sv) Montering på metallplatta
- (fi) Asennus metallilevyllä
- (cs) Montáž na kovovou desku
- (et) Montáž na koonuú dosku
- (hu) Szerelés fémlemezre

- (lv) Montāža uz metāla plāksnes
- (lt) Montavimas ant metalinės plokštės
- (pl) Montaż na metalowej płytce
- (sl) Montāža na kovinsko ploščo
- (sk) Montáž na kovonú dosku
- (bg) Монтаж върху метална планка
- (ro) Montare pe placă metalică
- (hr) Montāža na metalnu ploču

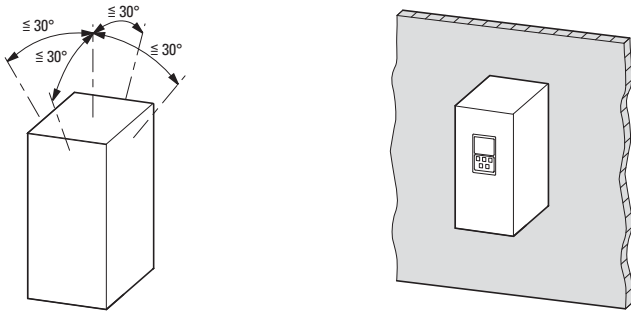

05/18 IL04020014Z

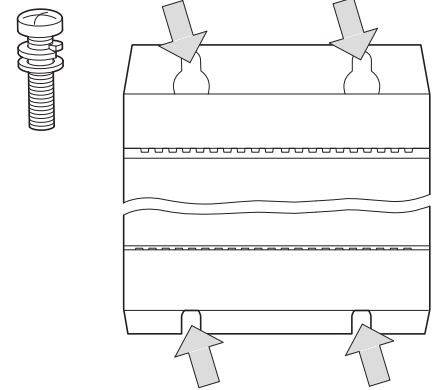
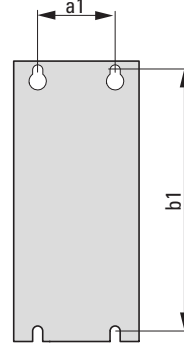
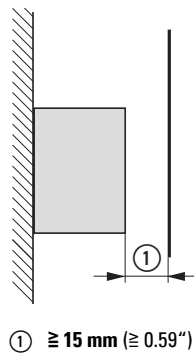
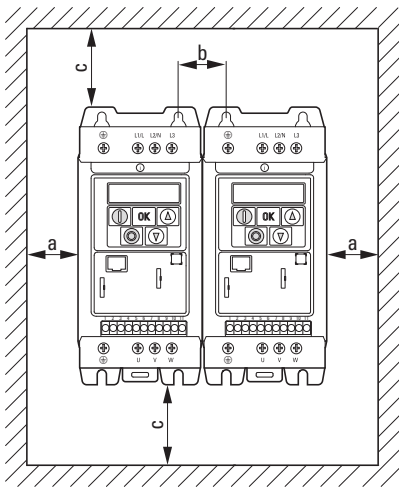

FS1, FS2: = 4 x M4  
1 Nm (8.85 lb-in)

	a mm (in)	b mm (in)	c mm (in)	V m <sup>3</sup> /h (cfm)
FS1	50 (1.97)	46 (1.81)	75 (2.95)	18.69 (11)
FS2	50 (1.97)	46 (1.81)	75 (2.95)	18.69 (11)

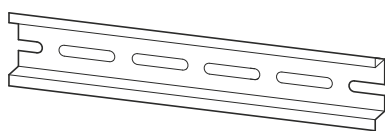

IEC/EN 60715

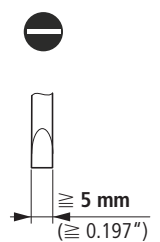
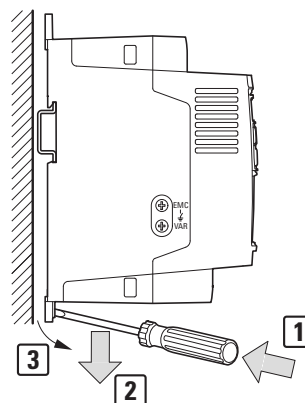
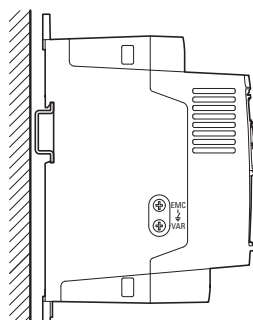
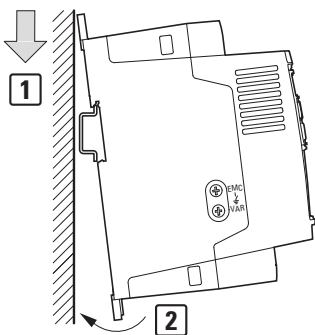
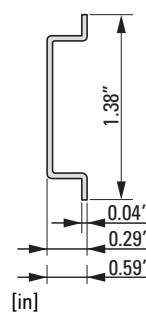
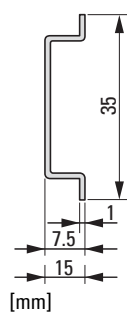

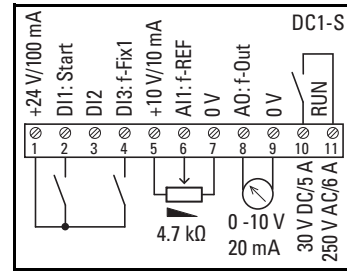
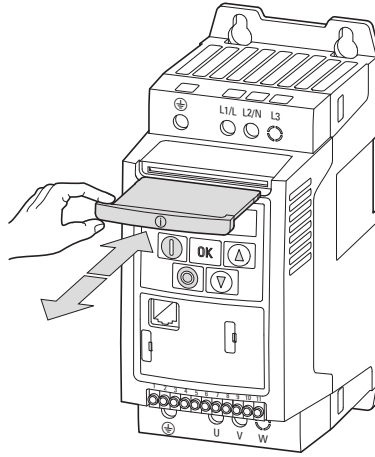
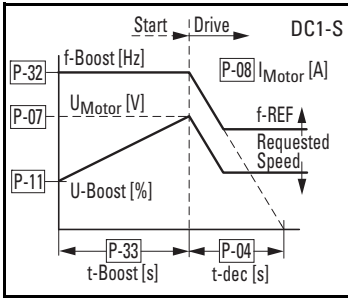

RJ45 (CANopen, Modbus RTU)

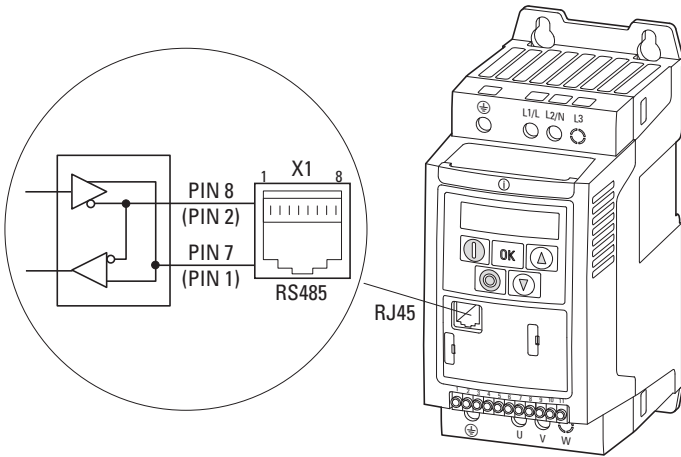

PIN 1	CANopen -
PIN 2	CANopen +
PIN 3	0 V
PIN 4	OP-Bus -
PIN 5	OP-Bus +
PIN 6	+24 V
PIN 7	Modbus RTU (A), RS485 -
PIN 8	Modbus RTU (B), RS485 +

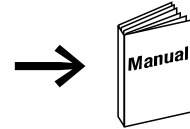

Mains (TN, TT)

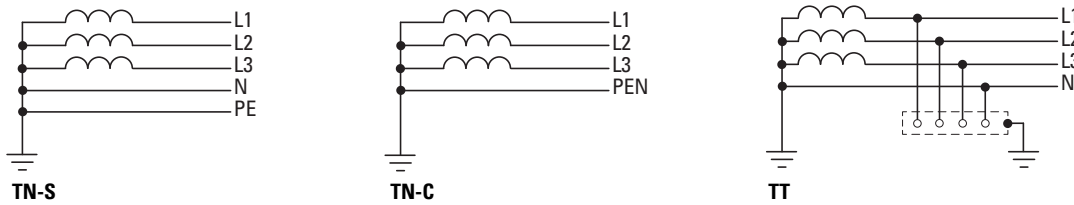

DC1-S1..., DC1-S2...

Mains,  $U_{LN} = 1 \sim 110 - 115 \text{ V} \pm 10 \%$   
 $U_{LN} = 1 \sim 200 - 240 \text{ V} \pm 10 \%$

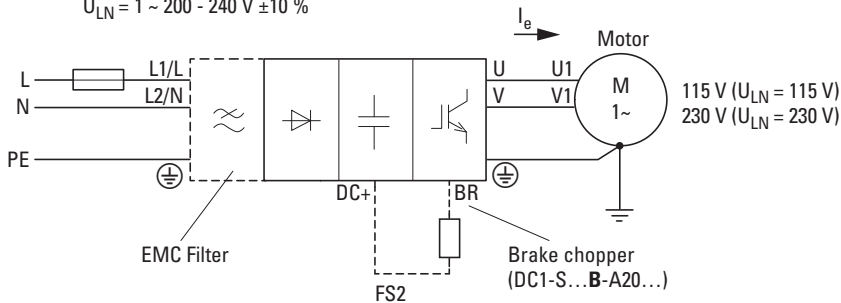

with EMC filter	with Brake chopper
DC1-S24D3FN-A20...	DC1-S1011NB-A20...
DC1-S27D0FN-A20...	DC1-S2011NB-A20...
DC1-S2011FB-A20...	DC1-S2011FB-A20...

<p><b>en NOTICE</b> Connect only in voltage-free state!</p> <p><b>de ACHTUNG</b> Nur im spannungsfreien Zustand anschließen!</p> <p><b>fr ATTENTION</b> Raccordez l'appareil uniquement hors tension !</p> <p><b>es CUIDADO</b> ¡Conectar únicamente en estado sin tensión!</p> <p><b>it AVVISO</b> Collegare solo in assenza di tensione!</p> <p><b>zh 注意</b> 必须在断电状态下进行连接！</p> <p><b>ru ВНИМАНИЕ</b> Подключать только в обесточенном состоянии!</p> <p><b>nl OPGELET</b> Alleen in spanningsloze toestand aansluiten!</p>	<p><b>da VIGTIGT</b> Må kun tilsluttes i spændingsfri tilstand!</p> <p><b>el ΕΠΙΓΡΥΠΝΗΣΗ</b> Συνδέστε μόνο όταν δεν επικρατεί τάση!</p> <p><b>pt ADVERTÊNCIA</b> Ligar apenas com a tensão desligada!</p> <p><b>sv OBSERVERA</b> Får endast anslutas i spänningsfritt tillstånd!</p> <p><b>fi ILMOITUS</b> Kytke vain jännitteettömässä tilassa!</p> <p><b>cs UPOZORNĚNÍ</b> Připojujte jen při zcela odpojeném napájení!</p> <p><b>et TÄHELEPANU</b> Ühendada ainult pingevabas olekus!</p> <p><b>hu FIGYELEM</b> Csak feszültségmentes állapotban csatlakoztassa!</p>	<p><b>lv UZMANĪBU</b> Pieslēgt tikai tad, kad nenotiek sprieguma padeve!</p> <p><b>lt DĖMESIO</b> Prijungti tik tada, kai išjungta įtampa!</p> <p><b>pl UWAGA</b> Podłączać zawsze po uprzednim odłączeniu od zasilania elektrycznego!</p> <p><b>sl POZOR</b> Napravo priključite le, ko ni pod napetostjo!</p> <p><b>sk UPOZORNENIE</b> Napájať len v stave bez napätia!</p> <p><b>bg ПРЕДУПРЕЖДЕНИЕ</b> Свързвайте само, когато уреда не е под напрежение!</p> <p><b>ro ATENTJE</b> Conectați doar când aparatul nu se află sub tensiune!</p> <p><b>hr POZOR</b> Priključujte samo u beznaponskom stanju!</p>
--	---	---

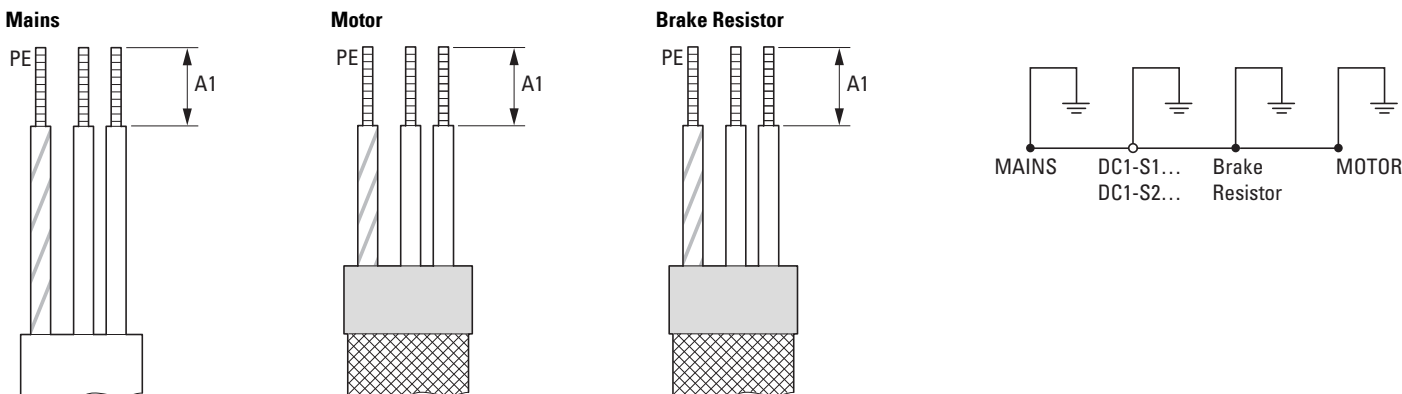

05/18 IL04020014Z

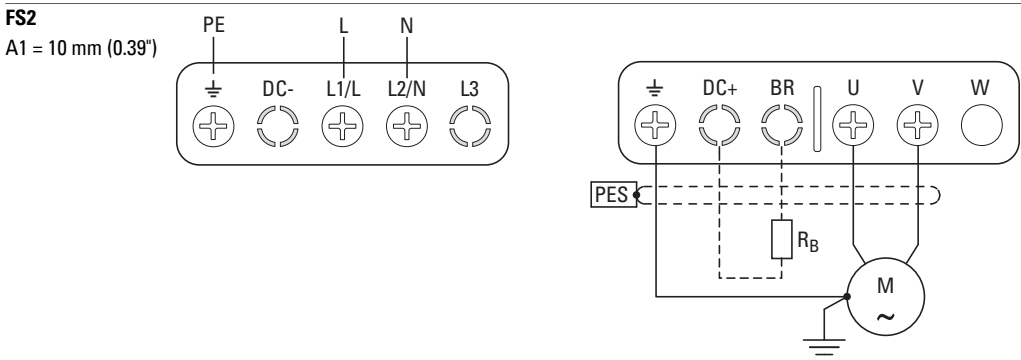
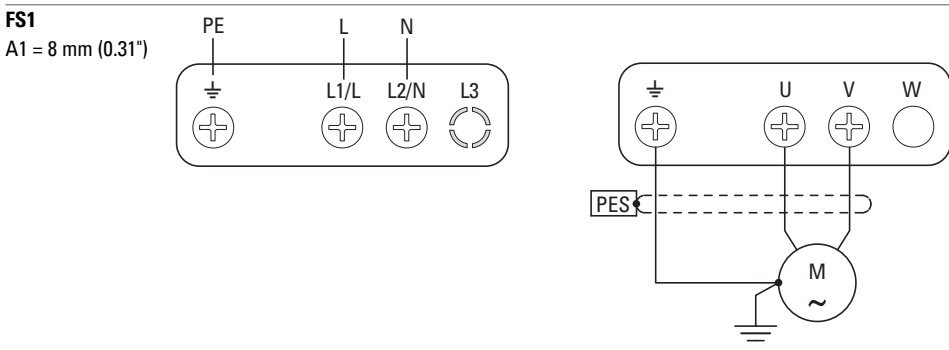

Power		
<b>A (max.)</b>	<b>1 Nm</b> (8.85 lb-in)	<b>PH2</b>
8 mm <sup>2</sup> (AWG 8)		

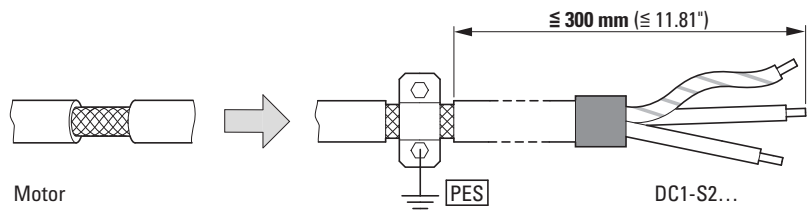

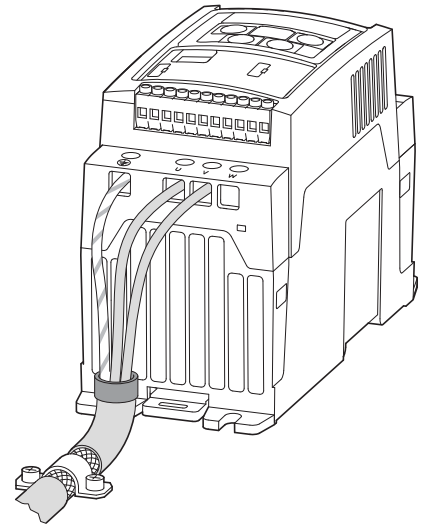
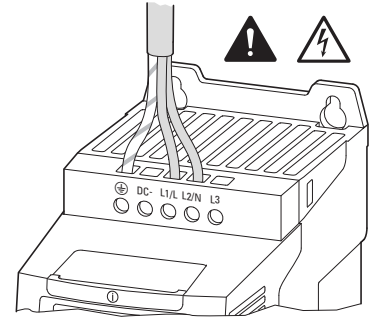
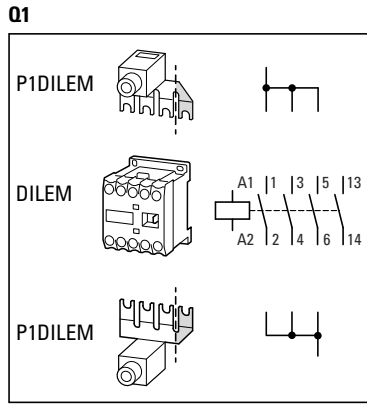
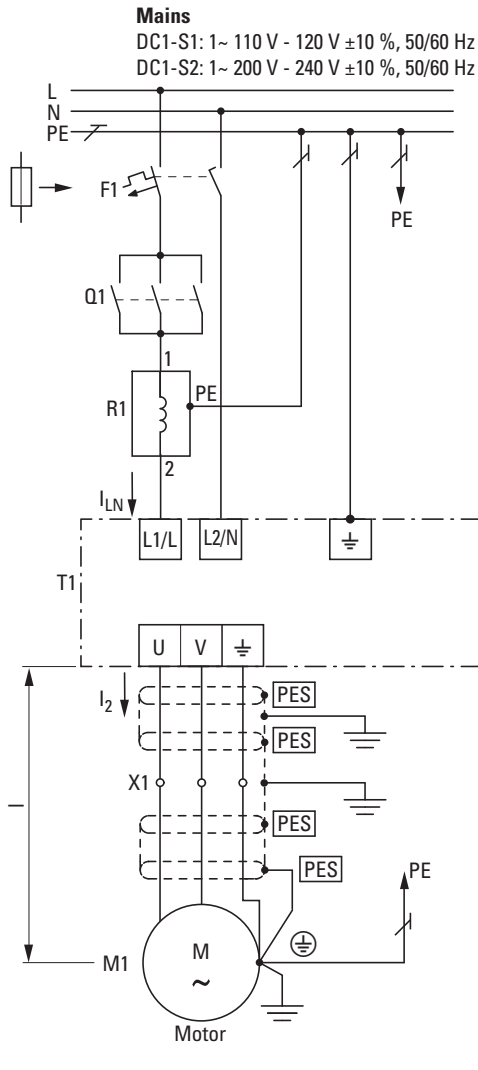

EMC	I	DC1
C2	≤ 5 m ≤ 16.4 ft	DC1-S24D3FN-A20...
C3	≤ 25 m ≤ 82.02 ft	DC1-S27D0FN-A20... DC1-S2011FB-A20...

Type	Frame Size	Mains					Rated Output Current			Motor		Brake Resistor
		$I_{LN}$ A	F1/Q1 <sup>1)</sup> Fuse or MCB (Type B, gG, J) IEC UL <sup>1)</sup>	A mm <sup>2</sup>	AWG kcmil	A mm <sup>2</sup>	A mm <sup>2</sup>	AWG kcmil	P kW	HP	$R_{B\ res}$ Ω	
DC1-S17D0...	FS1	8.5	16	15	2.5	14	7	1.5	16	0.37	0.5	-
DC1-S1011...	FS2	12.5	16	15	2.5	14	10.5	1.5	16	0.55	0.75	100
DC1-S24D3...	FS1	6	10	10	1.5	16	4.3	1.5	16	0.37	0.5	-
DC1-S27D0...	FS1	9.3	16	15	2.5	14	7	1.5	16	0.75	1	-
DC1-S2011...	FS2	14	20	20	2.5	14	10.5	1.5	16	1.1	1.5	100

1) Maximum supply short-circuit current: 100 kA rms (AC)

- AWG = American Wire Gauge.  
 (en) Smaller numbers represent increasing wire thickness.  
 (de) Kleinere Zahlen stehen für ansteigende Drahtstärke.

**Motor (M1)**

- DC1-S1...: kW @ 115 V, 50 Hz, 1500 min<sup>-1</sup>  
 HP @ 115 V, 60 Hz, 1800 rpm  
 DC1-S2...: kW @ 230 V, 50 Hz, 1500 min<sup>-1</sup>  
 HP @ 230 V, 60 Hz, 1800 rpm

05/18 IL04020014Z

## Control Terminals

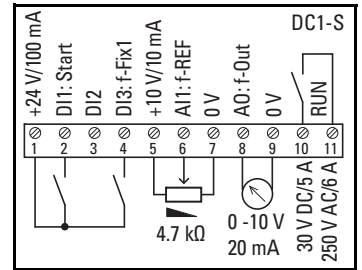
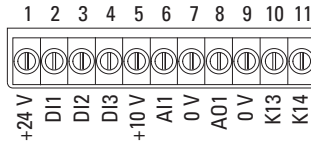
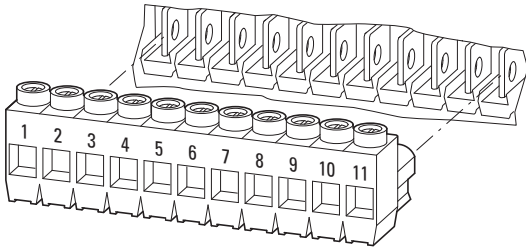

mm <sup>2</sup>	mm <sup>2</sup>	AWG	mm	in	M3	lb-in	mm
0.25 - 0.5	0.14 - 1.5	26 - 16	5	0.2			0.4 x 2.5

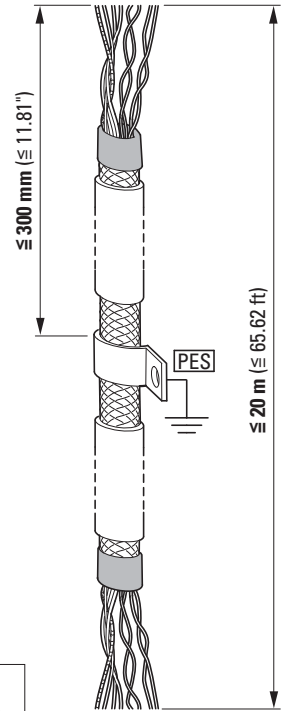

05/18 IL04020014Z

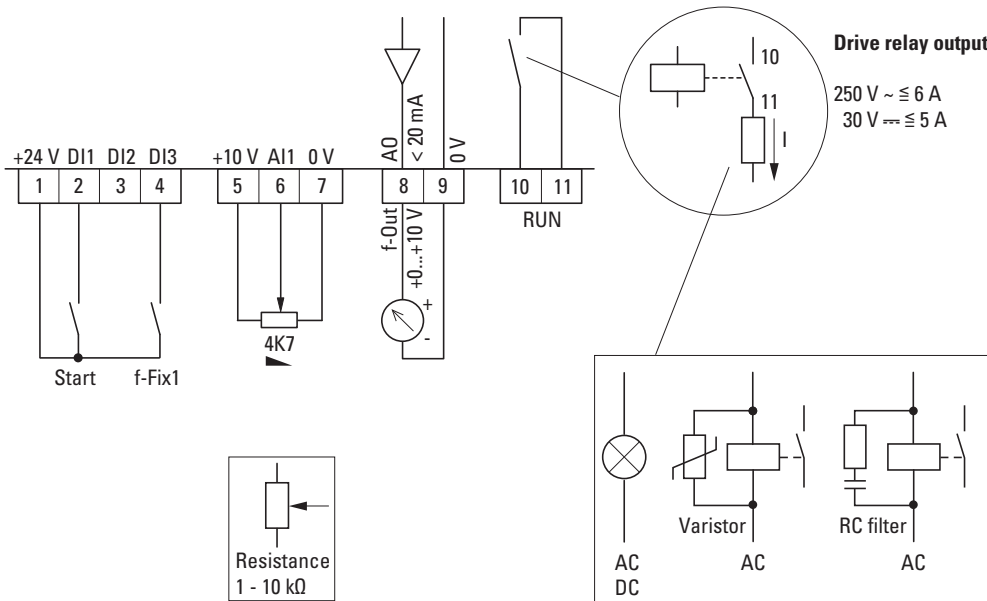

## Motor Protection

- |                        |                      |                        |                      |                        |                     |
|------------------------|----------------------|------------------------|----------------------|------------------------|---------------------|
| <b>en</b> Thermistor   | <b>it</b> Termistore | <b>da</b> Thermistor   | <b>fi</b> Termistori | <b>lv</b> Termistors   | <b>sk</b> Termistor |
| <b>de</b> Thermistor   | <b>zh</b> 热敏电阻       | <b>el</b> Θερμίστορ    | <b>cs</b> Termistor  | <b>lt</b> Termistorius | <b>bg</b> Термистор |
| <b>fr</b> Thermistance | <b>ru</b> Термистор  | <b>pl</b> Thermistance | <b>et</b> Termistor  | <b>sl</b> Termistor    | <b>ro</b> Termistor |
| <b>es</b> Termistor    | <b>nl</b> Thermistor | <b>sv</b> Termistor    | <b>hu</b> Termisztor | <b>si</b> Termistor    | <b>hr</b> Termistor |

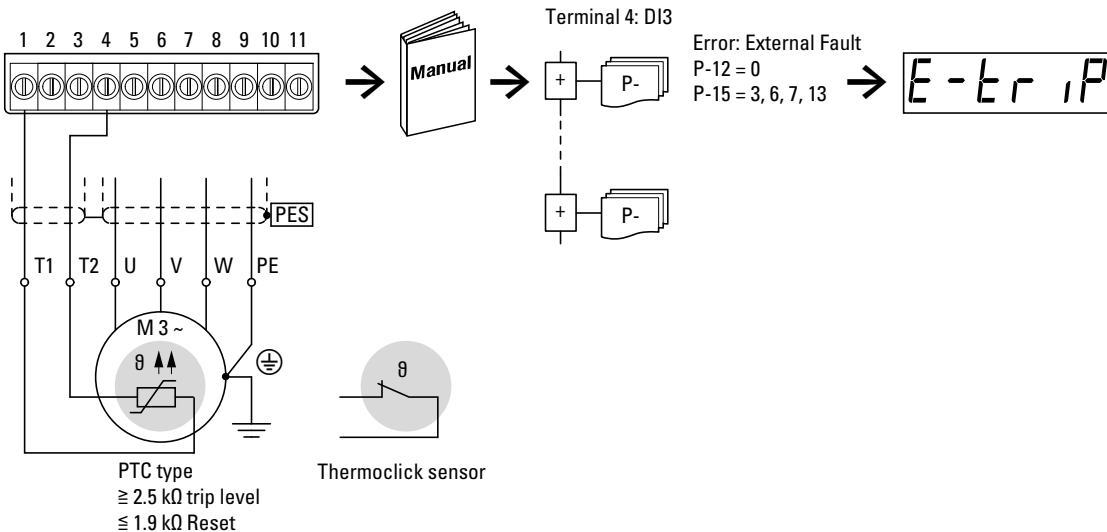

# DC1-S1..., DC1-S2...

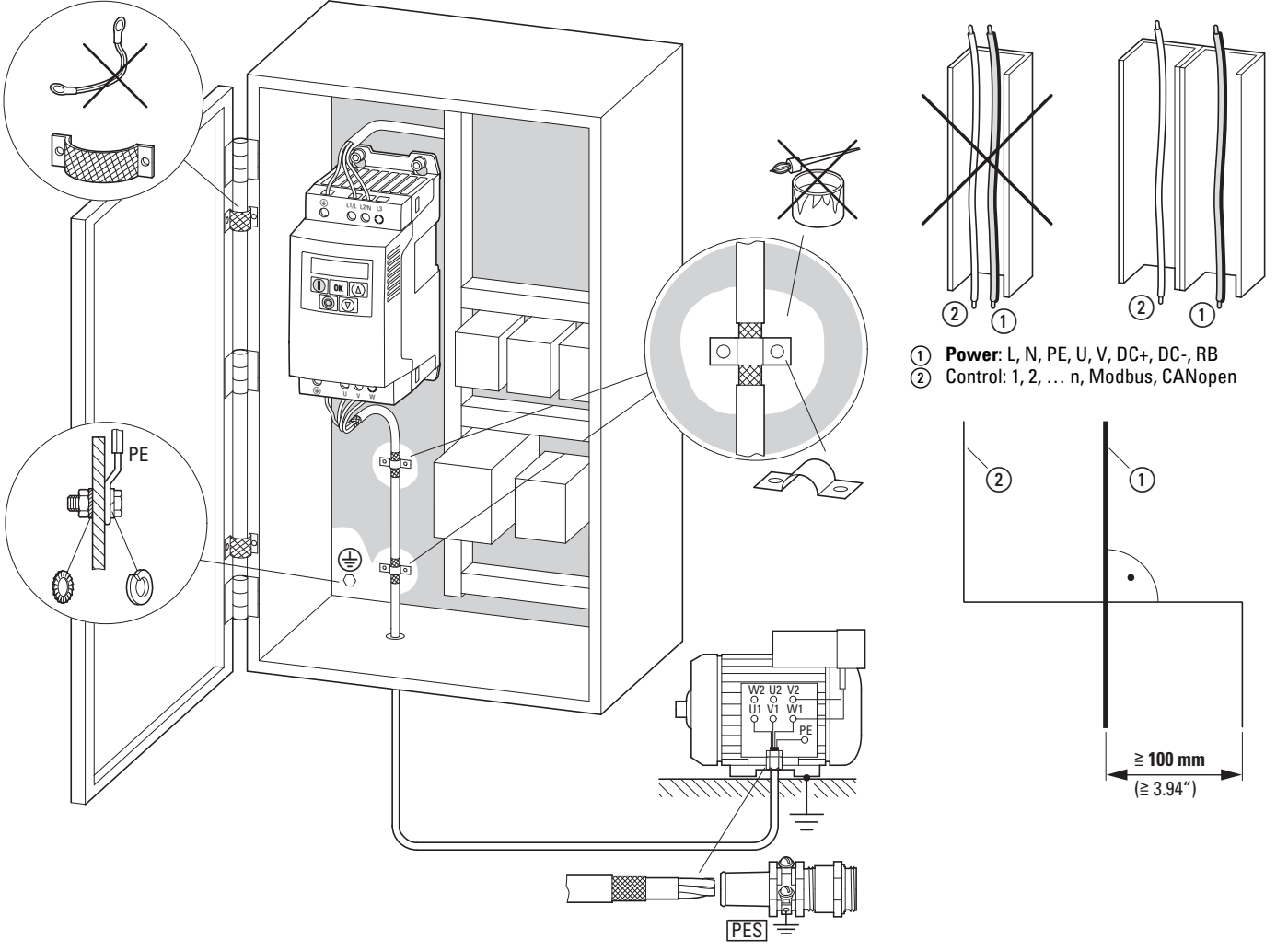
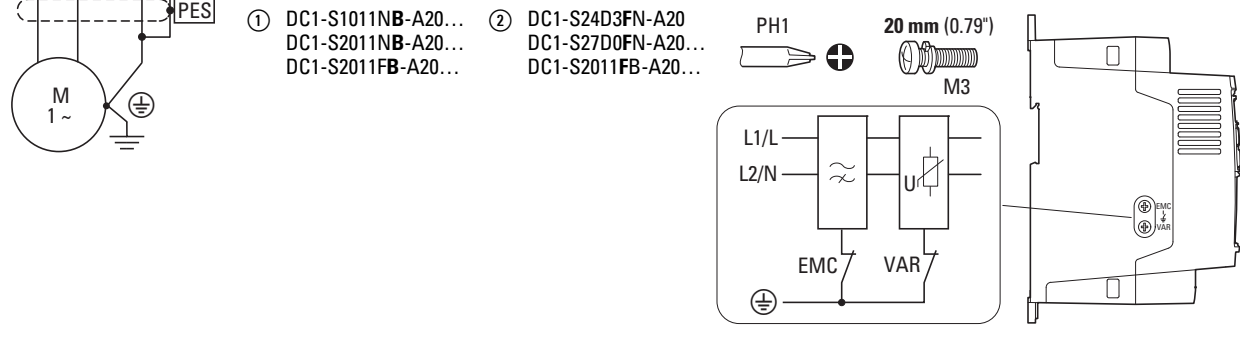
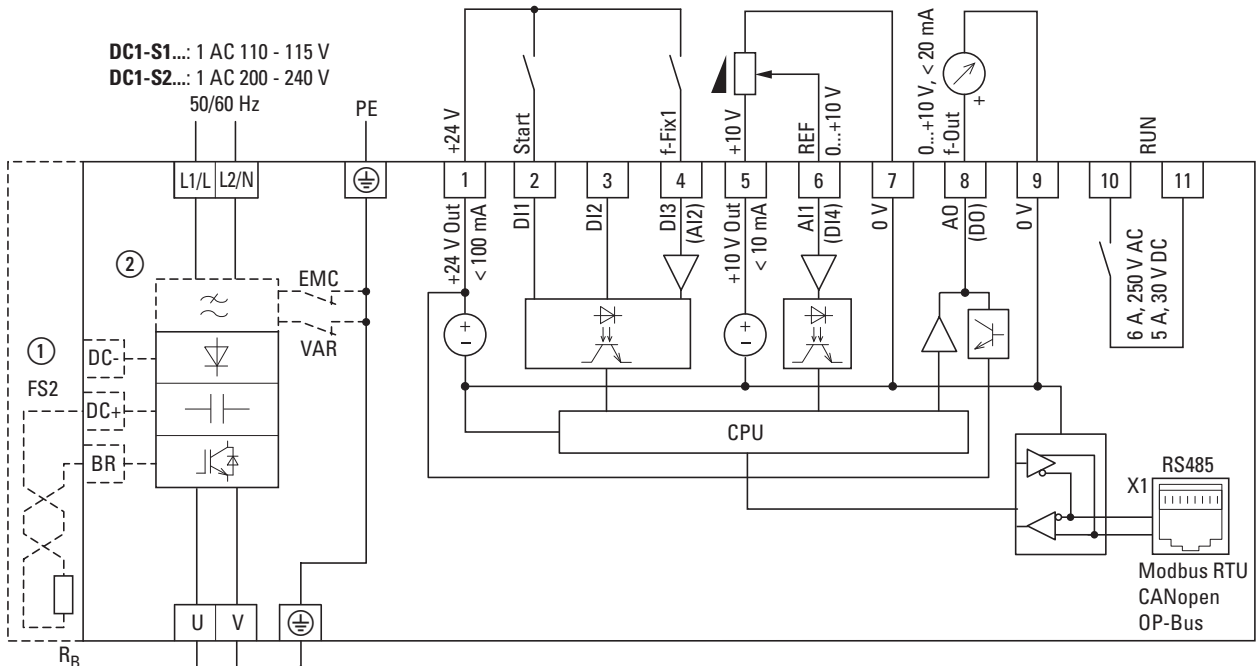

05/18 IL04020014Z



**en Single-phase motor – de Einphasen Wechselstrommotor**

**en Shaded pole motor – de Spaltpolmotor**

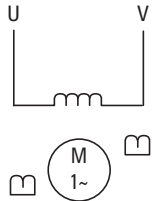
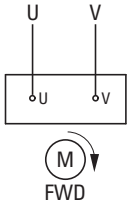
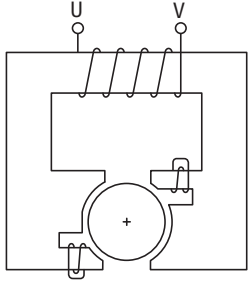

**en Permanent-split capacitor motor (PSC) – de Kondensatormotor**

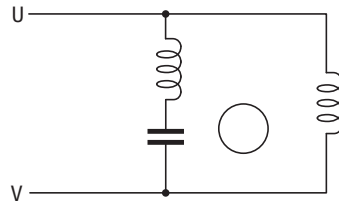
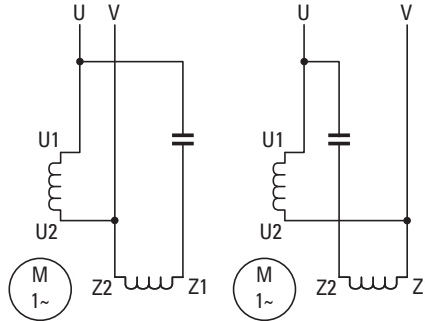
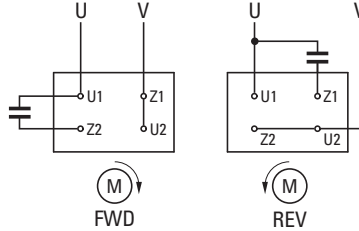
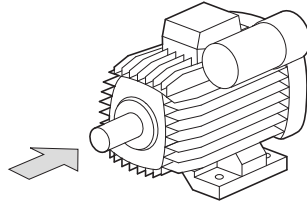

**en Single-phase supply from 3-phase motor (Steinmetz connection) – de Einphasige Einspeisung von 3-Phasen Motor (Steinmetzschaltung)**

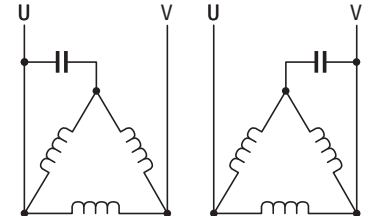
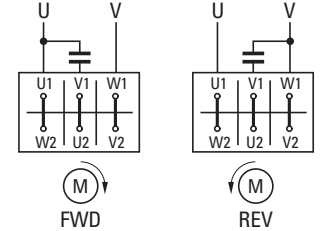
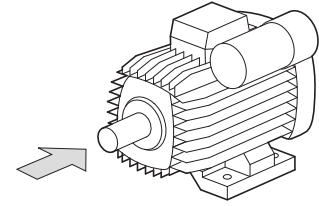

05/18 ILD4020014Z

**en Split-phase motor  
de Induktionsstartmotor**

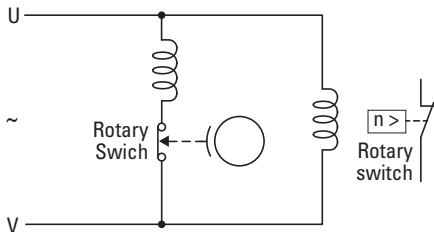

**en** Switches at 75 % of its rated speed  
**de** Schaltet bei 75 % der Nenndrehzahl

**en Capacitor-start induction motor  
de Kondensatormotor mit Start-Kondensator**

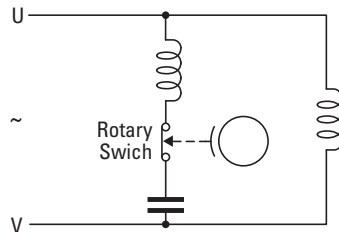

**en Capacitor-run induction motor  
de Kondensatormotor mit Start- und Betriebs-Kondensator**

**!** **en** not allowed  
**de** nicht erlaubt

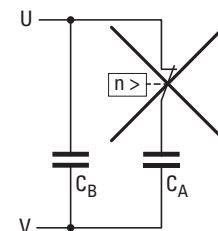
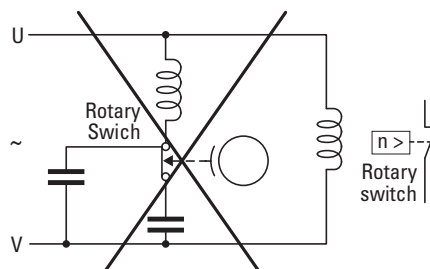

## Parameter: Boost Starting Cycle (Setup Parameter)

- (en) The start area must be defined.
- (de) Der Startbereich muss parametrieren werden.
- (fr) La plage de démarrage est à paramétrer.
- (es) Debe parametrizarse el área de inicio.
- (it) L'area di avvio deve essere parametrizzata.
- (zh) 启动范围必须进行参数设置。
- (ru) Необходимо настроить область запуска.
- (nl) Het startgebied moet worden geparastreerd.
- (da) Startområdet skal parametreses.
- (el) Η περιοχή εκκίνησης πρέπει να καθορίζεται.
- (pt) A área de início deve ser parametrizada.
- (sv) Startområdet måste definieras.
- (fi) Käynnistysalue täytyy parametroida.
- (cs) Je nutná parametrizace počáteční oblasti.
- (et) Startiala parameetrid tuleb määratleda.
- (hu) Az indító területet paraméterezni szükséges.
- (lv) Jānorāda palaišanas zona.
- (lt) Reikia nustatyti pradinės srities parametrus.
- (pl) Konieczne jest sparametryzowanie zakresu startowego.
- (sl) Začetno območje mora biti definirano.
- (sk) Je treba parametrizovať počiatočnú oblasť.
- (bg) Параметрите на началната зона трябва да бъдат определени.
- (ro) Zona de pornire trebuie să fie parametrizată.
- (hr) Valja definirati područje pokretanja.

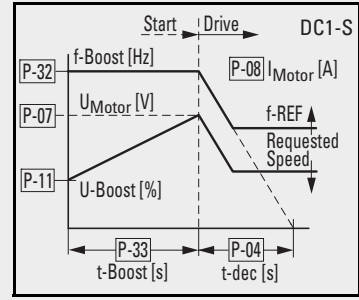
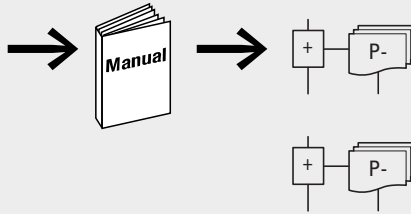

## Motor protection

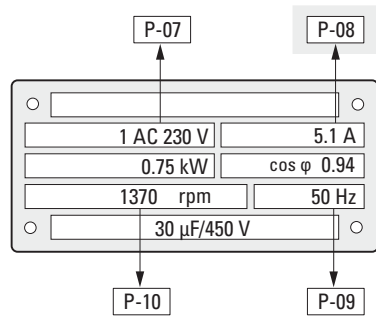

### Example

DC1-S27D0...: 1~230 V (P-07), 7 A (P-08)

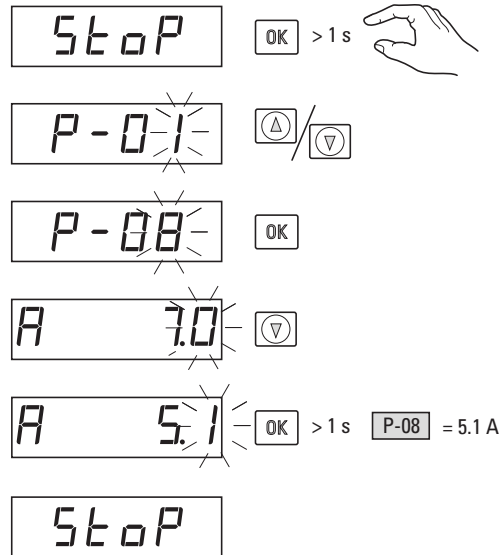

## Keypad Control

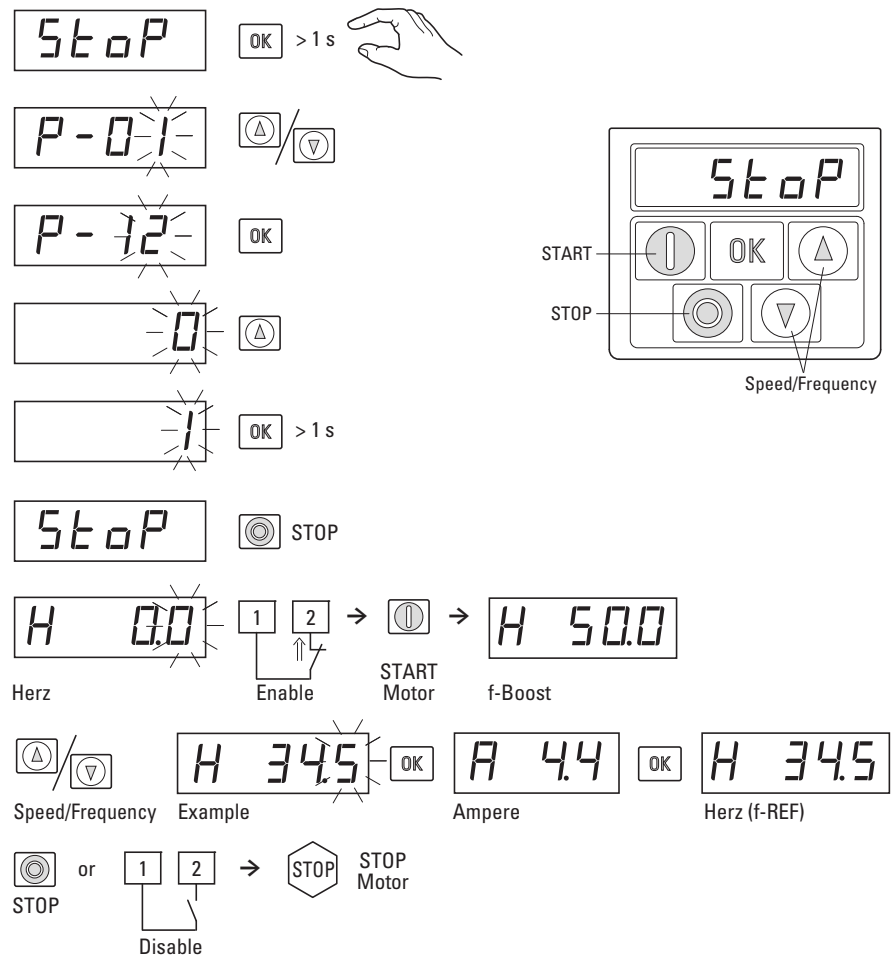

## Reset

- (en) Resetting the parameters to their default settings – (de) Rücksetzen der Parameter in die Werkseinstellung – (fr) Réinitialisation des paramètres sur réglage usine – (es) Restauración de los parámetros al ajuste de fábrica – (it) Ripristino delle impostazioni di fabbrica – (zh) 复位机器设置参数 – (ru) Сброс параметров на заводские установки – (nl) Resetten van de parameters naar de fabrieksinstelling – (da) Tilbagestilling af parametrene til fabriksindstillingen – (el) Επαναφορά των παραμέτρων στις εργοστασιακές ρυθμίσεις – (pt) Redefinição dos parâmetros na regulagem de fábrica – (sv) Återställa parametrerna fabriksinställning – (fi) Parametrien palauttaminen tehdasasetukseen – (cs) Navrácení parametrů na nastavení z výroby – (et) Parameetrite lähtestamine algseadistusele – (hu) Paraméterek visszaállítása gyári beállításokra – (lv) Rūpnīcas parametru atiestatīšana – (lt) Parametų gamyklinių nuostatų atstatymas – (pl) Resetowanie ustawień do parametrów fabrycznych – (sl) Povrnitev parametrov na tovarniško nastavitve – (sk) Obnovenie parametrov do továrenského nastavenia – (bg) Нулиране на параметър в заводска настройка – (ro) Resetarea parametrilor la setarea din fabrică – (hr) Vraćanje parametara na tvorničke postavke

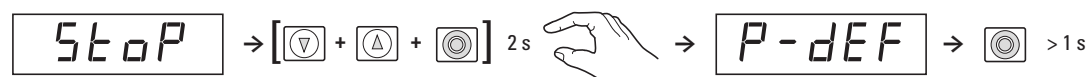

# Additional Information for UL<sup>®</sup> Approved Installations

→ Refer to Manual MN040028EN

DC1 is designed to meet the UL requirements. In order to ensure full compliance, the following must be fully observed.

Input Power Supply Requirements				
<b>Supply Voltage</b>	DC1-S1...	110 - 115 RMS Volt for 115 Volt rated units, ±10 % variation allowed. 115 Volt RMS Maximum		
	DC1-S2...	200 - 240 Volt for 230 Volt rated units, ±10 % variation allowed. 240 Volt RMS Maximum		
<b>Imbalance</b>	Maximum 3 % voltage variation between phase – phase voltages allowed All DC1 units have phase imbalance monitoring. A phase imbalance of > 3 % will result in the drive tripping. For input supplies which have supply imbalance greater than 3 % Eaton Drives recommends the installation of input line reactors.			
<b>Frequency</b>	50 - 60 Hz ±5 % Variation			
<b>Short Circuit Capacity</b>	<b>Voltage Rating</b>	<b>Min. kW (HP)</b>	<b>Max. kW (HP)</b>	<b>Maximum supply short-circuit current</b>
	115 V	0.37 (0.5)	0.75 (1)	100 kA rms (AC)
	230 V	0.37 (0.5)	1.1 (1.5)	100 kA rms (AC)
All the drives in the above table are suitable for use on a circuit capable of delivering not more than the above specified maximum short-circuit Amperes symmetrical with the specified maximum supply voltage.				

General Requirements			
<b>Mechanical Installation Requirements</b>			
All DC1 units are intended for indoor installation within controlled environments which meet the condition limits:			
<ul style="list-style-type: none"> <li>– for IP20 (NEMA 0) units, installation is required in a pollution degree 1 environment.</li> <li>– for IP66 (NEMA 4X) units, installation in a pollution degree 2 environment is permissible.</li> </ul>			
<b>Ambient temperature range</b>	Operational	-10 °C to 50 °C (14 °F to 122 °F), to 60 °C (140 °F) with derating (frost and condensation free)	
	Storage and Transportation	-40 °C to 60 °C (-40 °F to 140 °F)	
<b>Relative Humidity</b>	< 95 % (non condensing). Drive must be Frost and moisture free at all times.		
<b>Max. altitude for rated operation</b>	1000 m. Derate above 1000 m: 1 % / 100 m. Installation above 2000 m is not UL approved.		

- Electrical Installation Requirements**
- For 1 phase supply, power must be connected to terminals L1/L and L2/N.
  - For compliance with CE and C Tick EMC requirements, a symmetrical shielded motor cable is recommended.
  - A fixed installation is required according to IEC 61800-5-1 with a suitable disconnecting device installed between the DC1 and the AC Power Source. The disconnecting device must conform to the local safety code/regulations (e. g. within Europe, EN 60204-1, Safety of Machinery).
  - The cables must be dimensioned according to the local codes or regulations. Motor Cable: 75 °C (167 °F) Copper must be used.
  - Suitable fuses to provide wiring protection of the input power cable should be installed in the incoming supply to the data shown in this Instruction Leaflet.
  - The fuses must comply with any local codes or regulations in place. In general, type gG (IEC 60269) or UL Class J fuses are suitable. The max. Voltage rating for fuses is 600 V.
  - Where allowed by local regulations, suitably dimensioned type B MCB circuit breakers of equivalent rating may be utilised in place of fuses, providing that the clearing capacity is sufficient for the installation. The max. Voltage rating for MBCs is 480 V.
  - When the power supply is removed from the drive, a minimum of 30 seconds should be allowed before re-applying the power. A minimum of 5 minutes should be allowed before removing the terminal covers or connection.
  - Transient surge suppression must be installed on the line side of this equipment and shall provide protection for a rated impulse withstand voltage peak of 4 kV.
- Only a single conductor type is allowed in each field wiring terminal when connected in group installation arrangement.

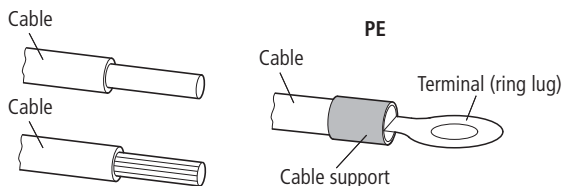

- Motor Overload Protection**
- DC1 provides motor overload protection in accordance with the National Electrical Code (US).
- Where a motor thermistor is not fitted, or not utilised, Thermal Overload Memory Retention must be enabled by setting P-51 = 0. Set the parameters P1-08 "Current Limit" on motor current.
  - Where a motor thermistor is fitted and connected to the drive, connection must be carried out according to the information, refer to Manual.

05/18 IL04020014Z



## en CAUTION

In the territory of the EU Directive the frequency-controlled devices and their accessories must be taken into operation only when the machine has been determined to fulfil the protection requirements of Machinery Directive 2006/42/EC.

Ensure EMC-compliant installation. Lay control and communication cables spatially separated from the motor cable. Ensure a large contact area connection between [PES] cable screen and PE.

## de VORSICHT

Im Geltungsbereich der EG-Richtlinien dürfen die frequenzgesteuerten Geräte und deren Zubehör nur dann in Betrieb genommen werden, wenn festgestellt wird, dass die Maschine die Schutzanforderungen der Maschinenrichtlinie 2006/42/EG erfüllt.

EMV-gerechter Aufbau. Steuer- und Netzleitungen räumlich getrennt von der Motorleitung verlegen. [PES] Leitungsschirm großflächig mit PE verbinden.

## fr AVERTISSEMENT

En application des directives européennes, les convertisseurs de fréquence et leurs accessoires ne doivent être mis en service que s'il a été vérifié que la machine répond aux exigences de la directive machines 2006/42/CE.

Montage conforme aux règles de la CEM. Eloigner les câbles de commande et de réseau des câbles puissance. Relier le blindage au PE en assurant de grandes surfaces de contact.

## es ATENCIÓN

En el campo de aplicación de la normativa CE, los dispositivos controlados por frecuencia y sus correspondientes accesorios sólo deberán ponerse en marcha cuando se asegure que la máquina cumple con las exigencias de seguridad de la normativa de máquinas 2006/42/CE.

El montaje debe cumplir CEM. Los cables de mando y de conexión a red se deben instalar independientemente del cable de conexión al motor. El cable apantallado [PES] se debe conectar a masa utilizando una amplia superficie de contacto.

## it ATTENZIONE

Nel campo di validità della direttiva CE, gli apparecchi a controllo di frequenza e i loro accessori possono essere messi in esercizio soltanto se si verifica che la macchina soddisfa i requisiti di sicurezza della direttiva macchine 2006/42/CE

Montaggio secondo CEM. Disporre i cavi comandi e di alimentazione separati dal cavo del motore. Collegare lo schermo del cavo [PES] con PE con un'ampia superficie.

## zh 小心

根据欧盟设备一致性规范，安装频率控制设备及其配件时，应确保设备满足机器规范 2006/42/EG 中关于设备保护的要求。

[PES] 按照电磁兼容规范正确安装。应将控制电缆和电源电缆与机电电缆分开。大面积采用 PE 包裹电缆。

## ru ОСТОРОЖНО

В сфере действия директив ЕС устройства с частотным управлением и их оснащение должны вводиться в эксплуатацию только в том случае, если установлено, что данное оборудование соответствует требованиям по защите Директивы о машинном оборудовании 2006/42/ЕС.

Сборка соответственно электромагнитной совместимости. Линии управления и электросети прокладывать в пространственном отношении отдельно от линии двигателя. [PES] силовой экран соединять с PE по большой площади.

## nl VOORZICHTIG

Binnen het geldigheidsgebied van de EC-richtlijnen mogen de frequentieregelderde apparaten en de toebehoren daarvan alleen in bedrijf worden genomen, wanneer wordt vastgesteld, dat de machine aan de veiligheidsvoorschriften van de machinerichtlijn 2006/42/EG voldoet.

EMC-conforme constructie. Besturings- en netkabels ruimtelijk gescheiden van de motorkabel leggen. [PES] Kabelafscherming over groot oppervlak met PE verbinden.

## da FORSIGTIG

I det område, hvor EF-direktiverne er gældende, må det frekvensstyrede udstyr og dets tilbehør kun tages i anvendelse, hvis det konstateres, at maskinen opfylder beskyttelseskravene i maskindirektivet 2006/42/EF.

EMC-korrekt installation. Træk styre- og netledninger rumligt adskilt fra motorledningen. [PES] Sørg for en stor kontakflade mellem PES ledningsafskærmning og PE.

## el ΠΡΟΣΟΧΗ

Στο πεδίο εφαρμογής των οδηγιών της ΕΚ, οι ελεγχόμενες μέσω συχνότητας συσκευές και τα παρελκόμενά τους επτρέπεται να τίθενται σε λειτουργία μόνο εφόσον διαπιστωθεί ότι το μηχάνημα πληροί τις απαιτήσεις προστασίας της οδηγίας της ΕΚ για τα μηχανήματα 2006/42/ΕΚ.

Κατασκευή σύμφωνα με τις απαιτήσεις ΗΜΣ. Εγκαθιστάτε τους αγωγούς ελέγχου και δικτύου ανεξάρτητα από τον αγωγό του κινητήρα. [PES] Συνδέετε τη θωράκιση των αγωγών σε μεγάλη επιφάνεια με τη γείωση.

## pt CUIDADO

No âmbito das directivas da CE, os aparelhos comandados por frequência e os respectivos acessórios só podem ser postos em operação se for comprovado que a máquina atende às exigências de protecção da directiva de máquinas 2006/42/CE.

Estrutura com compatibilidade electromagnética. Dispon os fios de comando e de rede separados do fio do motor. [PES] Ligar uma área grande da blindagem do cabo (PES) com o PE.

## sv FÖRSIKTIG

I giltighetsområdet för EG-direktiven får de frekvensstyrda apparaterna och deras tillbehör endast tagas i drift när man fastställt att maskinen uppfyller skyddskraven i maskindirektiv 2006/42/EG.

EMC-anpassad uppbyggnad. Styr- och nätledningar dras avskilda från motorledningarna. [PES] Förbind ledningsskärm över ett brett område med PE.

## fi HUOMIO

EU-direktiivin voimassaoloalueella taajuusohjatut laitteet ja niiden varusteet saa ottaa käyttöön vain silloin, kun todetaan, että kone täyttää konedirektiivin 2006/42/EE suojausvaatimukset.

EMC-mukainen rakenne. Ohjaus- ja verkkojohdot on asennettava tilalotteisesti erotettuina. Johdonsuojat on liitettävä laajasti maadoitukseen [PES].

## cs POZOR

V rozsahu platnosti směrnice ES smí být frekvenčně řízené přístroje a jejich příslušenství uvedeno do provozu jediné tehdy, pokud je zjištěno, že stroj splňuje požadavky ochrany stanovené směrnicí 2006/42/ES o strojních zařízeních.

Nástavba odpovídající směrnici EMC. Řídící a síťová vedení pokládejte prostorově oddělená od vedení motoru. [PES] Stínění vedení spojte velkoplošně s PE.

## et ETTEVAATUST

EÜ-direktiivi kehtivuspiirkonnas võib sagedusjuhitavaid seadmeid ja nende liseseadmeid kasutusele võtta ainult siis, kui on kindlaks tehtud, et masin vastab masinadirektiivi 2006/42/EÜ kaitsenõuetele.

Elektromagnetilisele ühilduvusele vastav ehitus. Juhtimis- ja võrgukaablid paigaldada mootori toitekaablist ruumiliselt eraldatuna. [PES] Kaabli kaitseekraan ühendada ulatuslikult talitusmaandusega.

## hu VIGYÁZAT

Az EK irányelvek hatályossági területén a frekvenciavezérelt készülékeket és azok tartozékait csak akkor szabad üzembe helyezni, ha megállapítást nyert, hogy a gép megfelel a gépek biztonságáról szóló, 2006/42/EK számú irányelv biztonsági követelményeinek.

Elektromágnesesen összeférhető kivitelű biztosítson. A motorvezetékektől térben elkülönítve vezesse vezérlő és hálózati vezetékeket. [PES] Nagy felületen csatlakoztassa a védőföldeléshez a vezetékhétyékolást.

## lv IEVĒROT PIESARDZĪBU

Valstīs, kurās ir spēkā EK direktīvas, ierīču ar frekvenču vadību un to piederumu ekspluatāciju drīkst sākt tikai tad, ja ir konstatēta iekārtas atbilstība Mašīnu direktīvā 2006/42/EK ietvertajām aizsardzības prasībām.

EMS atbilstoša uzbūve. Vadības un tīkla kabelus izvietot atsevišķi no motora kabeļa. [PES] Vada ekrānu plašā virsmā savienot ar PE.

## lt ATSARGIAI

EB direktyvų taikymo srityje dažniniu būdu valdomus įrenginius ir jų priedus leidžiama pradėti naudoti tik tada, kai nustatoma, kad įrenginys atitinka Mašinų direktyvos 2006/42/EB keliamus apsaugos reikalavimus.

Montažas turi atitikti EMS reikalavimus. Valdymo ir duomenų tinklo kabelius išdėstyti atokiai nuo variklio kabelio. [PES] Kabelio ekraną dideliu paviršiumi sujungti su žeminiu.

## pl OSTROŻNIE

Na obszarze obowiązywania dyrektyw WE urządzenia sterowane częstotliwościowo wolno wprowadzać do eksploatacji tylko wtedy, gdy zostanie stwierdzone, że maszyna spełnia wymagania ochronne dyrektywy maszynowej 2006/42/WE.

Konstrukcja zgodna z dyrektywą w sprawie kompatybilności elektromagnetycznej (EMC). Przewody sterowania i zasilania elektrycznego należy układać oddzielnie od przewodu silnika. [PES] Ekranowanie połączyć z przewodem uziemiającym na większej powierzchni.

## sl PREVIDNO

Na območju veljavnosti direktiv ES je zagon frekvenčno krmiljenih naprav in njihovega pribora dovoljen le tedaj, ko je bilo ugotovljeno, da stroj ustreza varnostnim zahtevam Direktive o strojih 2006/42/ES.

Montaža v skladu z EMZ. Krmilne in omrežne vodnike napeljuje ločeno od vodnikov motorja. [PES] Oklep vodnika na veliki površini povežite z zaščitnim vodnikom.

## sk VÝSTRAHA

V krajinách, ktoré spadajú pod pôsobnosť smernice ES smú byť rádiovo ovládané zariadenia a ich príslušenstvo uvedené do prevádzky len ak je zabezpečené, že stroj spĺňa ochranné ustanovenia smernice č. 2006/42/ES o strojových zariadeniach.

Montáž v súlade s požiadavkami elektromagnetickej kompatibility. Ovládacie a sieťové vedenia uložte v priestore oddelene od vedenia motoru. [PES] Zabezpečte veľkú kontaktnú plochu medzi káblovým tienením a PE.

## bg ВНИМАНИЕ

В сферата на действие на изискванията на ЕС устройствата с честотно управление и техните допълнителни устройства могат да бъдат приведени в употреба, само ако се установи, че оборудването съответства на изискванията за безопасност на машинно оборудване спрямо 2006/42/EO.

Монтаж с електромагнитна съвместимост. Полагане на контролните и мрежови проводници пространствено отделно от проводника на двигателя. [PES] Осигурете по-голяма контактна площ между силовия екран и PE.

## ro PRECAUTJE

În cadrul sferei de aplicare a directivelor UE dispozitivele controlate prin frecvență și accesoriile acestora au voie să fie puse în funcțiune doar dacă se stabilește că aparatul îndeplinește cerințele Directivei 2006/42/CE privind mașinile.

Montajul trebuie să fie compatibil EMC. Poziționați cablurile de control și de rețea la distanță de cablul motorului. [PES] Asigurați o suprafață de contact mare între izolația cablului și PE.

## hr OPREZ

U području valjanosti Direktive EZ frekvencijski upravljani uređaji i njihov pribor smiju se puštati u rad samo ako se utvrdi da stroj ispunjava zahtjeve za zaštitom iz Direktive o strojevima 2006/42/EZ.

Konstrukcija u skladu s EMC-om. Upravljački i mrežni vodovi prostorno položeni odvojeno od voda motora. [PES] zaslon kabela povezan PE-om na velikoj površini.

