

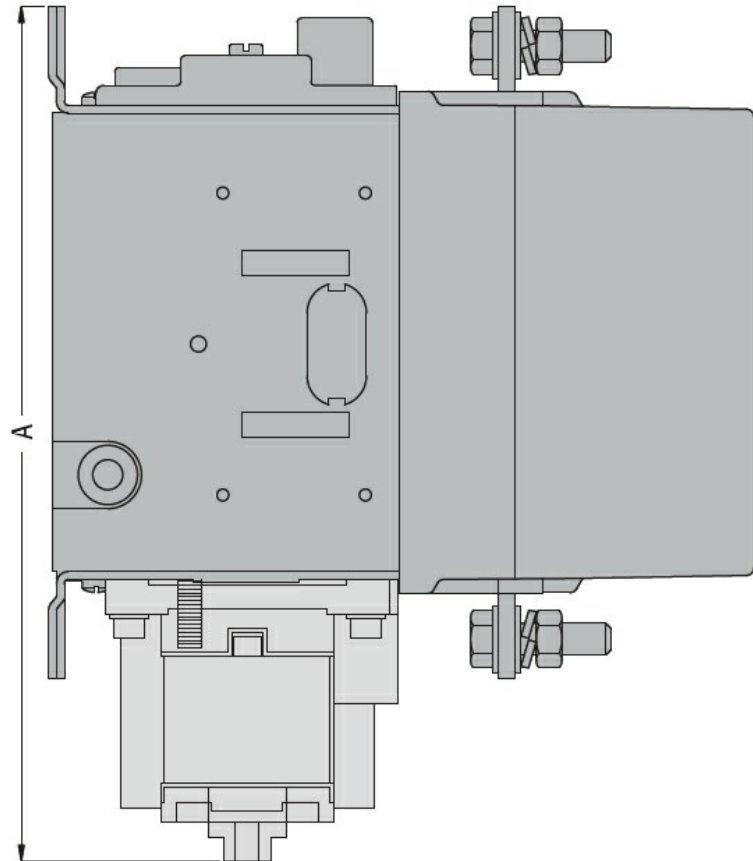

**Dimensions**

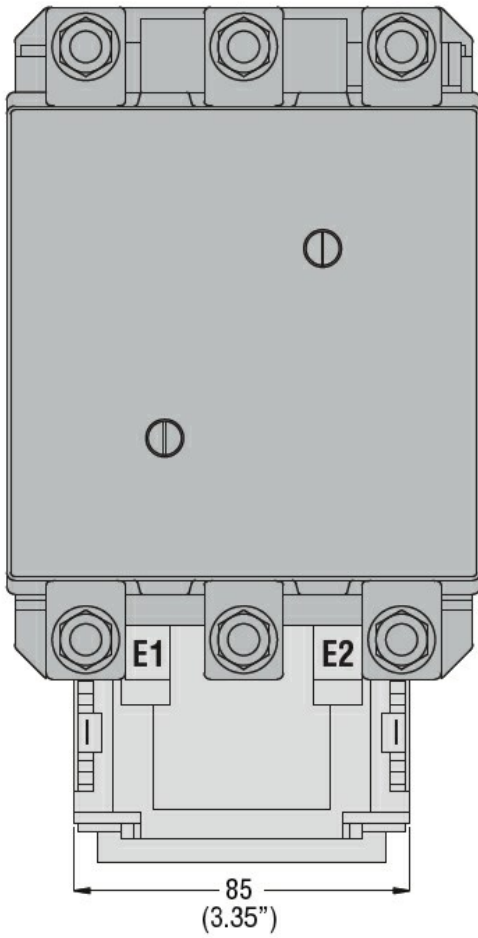

CONTACTOR TYPE	A
B115 - B145 - B180	221 (8.70")
B250 - B400	255 (8.86")
B500 - B630	300 (11.81")

**Wiring diagrams**

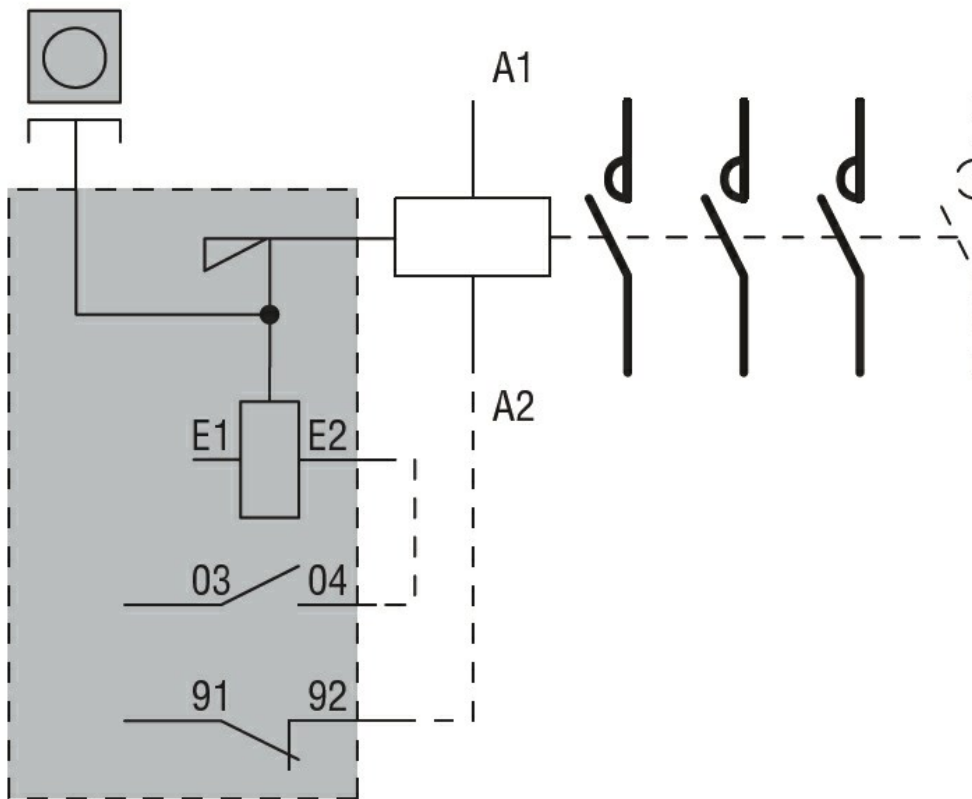

**Certifications and compliance**

Compliance

CSA C22.2 n° 60947-1

IEC/EN 60947-1

UL 60947-1

Certificates

/

**ETIM classification**

ETIM 8.0

EC002498 -  
 Accessories/spare  
 parts for low-  
 voltage switch  
 technology