

THIS COPY IS PROVIDED ON A RESTRICTED BASIS AND IS NOT TO BE USED IN ANY WAY DETRIMENTAL TO THE INTERESTS OF PANDUIT CORP.

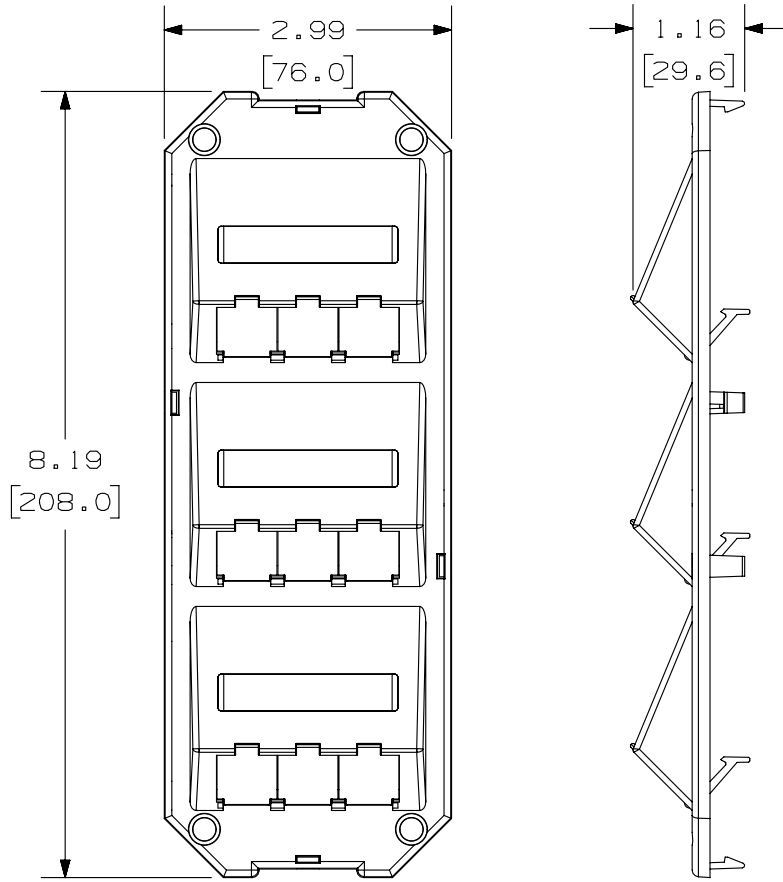

PANDUIT P/N	WEIGHT
CFPGAS9S**	1.22 LB/10 PCS (554.4 g/10 PCS)

NOTES:

- SEE CURRENT CATALOG FOR ADDITIONAL PART NUMBER SUFFIXES TO INDICATE COLOR AND OR PACKAGE QUANTITY.
- SEE CATALOG FOR COMPLETE LIST OF PARTS APPLICABLE FOR USE WITH THIS PART.
- DIMENSIONS IN PARENTHESES ARE IN METRIC.
- PART INCLUDES:
3- LABEL/LABEL COVER
1- 9 POSITION FACEPLATE
9- SHUTTER DOOR (ASSEMBLED TO FACEPLATE)
- USE WITH ACKERMANN GB3 SUB-BOX (ACKERMANN PART # 30355A OR 30355B)

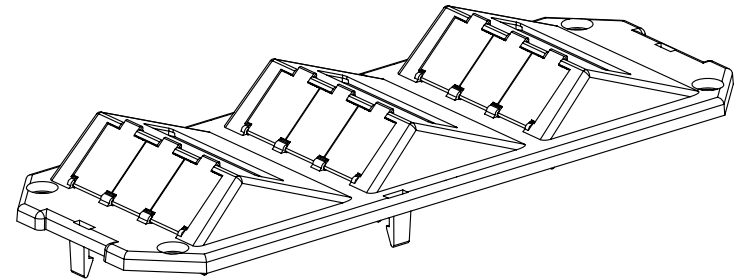

ACKERMANN IS A TRADEMARK OF NOVAR PLC, WEYBRIDGE, SURREY, UNITED KINGDOM

PART NUMBER		CFPGAS9S**	
TITLE			
MINI-COM 9 POSITION SLOPED SHUTTERED ACKERMANN FACEPLATE			
CUSTOMER DRAWING			
ITEM REVISION NAME		M02162AA/00	
DATASET FILE NAME		M02162AA_DC/00C	
UNLESS OTHERWISE SPECIFIED, DIMENSIONAL TOLERANCES ARE: IN [mm]		MATERIAL:	
.x ± .xx ± .03 [.8]		.xxx ± .010 [.3]	
ANGLES ±		DRAWING NUMBER:	
THIRD ANGLE PROJECTION		02162-02	
DRAWN BY	DATE	CHK	SCALE
JSP	2-9-05	MJD	NONE
SHT 1 OF 1			SIZE
			A

REV	DATE	BY	CHK	APR	DESCRIPTION	ECN
1	4/8/14	JSP	REFR	MMR	A. REVISED DRAWING TITLE BLOCK.	02162-02
R	2-9-05	JSP	MJD	MJD	RELEASED TO PRODUCTION	02162-02

D10100DA/14