

Panasonic

chauffage, climatisation & réfrigération

FICHE PRODUIT

U-6LE2E5

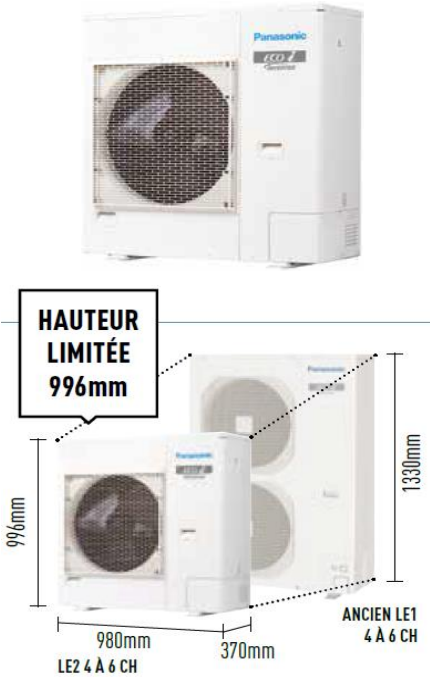

SPECIFICATIONS TECHNIQUES		
Taille		6 ch
Modèle		U-6LE2E5
Alimentation électrique		230 V 50 Hz 1 Ph
Puissance frigorifique		kW 15,5
Puissance calorifique		kW 16,5
Puissance absorbée électrique	froid	kW 4,15
	chaud	kW 3,86
EER / SEER	froid	3,73 / 7,25
	chaud	4,27 / 4,17
Débit d'air		m3/min 74
Niveau de pression sonore / Silence		dB(A) 53 / 46
Niveau de pression sonore		dB(A) 56,00
Dimensions (HxLxP)		mm 996 x 980 x 370
Poids net		kg 106
Connexion frigorifique	gaz	pouce Ø 5/8
	liquide	pouce Ø 3/8
Longueur max UE/UI		m 150
Dénivelé max UE/UI		m 50
Compresseur		type 1 (Rotatif Inverter)
Ventilateur		type kW 1 x Ventilateur hélicoïde
Quantité de fluide frigo préchargé R410 A		kg 6,7
Nombre d'unités intérieures connectables		unité 9 (12*)
Ration de capacité de connexion		% 50-130
Alimentation principale	section	mm² 6
	longueur	m 21
Intensité absorbée MAX		A 27,4
Puissance électrique absorbée MAX		Kw 5,86
Intensité au démarrage		A 1
Disjoncteur		A 32
Bus de communication		section mm² 0,75
Plage de température		longueur m 1000
froid		°C -10/+46
chaud		°C -20/+18
Pression statique externe		Pa 35

*Si la capacité de connexion de l'unité intérieure est de 1,5 kW, il est possible de connecter un maximum de 12 unités intérieures.

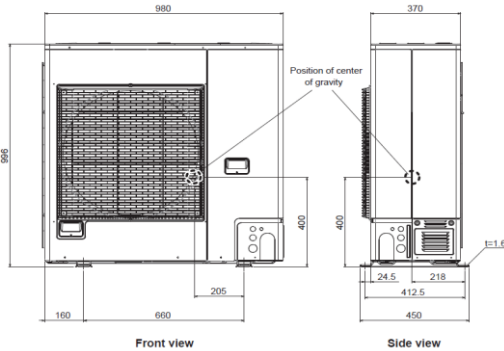
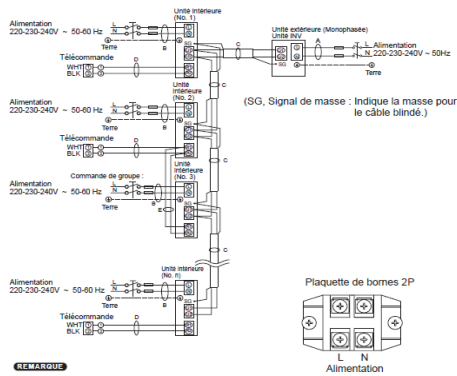

Téléchargez gratuitement les applications Datanavi et essayez-les !
Au moins deux applications pour une bonne utilisation de Datanavi.



En option