

FT03125.GRS.H96.SZ.idw.11/05/2017.10:36:39.Ajuster.A3 page

B (1:2)

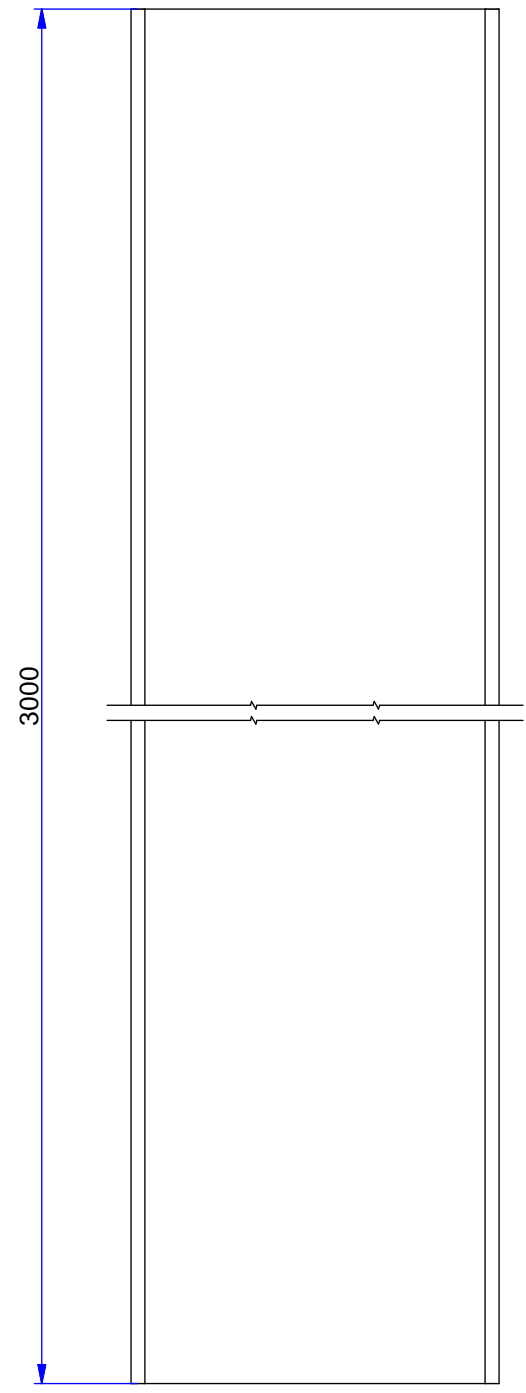
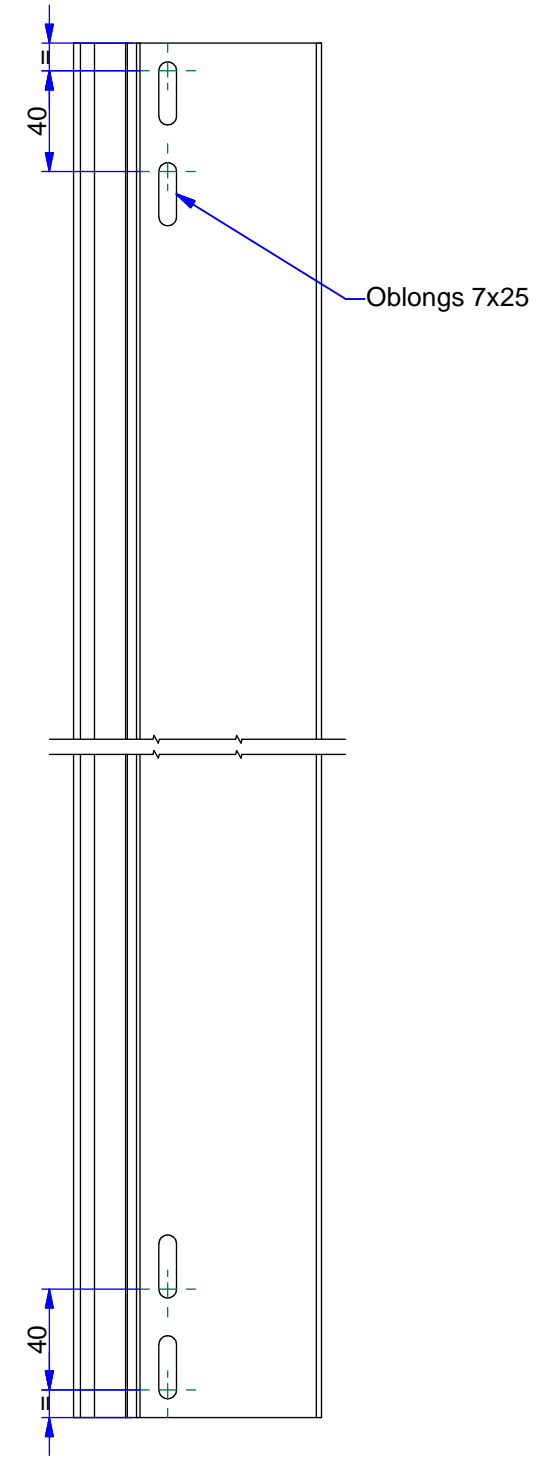
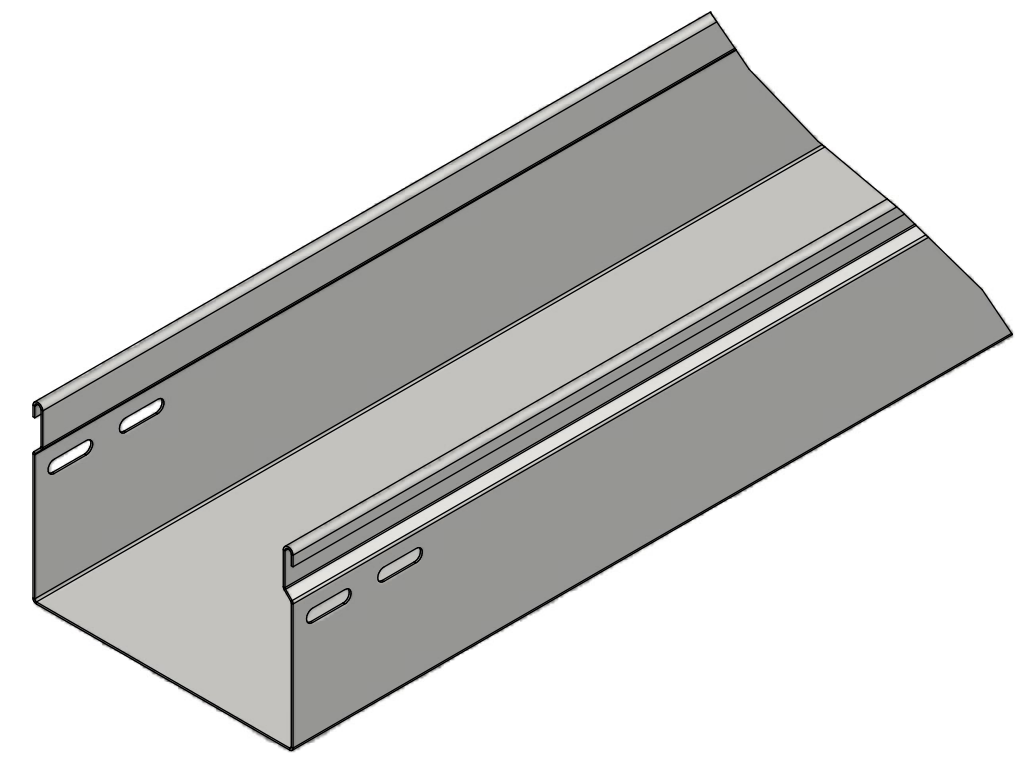
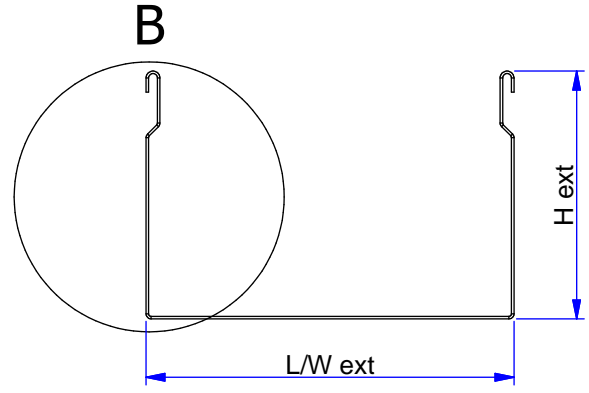
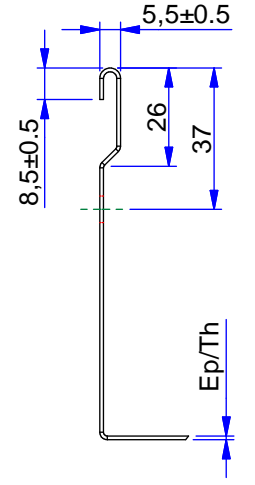

REF	DESCRIPTIONS	L/W	H	Ep/Th	Kg/m
027063	GOULOTTE GRS 96X 96	98	98	1	2,450
027064	GOULOTTE GRS 120X 96	122	98	1	2,640
027065	GOULOTTE GRS 144X 96	146	98	1	2,830
027066	GOULOTTE GRS 168X 96	170	98	1	3,010
027067	GOULOTTE GRS 192X 96	194	98	1	3,200
027068	GOULOTTE GRS 216X 96	218	98	1	3,390
027070	GOULOTTE GRS 264X 96	266	98	1	3,770
027072	GOULOTTE GRS 312X 96	314	98	1	4,150
027074	GOULOTTE GRS 360X 96	362,5	98,25	1,25	5,650
027076	GOULOTTE GRS 408X 96	410,5	98,25	1,25	6,120
027078	GOULOTTE GRS 456X 96	458,5	98,25	1,25	6,590
027080	GOULOTTE GRS 504X 96	506,5	98,25	1,25	7,070

SZ :Tôle d'acier galvanisé avant fabrication suivant NF EN 10346 (S220 GD / Z).
G : Pre-galvanised according to NF EN 10346 (S220 GD / Z).

A	CREATION	05/09/2016	B.SAVATTIER	L.LE POTIER
REV.	MODIFICATIONS	DATE	DESSINE PAR	VALIDE PAR
GOULOTTE GRS H96 SZ TRUNKING GRS H96 G				
NIEDAX France			ASSISTANCE TECHNIQUE Tél :+33 (0)1 55 95 92 17	
CE PLAN EST NOTRE PROPRIETE : IL NE PEUT ETRE NI REPRODUIT NI COMMUNIQUE SANS NOTRE AUTORISATION ECRITE PREALABLE				Révision
A3	PLAN N° : FT03125 GRS H96 SZ			A

Validé