

Push-in Mounts (Cradle Mounts)

The push-in “cradle” mounts provide an excellent wire management solution, especially suited for managing battery power cables sized 2 AWG (35mm²) up to 2/0 (70mm²) affixed in an array over a bracket, frame, or other structure. This mount pushes into and retains in a cutout to seat the mount. Offered as a pre-configured version that includes a cable tie or stand-alone version that would then be paired with the cable tie of choice.

Applications: Electric Vehicles.



Key Features and Benefits

Stepped Latches:	Allows mount to snap into varying frame thickness of 0.08” to 0.12” (2mm – 3mm)
Cradle design:	Provides secured nesting surface for cables
Raised Mounting Surface:	Cradle area is substantially raised above the surface of the frame the mount is attached to thus keeping cables from coming into contact with the metal and protecting the cable from damage
Preconfigured Version:	Comes equipped with a PLT2S cable tie so saves time that would otherwise require an installer to add a tie; fold ends of tie up to pull mount through pocket

Technical Information

Material:	Material: Impact Modified, Heat Stabilized, Weather Resistant Nylon 6.6
Continuous use temperature:	-60°C to 115°C; -76°F to 239°F
UL 94 Flammability rating:	HB
Installation Specification:	Mount is designed to seat in a user supplied frame or bracket, .08” - .12” (2mm – 3mm) thick with a cutout sized 0.94” x 0.60” (23.8mm x 15.3mm)
Compatibility:	Compatible with cable ties cross-section — Miniature, Intermediate, Standard, and Light Heavy
Cradle geometry:	Cradle geometry for nestling cable is optimally sized to accommodate 2 AWG (35mm ²) to 2/0 (70mm ²) battery cable. Recommended bundle diameter range for wire bundles: 0.31” to 0.63” (7.8mm to 16mm).

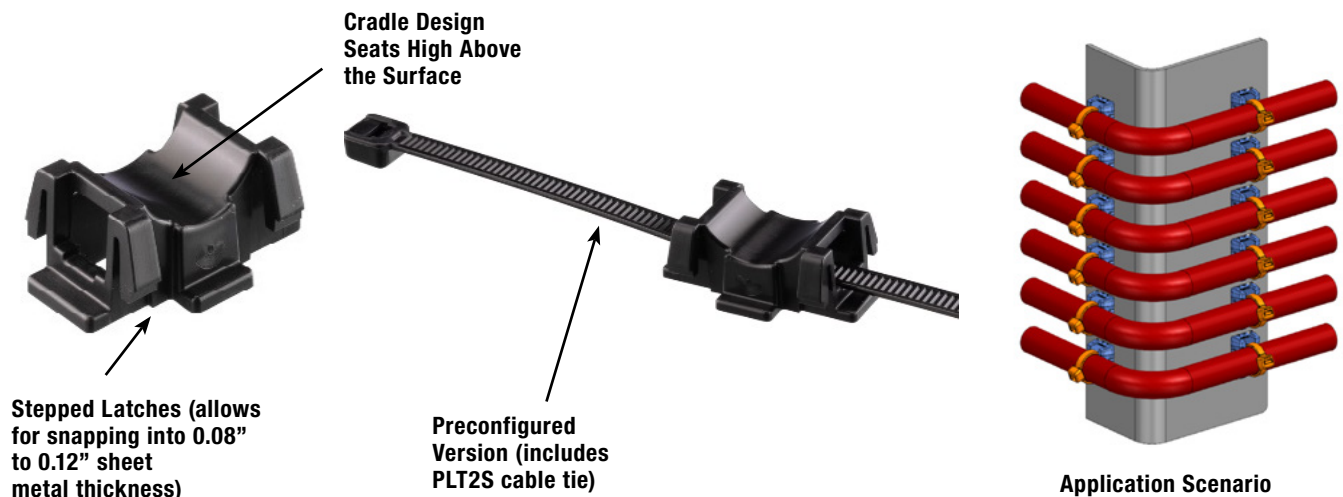

For more information visit:
www.panduit.com

Push-in Cradle Mount

Ordering Information

Mounts can be purchased with or without the cable tie included. If purchasing just the mount, it is compatible with any M, I, S, and LH cross-section cable ties. The version that includes the cable tie already added comes equipped with a PLT2S cable tie. This mount requires a user-supplied bracket or frame [0.08" – 0.12" (2mm – 3mm) thickness] with a cutout to allow the push-in mount to seat in.

Dimensions of the cutout are as follows:

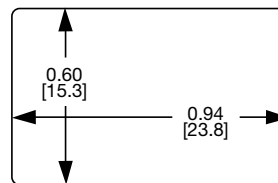

Part Number	Description	Compatible (or included) Cable Tie	Package Qty.	Carton Qty.
TCM1X63-D350	Push-in Cradle Mount	Compatible with M, I, S, LH cross-section cable ties	500	5000
TCM1X63-2S-D350	Push-in Mount and Cable Tie Assembly	Includes PLT2S-300 cable tie	500	4000

Dimensions are in inches. [Dimensions in brackets are metric].

WORLDWIDE SUBSIDIARIES AND SALES OFFICES

PANDUIT US/CANADA
Phone: 800.777.3300

PANDUIT EUROPE LTD.
London, UK
Phone: 44.20.8601.7200

PANDUIT SINGAPORE PTE. LTD.
Republic of Singapore
Phone: 65.6305.7575

PANDUIT JAPAN
Tokyo, Japan
Phone: 81.3.6863.6000

PANDUIT LATIN AMERICA
Guadalajara, Mexico
Phone: 52.33.3777.6000

PANDUIT AUSTRALIA PTY. LTD.
Victoria, Australia
Phone: 61.3.9794.9020

For a copy of Panduit product warranties, log on to www.panduit.com/warranty



For more information
Visit us at www.panduit.com
Contact Customer Service by email: cs@panduit.com
or by phone: 800.777.3300

© 2023 Panduit Corp.
ALL RIGHTS RESERVED.
FRCB17-SA-ENG
7/2023