

PANDUIT *NET-ACCESS S-Type Network Cabinets*

(Vertical Blanking Panels - S6VBPN, S7VBPN, S8VBPN)

INSTRUCTIONS V00029AD Rev. 02

© Panduit Corp. 2013, 2014

Vertical Blanking Panels (*Upper Panel Installation*)

- Install Flap Seals on top edges of Upper Blanking Panels
- Install Left-side and Right-side Upper Blanking Panels to the backside of the front adjustable Equipment Rails.

NOTES

- Some views in this document may vary slightly from your actual cabinet configuration.
- Rear equipment rails have been removed from some views to add clarity

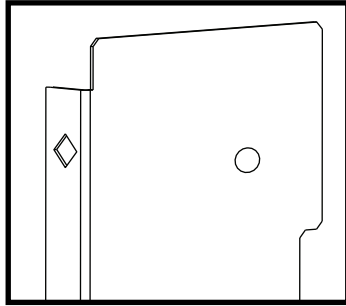

ALL LEFT-SIDE
COMPONENTS ARE
INDICATED BY A
DIAMOND CUTOUT

Upper Blanking Panel - LEFT
(note diamond cutout)

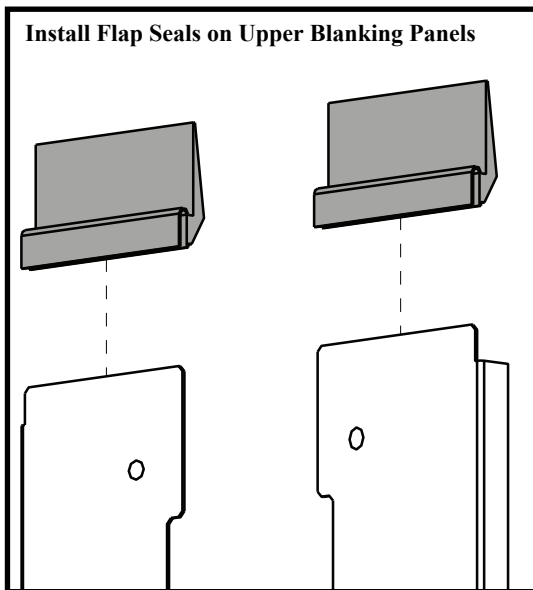

Install Flap Seals on Upper Blanking Panels

Upper Blanking Panel - RIGHT

Tool List:

- T25 Torx bit
- Utility Knife

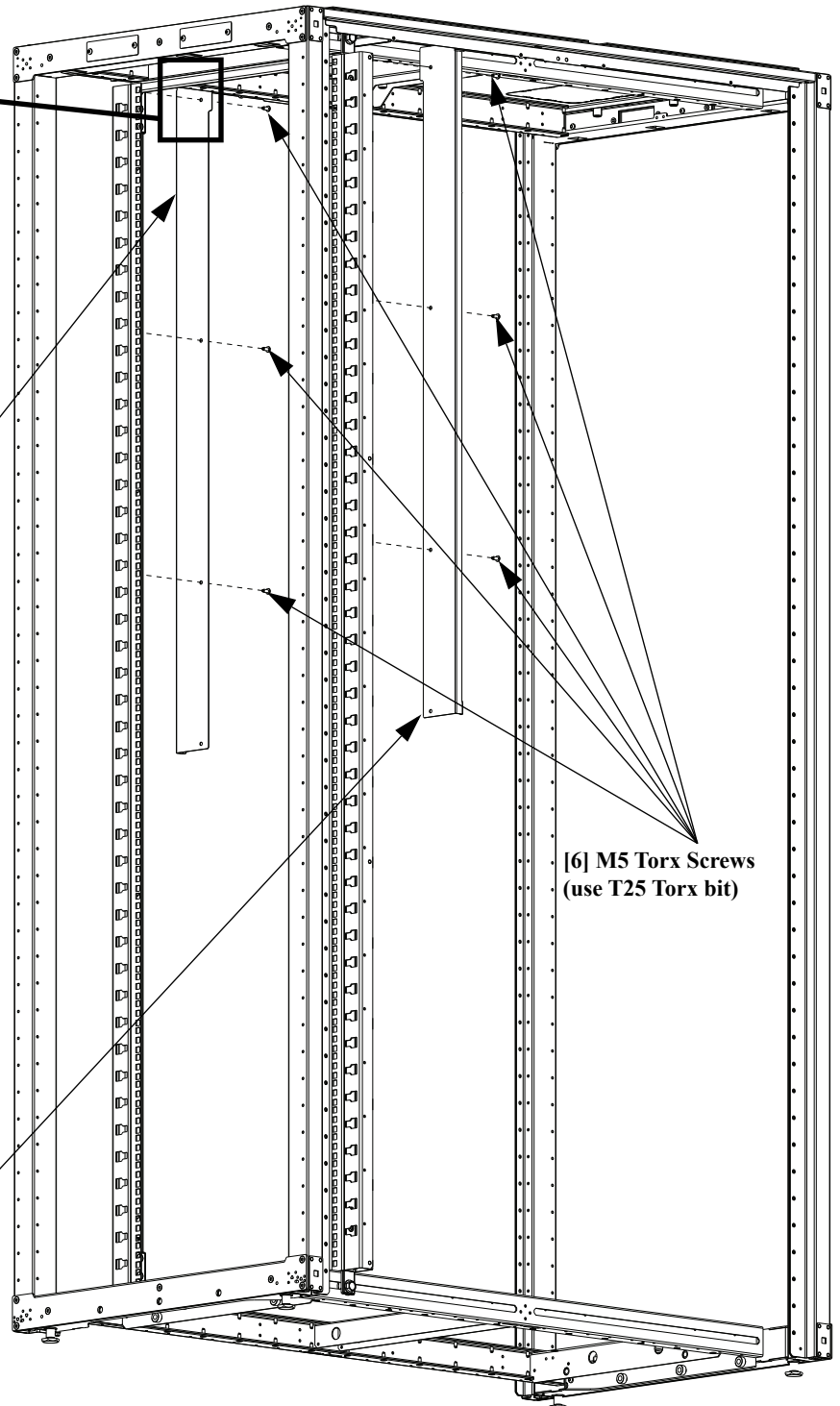

[6] M5 Torx Screws
(use T25 Torx bit)

FOR TECHNICAL SUPPORT www.panduit.com/resources/install_maintain.asp

Vertical Blanking Panels (*Lower Panel Installation*)

- Install Left-side and Right-side Lower Blanking Panels
- Ensure that Lower Panels overlap Upper Panels

Lower Blanking Panel - LEFT
(note diamond cutout)

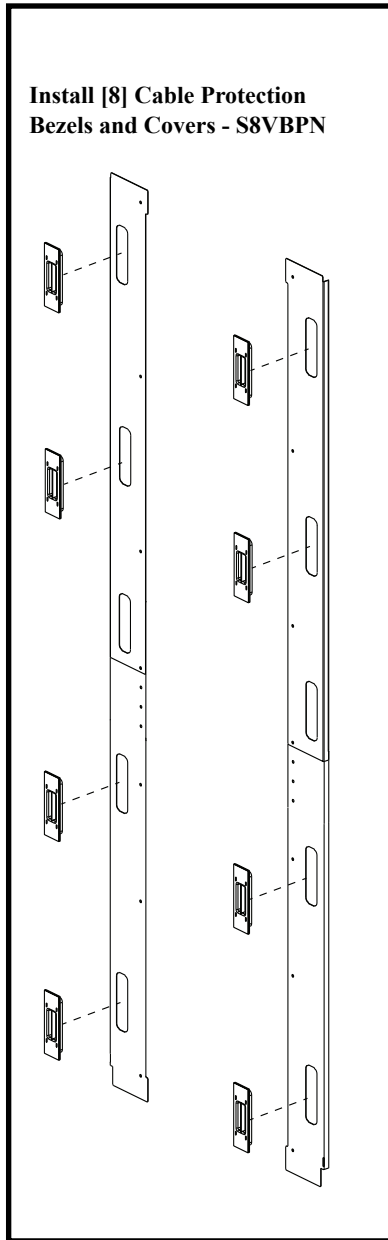

Note: [2] Additional Cable Protection
Bezels, CTCN1X5, to be purchased
separately when S8VBPN is
expanded to 51RU

Lower Blanking Panel - RIGHT

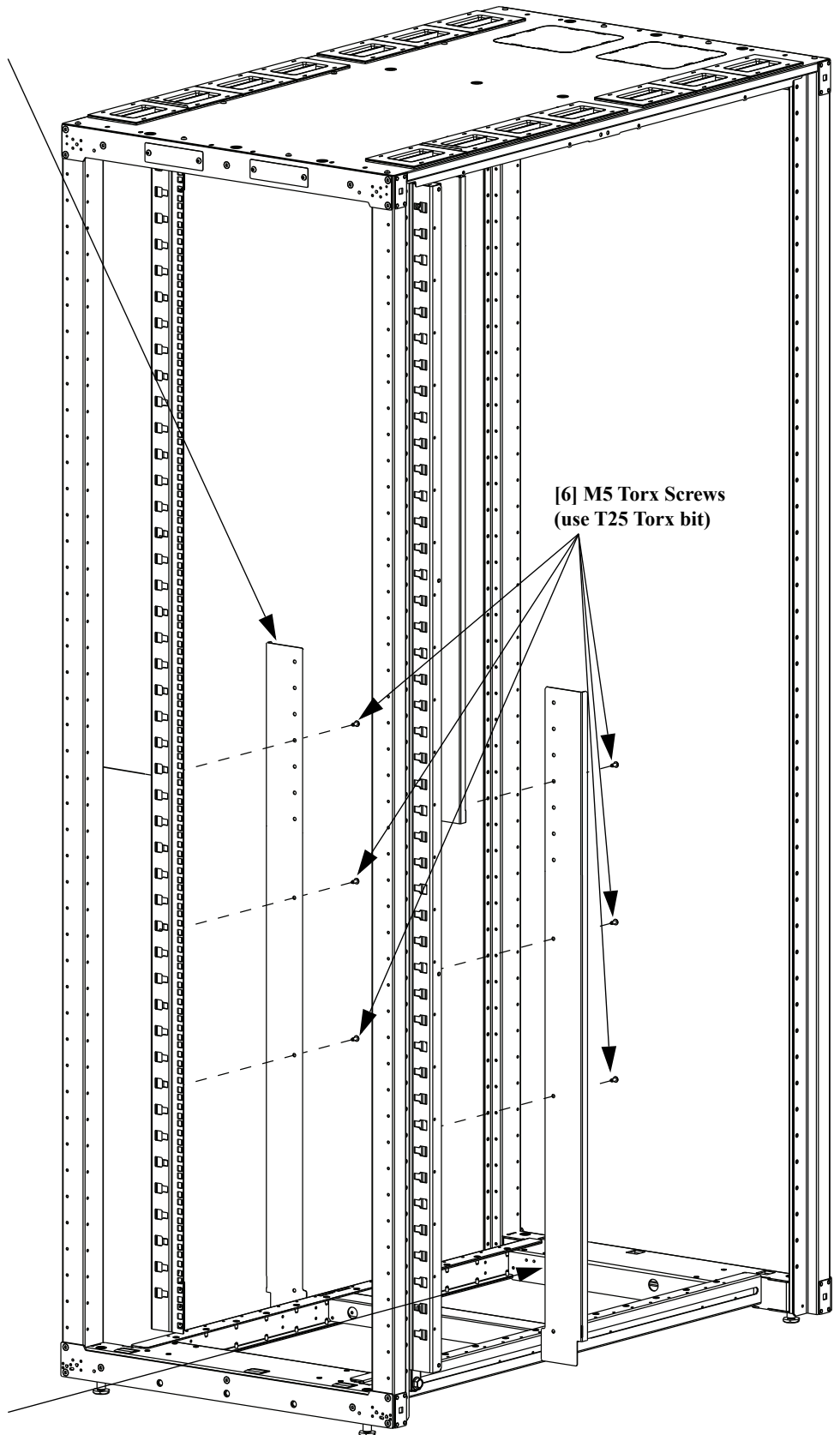

[6] M5 Torx Screws
(use T25 Torx bit)

Horizontal Blanking Panels (*Flap Seal and Screw Installation*)

- Install [2] Flap Seal sections onto edges of Top and Bottom Horizontal Blanking Panels
- Insert [3] M5 Torx Screws into each Horizontal Blanking Panel

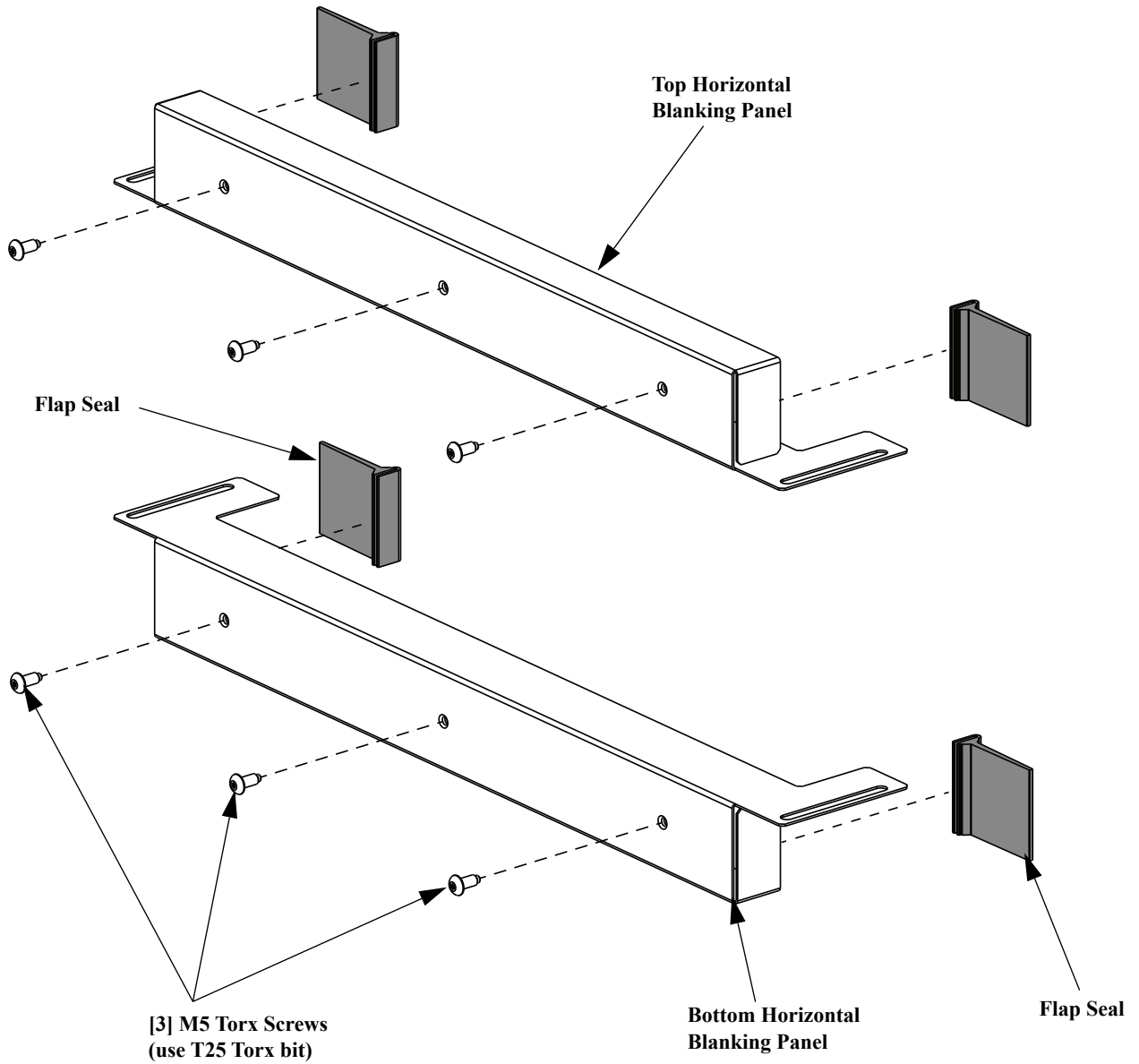

Vertical Blanking Panels (*Top Seals*)

- Align front face of Horizontal Blanking Panel with Equipment Rails and install to the top front to back beams using [2] M5 torx screws.
- Attach D-shaped Rubber Seal to Horizontal Blanking Panel
- Ensure that Flap Seals are positioned tight against top of cabinet.

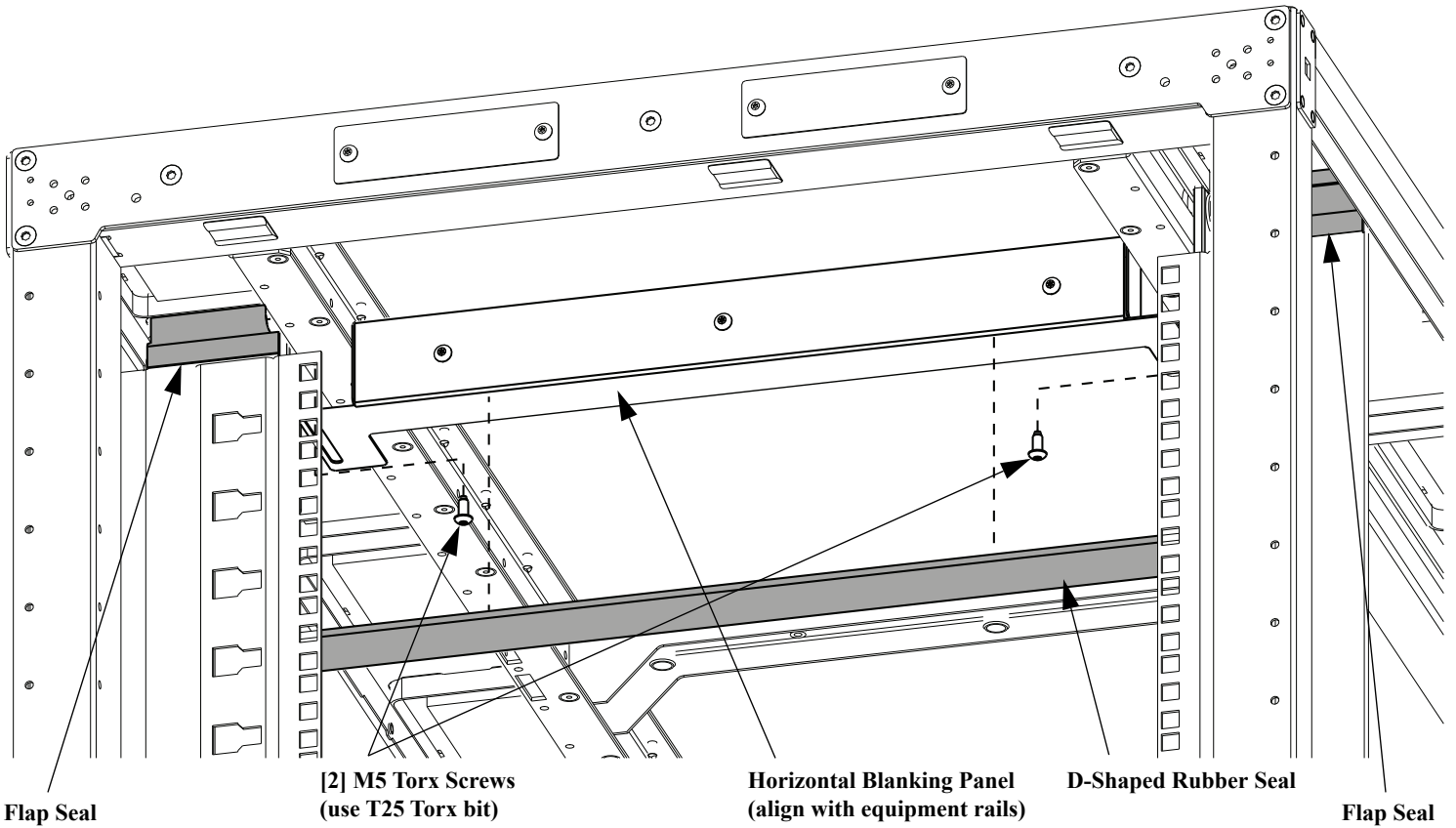

Top Blanking Panel (*Integral Cabinet Top Cable Routing System - ONLY*)

- Adjust width of Top Blanking Panel (if necessary, for 800mm wide cabinets --- use 8mm wrench to adjust nuts)
- Apply Adhesive Seal to top edge of Top Blanking Panel (cut to length for 600mm and 700mm wide cabinets)
- Loosen [3] screws on front face of Hori-

Adhesive Seal (cut to length)

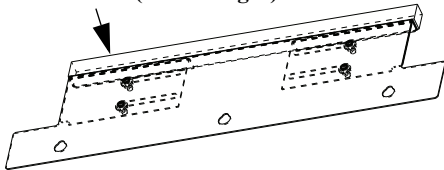

Top Blanking Panel - 600/700mm

Adhesive Seal

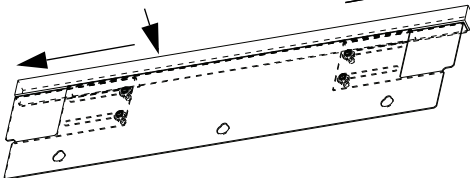

Top Blanking Panel - 800mm

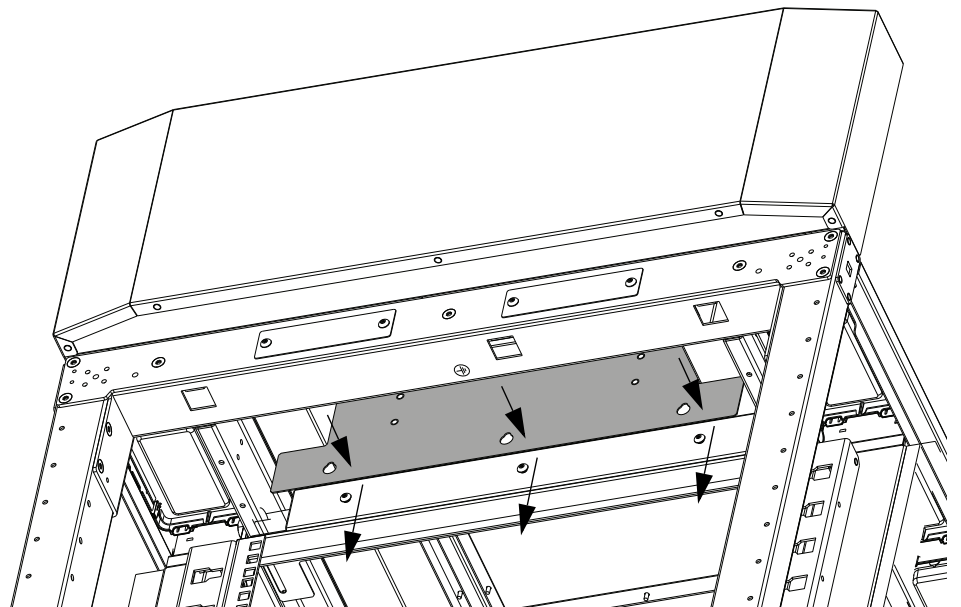

Vertical Blanking Panels (*Side Seals*)

- Attach 3/8" Bulb Seals to vertical edges of Blanking Panels by sliding Seal channel over Blanking Panel flange. - Trim Seal length if necessary

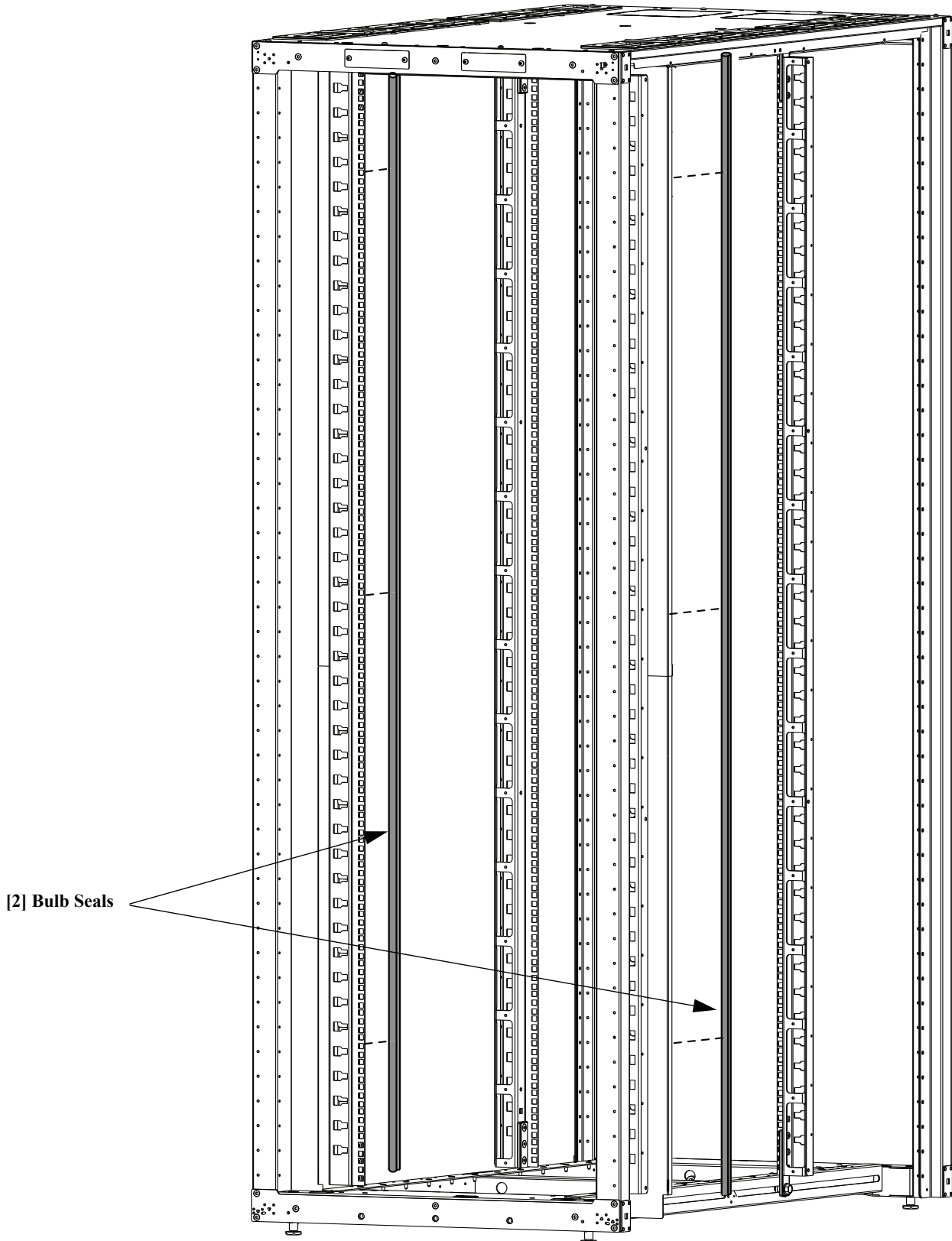

Vertical Blanking Panels (*Floor Seals*)

- Align front face of Horizontal Blanking Panel with Equipment Rails and install to the lower front to back beams using [2] M5 Torx screws.
- Install [2] Bottom Seal Brackets (Left Bracket is noted by diamond cutout) using [2] M5 Torx Screws
- Attach D-shaped Rubber Seal to Horizontal Blanking Panel.
- Attach 25mm x 50mm Foam Seals to bottoms of Horizontal Blanking Panel and [2] Bottom Seal Brackets
- Attach 13mm x 25mm Foam Seals to outer edge of [2] Bottom Seal Brackets.

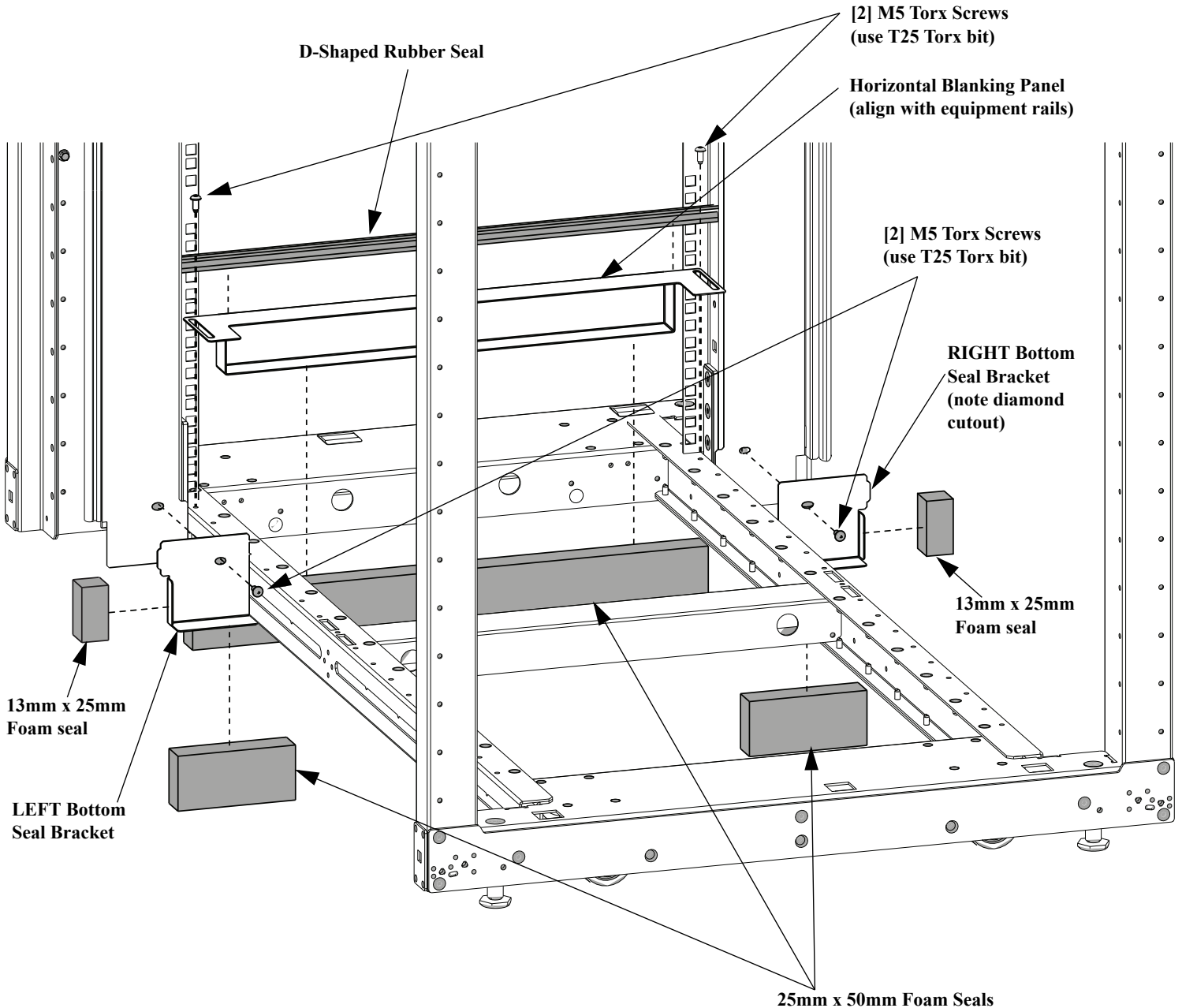

Cabinet to Cabinet Seal

- Align Between Cabinet Bracket so the front face overlaps the front face of the Blanking panels.
- While holding Between Cabinet Bracket, attach Seal Cover to the Between Cabinet Bracket using M5 Torx Screw.
- Attach 25mm x 50mm Foam Seal to the bottom of the Seal Cover.

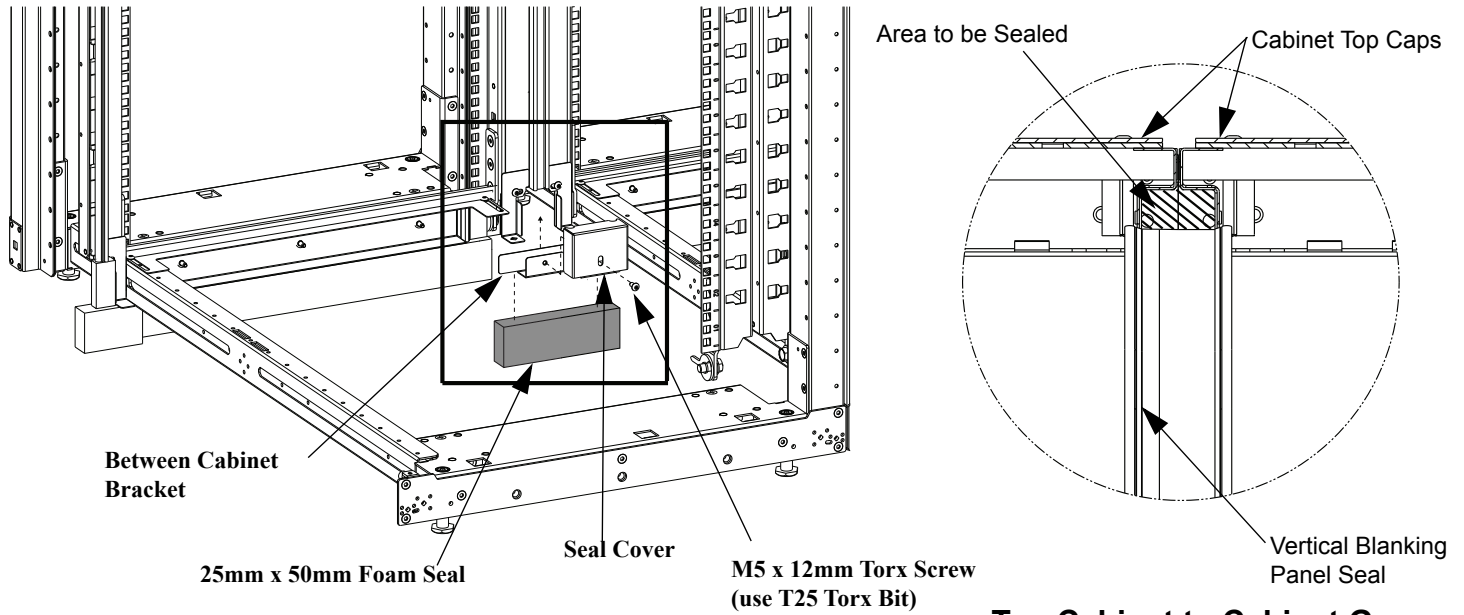

Top Cabinet to Cabinet Gap Sealing Installation

-Air Gap between top cap and Blanking Panels should be sealed with Blanking Foam Seal

Step 1:

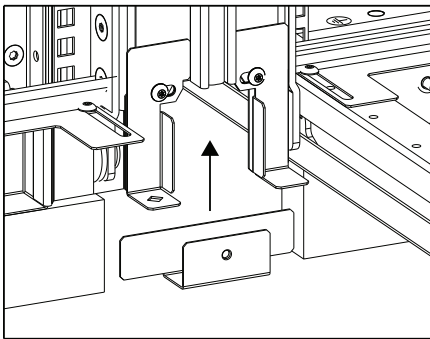

Step 2:

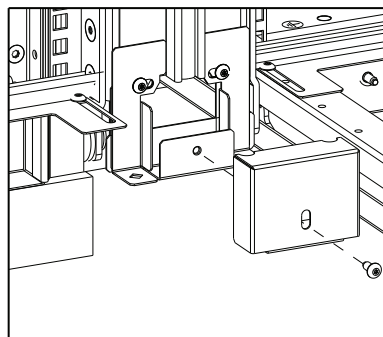

Step 3:

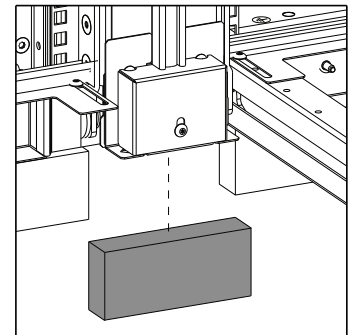

For Instructions in Local Languages
and Technical Support:

www.panduit.com/resources/install_maintain.asp

PANDUIT
www.panduit.com

E-mail:
techsupport@panduit.com
Phone:
866-405-6654