

2

1

THIS COPY IS PROVIDED ON A RESTRICTED BASIS AND IS NOT TO BE USED IN ANY WAY DETRIMENTAL TO THE INTERESTS OF PANDUIT CORP.

PANDUIT P/N	WEIGHT
CFP86S2**Y	.62 LB/10 PCS (280.4 g/10 PCS)

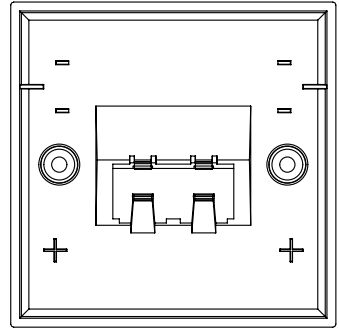
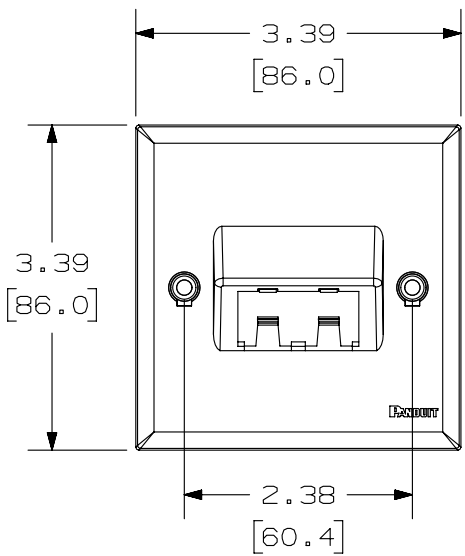

- NOTES:
- SEE CURRENT CATALOG FOR ADDITIONAL PART NUMBER SUFFIXES TO INDICATE COLOR AND OR PACKAGE QUANTITY.
 - SEE CATALOG FOR COMPLETE LIST OF PARTS APPLICABLE FOR USE WITH THIS PART.
 - DIMENSIONS IN [] ARE IN METRIC.
 - PART INCLUDES:
 - 1- FACEPLATE
 - 2- M3.5 X 30mm MOUNTING SCREWS
 - 2- SCREW CAPS

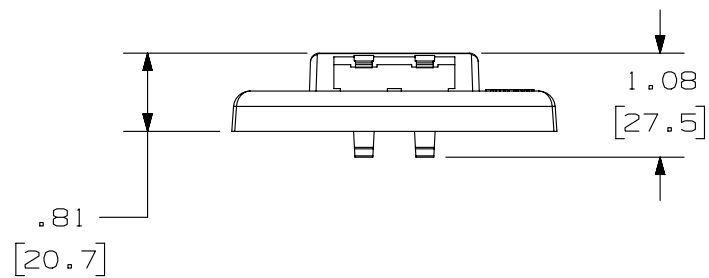
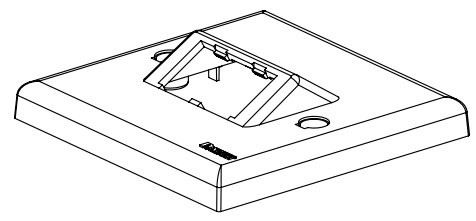

PART NUMBER		CFP86S2*Y	
TITLE			
MINI-COM 2 POSITION SLOPED 86MM X 86MM FACEPLATE CUSTOMER DRAWING			
ITEM REVISION NAME		M02479GC/00	
DATASET FILE NAME		M02479GC_DC161/00B	
UNLESS OTHERWISE SPECIFIED, DIMENSIONAL TOLERANCES ARE: IN [mm]		MATERIAL:	
.x ± .1 [.254] .xx ± .01 [.25]		ABS	
.xxx ± .005 [.127] ANGLES ± 5 °		DRAWING NUMBER:	
THIRD ANGLE PROJECTION		02479-161	
DRAWN BY	DATE	CHK	SCALE
JSP	4-18-06	REFR	NONE
SHT 1 OF 1			SIZE
			A

REV	DATE	BY	CHK	APR	DESCRIPTION	ECN
1	2-26-14	MDJR	REFR	MMR	B. REVISED NOTE 4. A. UPDATED TITLE BLOCK.	02479-161
R	4-18-06	JSP			RELEASED TO PRODUCTION	02479-161

2

1

D10100DA/14