

Low Voltage
User Manual | 01/2017

Micrologic

Control units
5.0 P, 6.0 P and 7.0 P



Discovering Micrologic P	4
Identification	4
Presentation	5
Setting procedure	6
Setting Micrologic 5.0 P using the dials	8
Setting Micrologic 6.0 P using the dials	9
Setting Micrologic 7.0 P using the dials	10
Selecting the type of neutral protection	11
Main menus	12
Metering	14
History, maintenance and setup	16
Protection	18
Overview of functions	20
Current protection	20
Voltage protection	27
Other protection	28
Load shedding and reconnection	29
Measurements	30
Alarms	32
Event histories	33
LEDs and display screens	34
Communication	36
Optional M2C and M6C contacts	38
Setup	40
Setting up the optional M2C / M6C contacts	40
Setting up the Micrologic control unit	42
Setting up the metering functions	45
Setting up the COM communications option	48
Protection settings	52
Fine adjustment of the long-time I^2t , short-time and instantaneous settings using the keypad	52
Fine adjustment of the long-time I_{dmtl} , short-time and instantaneous settings using the keypad	53
Fine adjustment of the ground-fault and earth-leakage protection setting using the keypad	54
Setting the neutral protection	55
Setting the I_{\pm} , I_{unbal} , T_{max} , U_{min} , U_{max} , U_{unbal} , rP_{max} , F_{min} , F_{max} , and phase-rotation protection functions using the keypad	56
Setting load shedding / reconnection	58
Metering	60
Current measurements	60
Voltage measurements	63
Power measurements	65
Energy measurements	67
Frequency measurements	68
Maintenance	70
Resetting fault indications	70
Viewing the event histories	71
Operation counter and contact-wear indicator	72
Checking/replacing the battery	73
Tests	74

Technical appendix	76
Tripping curves	76
Voltage measurements	78
Zone selective interlocking (ZSI)	80
Power supply	81
Changing the long-time rating plug	83
Thermal memory	84
Data available via the COM communications option	85
Threshold and time-delay settings	86
Other settings	89
Measurement setting ranges and accuracy	90
Power factor sign conventions	91
Index	92



All Masterpact NT and NW circuit breakers are equipped with a Micrologic control unit that can be changed on site. Control units are designed to protect power circuits and connected loads. They offer current, voltage, frequency, power and energy measurements. The functions provided by Micrologic 5.0 P, 6.0 P and 7.0 P control units optimise continuity of service and power management in your installation.

Micrologic 5.0 P

Selective protection + Idmtl, power measurements and additional protection

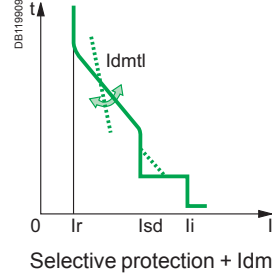

Micrologic 5.0 P



- X: type of protection
- 2 for basic protection
 - 5 for selective protection
 - 6 for selective + ground-fault protection
 - 7 for selective + earth-leakage protection

Y: version number
 Identification of the control-unit generation:
 "0" signifies the first generation.

- Z: type of measurement
- A for "ammeter"
 - E for "energy meter"
 - P for "power meter"
 - H for "harmonic meter"
 - no indication = no measurements

Micrologic 6.0 P

Selective protection + Idmtl + ground-fault protection, power measurements and additional protection

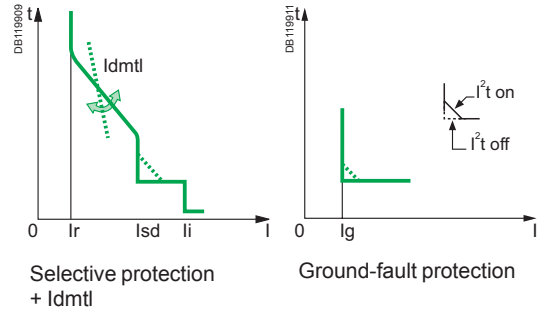

Micrologic 7.0 P

Selective protection + Idmtl + earth-leakage protection, power measurements and additional protection

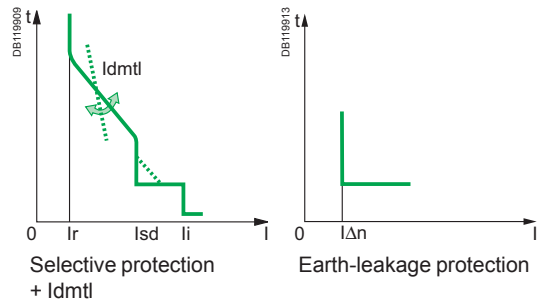

- 1 top fastener
- 2 terminal block for external connections
- 3 housing for battery
- 4 screw for long-time rating plug
- 5 long-time rating plug
- 6 cover opening point
- 7 protective cover
- 8 lead-seal fixture for protective cover
- 9 infrared link with communications interfaces
- 10 connection with circuit breaker
- 11 bottom fastener

Indications

- 12 LED indicating long-time tripping
- 13 LED indicating short-time or instantaneous tripping
- 14 LED indicating ground-fault or earth-leakage tripping
- 15 LED indicating additional-protection or auto-protection tripping
- 16 graphics display
- 17 button for reset of fault-trip LED reset and battery test

Navigation

- 18 access button to the "Metering" menu (1)
- 19 access button to the "History, maintenance and setup" menu (1)
- 20 access button to the "Protection" menu (1)
- 21 button used to scroll down or reduce the displayed value
- 22 button used to scroll up or increase the displayed value
- 23 button used to select or confirm a choice

Adjustment dials

- 24 long-time current setting Ir
- 25 long-time tripping delay tr
- 26 short-time pickup Isd
- 27 short-time tripping delay tsd
- 28 instantaneous pickup Ii
- 29 ground-fault pickup Ig
- 30 ground-fault tripping delay tg
- 31 earth-leakage pickup IΔn
- 32 earth-leakage tripping delay Δt
- 33 LED indicating an overload
- 34 test button for ground-fault and earth-leakage protection
- 35 test connector

(1) These buttons include a LED indicating the active menu.

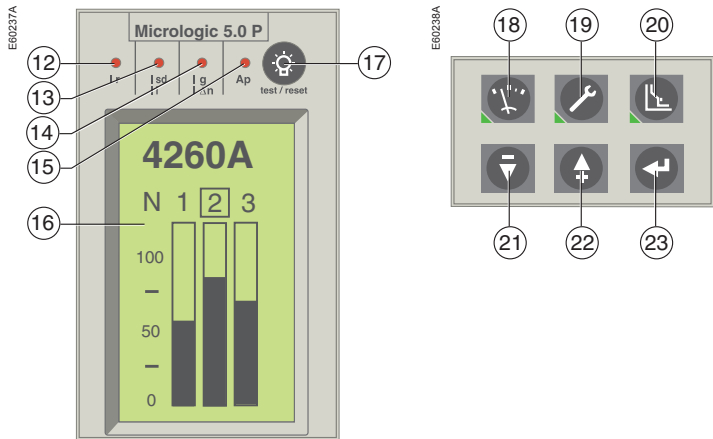
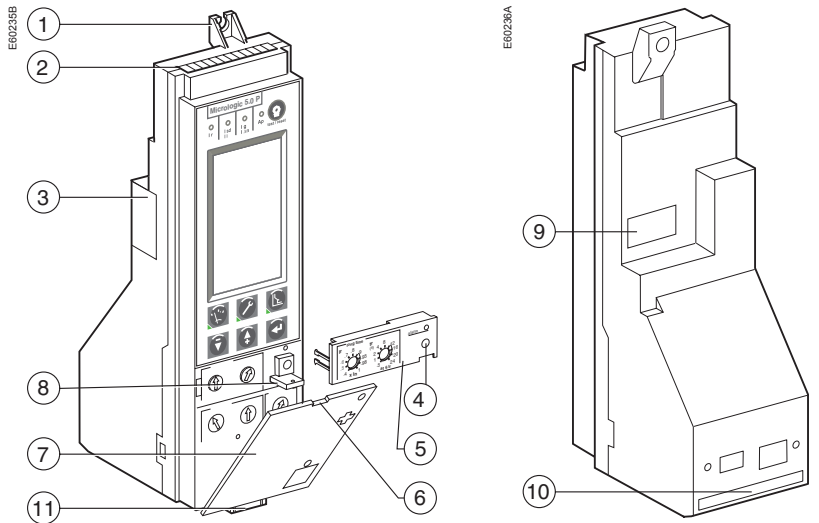

Micrologic 5.0 P control unit

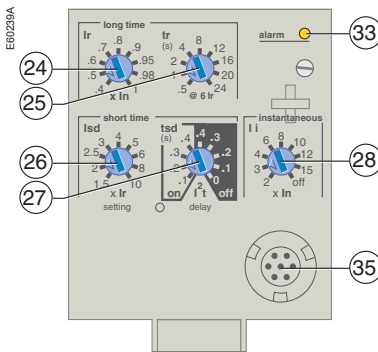

Micrologic 6.0 P control unit

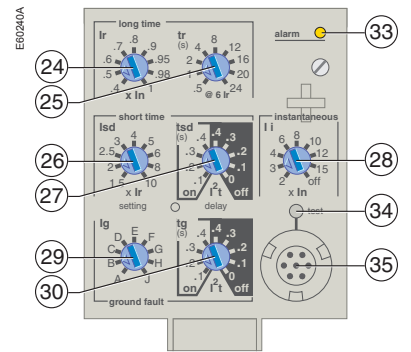

Micrologic 7.0 P control unit

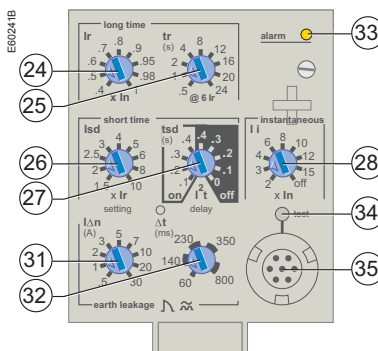

Dials

- Dials are used to set Micrologic P protection thresholds and tripping delays for overloads, short-circuits, ground faults and earth leakage.
- If the set thresholds are overrun, these protection functions systematically trip the circuit breaker.

Settings using the dials

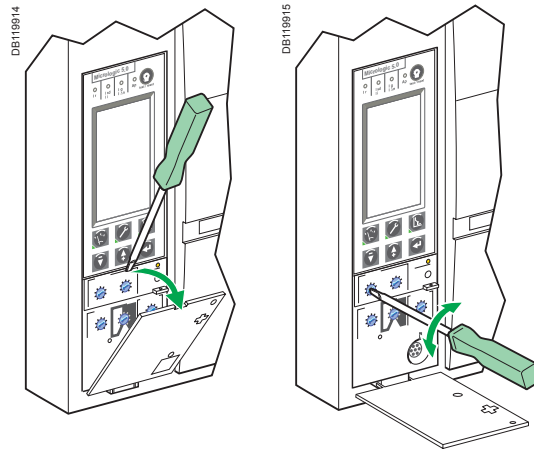



- Open the protective cover.
- Make the necessary settings using the dials
- The screen automatically displays the relevant curve
- Check the set value on the screen, in absolute value in amperes (A) and in seconds (s).

Buttons

- Buttons on the keypad are used for fine adjustments of the protection thresholds and tripping delays for overloads, short-circuits, ground faults and earth leakage. The value previously set using a dial automatically becomes the maximum value for the keypad settings.
- They may also be used to activate other factory-disabled protection functions available on Micrologic P. These other protection functions are not accessible via the dials.

Settings using the keypad

- The  and  buttons under the screen may be used for fine adjustments of the settings made using the dials.
- All the settings not available via the dials are made in the same manner, using the keypad.

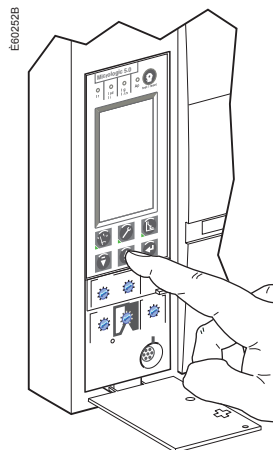

With the protective cover open, make all the necessary settings for your control unit.

All fine adjustments are permanently stored in memory, unless the setting is modified using the adjustment dial.

For remote settings using the communications option, see the "Remote settings" section in the "Com setup" menu under "History, maintenance and setup".

Important

A new overload (long-time) or short-circuit (short-time and instantaneous) protection setting made using one of the dials:

- deletes all the fine adjustments previously made using the keypad for the overload (long-time) and short-circuit (short-time and instantaneous) protection
- does not affect the fine adjustments made using the keypad for ground-fault and earth-leakage protection
- does not affect any other settings made using the keypad.

Similarly, a new ground-fault or earth-leakage protection setting made using one of the dials:

- deletes all the fine adjustments previously made using the keypad for the ground-fault and earth-leakage protection
- does not affect the fine adjustments made using the keypad for the overload (long-time) and short-circuit (short-time and instantaneous) protection
- does not affect any other settings made using the keypad.

With the protective cover closed, it is not possible to set the protection functions. However, it is possible to set metering functions and alarms, as well as view all measurements, settings and histories.

View the settings and measurements

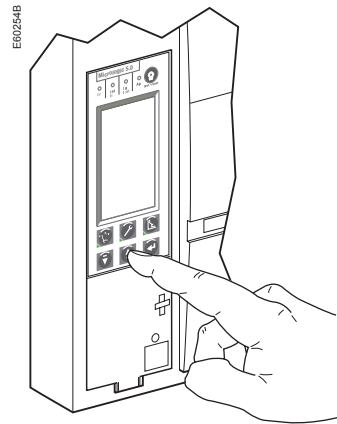
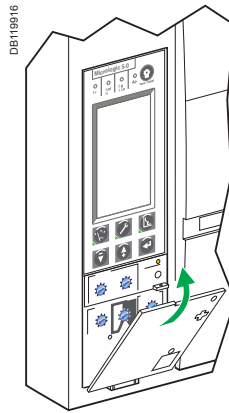

- Close the protective cover for the dials
- Access to the dials is blocked and it is no longer possible to make fine adjustments using the keypad

- If necessary, install a lead seal to protect the settings
- Settings may be viewed at any time using the keypad.

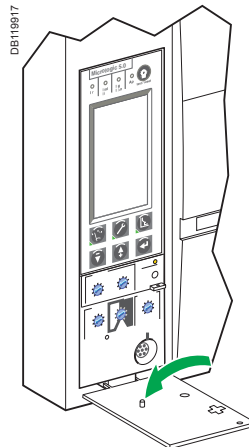

Important

If you notice that the tab on the back of the protective cover has been broken off, contact the Schneider Electric after-sales support department to replace the cover.

Setting Micrologic 5.0 P using the dials

Consider a 2000 A circuit breaker.

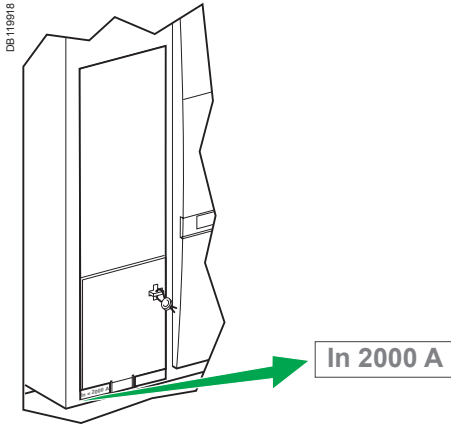

Set the thresholds

DB119919

In = 2000 A

$I_r = 0.5 \times 2000 = 1000 \text{ A}$

$I_{sd} = 2 \times 1000 = 2000 \text{ A}$

$I_i = 2 \times 2000 = 4000 \text{ A}$

See pages 22 and 24 for selection of the setting ranges.

Set the time delays

DB119910

tr = 1 s

tsd = 0.2 s

Thresholds

I²t ON curve

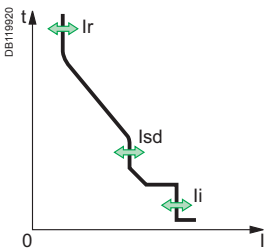

I²t OFF curve

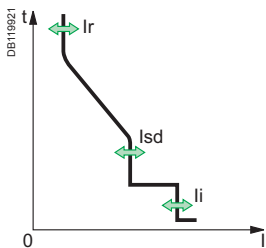

Time delays

I²t ON curve

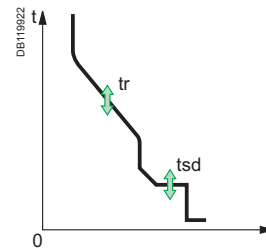

I²t OFF curve

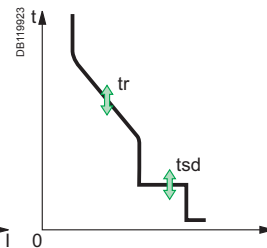

Ir: LT threshold
Isd: ST pickup
Ii: Instantaneous pickup

tr: LT tripping delay
tsd: ST tripping delay

Consider a 2000 A circuit breaker.

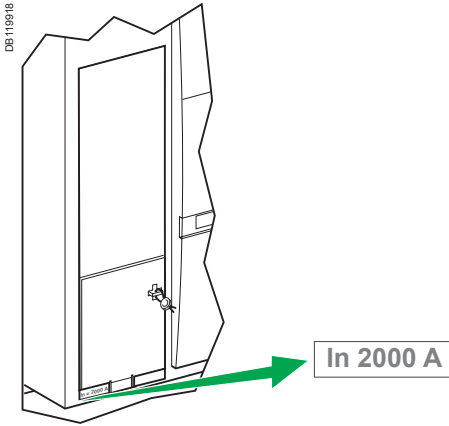

Set the thresholds

DB119924

long time
Ir
0.4 0.5 0.6 0.7 0.8 0.9 0.95 1 1.08 1.15
x In

short time
Isd
1.5 2 2.5 3 4 5 6 8 10
x Ir
setting

instantaneous
Ii
2 3 4 6 8 10 12 15 20
x In

Ig
A B C D E F G H J

ground fault

In = 2000 A

Ir = 0.5 x 2000 = 1000 A

Isd = 2 x 1000 = 2000 A

Ii = 2 x 2000 = 4000 A

B → Ig = 640 A

See pages 22 to 26 for selection of the setting ranges.

Set the time delays

DB119925

long time
tr (s)
0.5 1 2 4 8 12 16 20 24
@ 6 Ir

short time
tsd (s)
0.1 0.2 0.3 0.4
on I t off
delay

tg (s)
0.1 0.2 0.3 0.4
on I t off

ground fault

tr = 1 s

tsd = 0.2 s

tg = 0.2 s

Thresholds

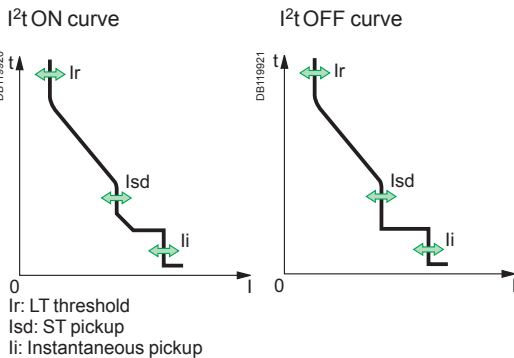

Time delays

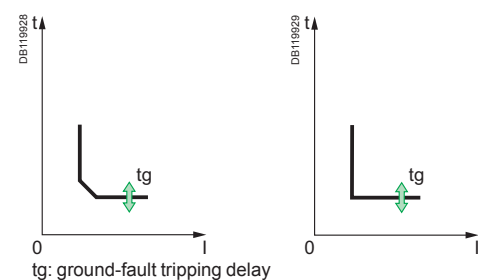
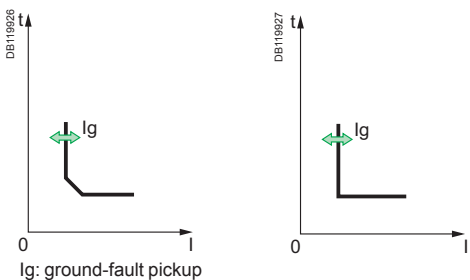
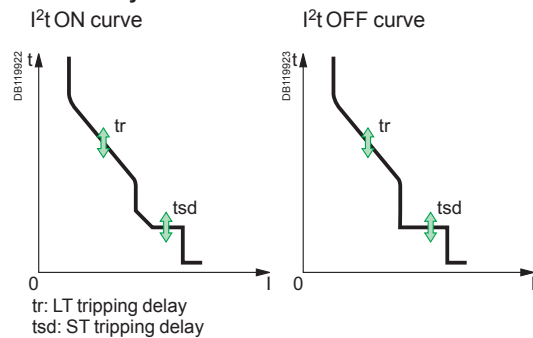

Setting Micrologic 7.0 P using the dials

Consider a 2000 A circuit breaker.

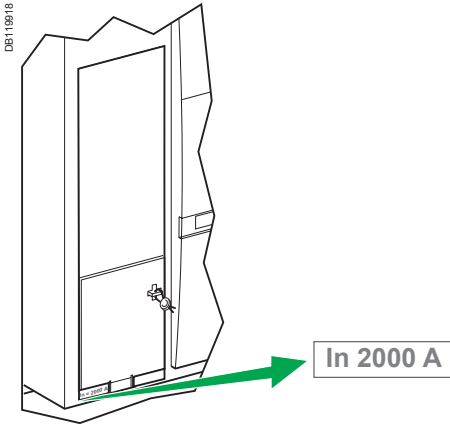

Set the thresholds

DB119830

long time
Ir
0.7 0.8 0.9 0.95 1
0.5 0.6 0.7 0.8 0.9 0.95 1
x In

short time
Isd
2.5 3 4 5 6 8 10
1.5 2 3 4 5 6 8 10
x Ir
setting

instantaneous
Ii
2 3 4 6 8 10 12 15 20
x In

IΔn (A)
1 2 3 5 7 10 20 30
0.5 1 2 3 5 7 10 20 30

earth leakage

In = 2000 A

Ir = 0.5 x 2000 = 1000 A

Isd = 2 x 1000 = 2000 A

Ii = 2 x 2000 = 4000 A

IΔn = 1 A

See pages 22 to 26 for selection of the setting ranges.

Set the time delays

DB119831

long time
tr (s)
1 2 4 8 12 16 20 24
0.5 @ 6 Ir

short time
tsd (s)
0.1 0.2 0.3 0.4
on I t off

delay
Δt (ms)
140 230 350 60 800

earth leakage

tr = 1 s

tsd = 0.2 s

Δt = 140 ms

Thresholds

I²t ON curve

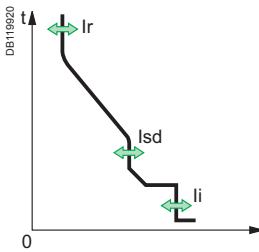

I²t OFF curve

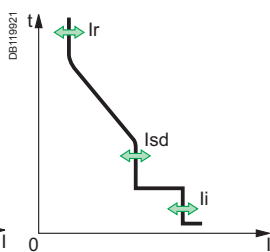

Time delays

I²t ON curve

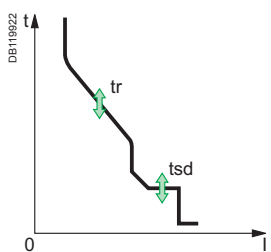

I²t OFF curve

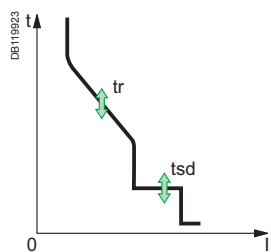

Ir: LT threshold
Isd: ST pickup
Ii: Instantaneous pickup

tr: LT tripping delay
tsd: ST tripping delay

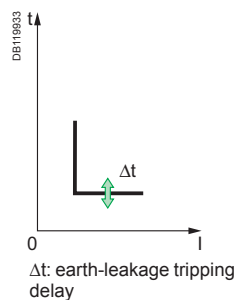
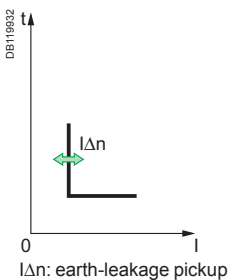

Selecting the type of neutral protection

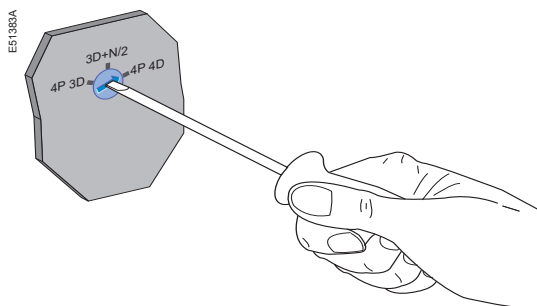

Selection dial on four-pole circuit breakers

On four-pole circuit breakers, it is possible to select the type of neutral protection for the fourth pole using the three-position dial on the circuit breaker:

- no neutral protection 4P 3D
- half neutral protection 3D + N/2
- full neutral protection 4P 4D

The factory default setting is 3D + N/2.

Important

With the 4P 3D setting, the current in the neutral must not exceed the rated current of the circuit breaker.

- The Micrologic P control unit offers access to the main screen and three menus:
- the main screen displaying the continuous measurement of the phase currents (I1, I2, I3) and the neutral current (IN), if it exists
 - the "Metering" menu
 - the "History, maintenance and setup" menu
 - the "Protection" menu.

Main screen

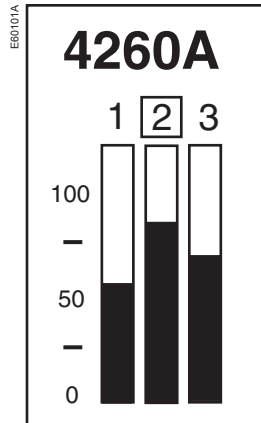

As long as no functions are activated, Micrologic P control units display in real time the current on the most heavily loaded phase. The number for that phase is presented in a square.

The current in the neutral is displayed if the neutral CT is set as internal or external (see "Inneutral (A)" settings in the "Current protection" menu).

When a menu button is pressed, a presentation screen is displayed and the green LED on the button goes ON.

"Metering", "History, maintenance and setup" and "Protection" menus

- "Metering" menu



The screenshot shows a menu with the following items:

I	(A)
U	(V)
P	(kW)
E	(kWh)
F	(Hz)

- press the or button to return to the main screen
- press the button to return to the previous screen
- whatever the screen displayed, if no further action is taken, the system returns to the main screen after a few minutes
- the LED goes OFF on exiting the menu.

■ "History, maintenance and setup" menu

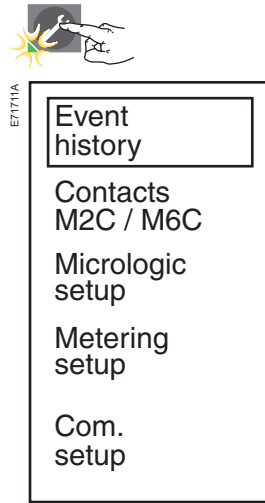

- press the or button to return to the main screen
- press the button to return to the previous screen
- whatever the screen displayed, if no further action is taken, the system returns to the main screen after a few minutes
- the LED goes OFF on exiting the menu.

■ "Protection" menu

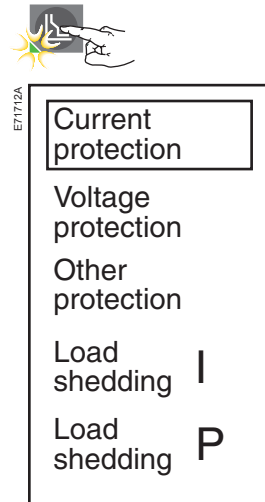





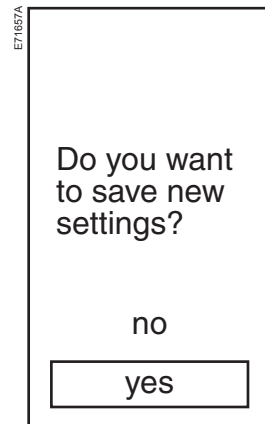

- press the or button to return to the main screen
- press the button to return to the previous screen
- whatever the screen displayed, if no further action is taken, the system returns to the main screen after a few minutes
- the LED goes OFF on exiting the menu.

■ Saving settings



- When a setting is made in any of the three menus, the screen used to save the modification(s) may be accessed by pressing one of the three buttons , or .
- select yes to save the modifications
 - select no to cancel and maintain the previous settings
 - this screen remains displayed until yes or no are selected.

Press the  button to select the "Metering" menu.

-  move the cursor down the screen or decrement a value.
-  move the cursor up the screen or increment a value.
-  select an option in a list, confirm a selection or the value of a setting.
-  indicates that the operator is in the "Metering" menu and returns to the previous screen.
-   return to the main screen.

Current measurements

I (A)  access to the following sections:

Instant. 

I1, I2, I3, IN I1, I2, I3, IN currents (depending on the type of system)

Max Storing and reset of the maximum instantaneous currents.

Demand 

I1, I2, I3, IN Demand current on the phases I1, I2, I3 and on IN (depending on the type of system)

Max Storing and reset of the maximum demand currents.

Voltage measurements

U (V)  access to the following sections:

Instant. Instantaneous phase-to-phase U12, U23, U31 and phase-to-neutral V1N, V2N, V3N voltages (depending on the type of system)

Average 3 Φ Average voltage U average of the phase-to-phase voltages.

Unbal 3 Φ Unbalance voltage U unbal. of the phase-to-phase voltages.

Phase rotation Phase sequence.

E60105A

I	(A)
U	(V)
P	(kW)
E	(kWh)
F	(Hz)

E600391A

I	(A)
U	(V)
P	(kW)
E	(kWh)
F	(Hz)

E60392A

I	(A)
U	(V)
P	(kW)
E	(kWh)
F	(Hz)

Power measurements

P (kW) 

access to the following sections:

Instant. 

P, Q, S,

Total active power P
Total reactive power Q
Total apparent power S

Power factor

Power factor PF

Demand 

$\bar{P}, \bar{Q}, \bar{S}$

Demand values for the:
■ total active power P
■ total reactive power Q
■ total apparent power S

Max

Storing and reset of the maximum demand power values

E60393A

I	(A)
U	(V)
P	(kW)
E	(kWh)
F	(Hz)

Energy measurements

E (kWh) 

access to the following sections:

E total

Total active energy E.P
Total reactive energy E.Q
Total apparent energy E.S

E in

Positive component of:
■ the total active energy E.P
■ the total reactive energy E.Q

E out

Negative component of:
■ the total active energy E.P
■ the total reactive energy E.Q

Reset Energy

Reset all the energy values to zero

E60394A





I	(A)
U	(V)
P	(kW)
E	(kWh)
F	(Hz)

Frequency measurement

F (Hz) 

access to the frequency measurement

Press the  button to select the "History, maintenance and setup" menu.

-  move the cursor down the screen or decrement a value.
-  move the cursor up the screen or increment a value.
-  select an option in a list, confirm a selection or the value of a setting.
-  indicates that the operator is in the "History, maintenance and setup" menu and returns to the previous screen.
-  return to the main screen.

E7171A

Event history

Contacts M2C / M6C

Micrologic setup

Metering setup

Com. setup

Event history

Event history  access to the following sections:

- Trip history The last ten faults recorded
- Alarm history The last ten alarms recorded
- Operation counter Number of operations (opening or closing)
- Contact wear Wear of the circuit-breaker main contacts

E71719A

Event history

Contacts M2C / M6C

Micrologic setup

Metering setup

Com. setup

M2C / M6C Contacts

Contacts M2C / M6C  access to the following sections:

- Alarm type Assignment of a protection alarm to an M2C or an M6C contact
- Setup Latching mode for each M2C or M6C contact
- Reset Reset of the M2C or M6C contacts

E71714A

Event history
Contacts M2C / M6C
Micrologic setup
Metering setup
Com. setup

Micrologic setup

Micrologic setup 

access to the following sections:

- Language** Selection of the display language
- Date / time** Setting of the date and time
- Breaker selection** Indication of the circuit-breaker type
- Power sign** Setting the power sign
- VT ratio** Select of the primary and secondary voltages on the instrument transformer
- System frequency** Indication of the rated system frequency

E71715A

Event history
Contacts M2C / M6C
Micrologic setup
Metering setup
Com. setup

Metering setup

Metering setup 

access to the following sections:

- System type**
 - 3 phases, 3 wires, 3 CTs: method using two wattmeters
 - 3 phases, 4 wires, 3 CTs: method using three wattmeters
 - 3 phases, 4 wires, 4 CTs: method using three wattmeters with measurement of the neutral current.
- Current demand** Selection of the calculation method and setting of the time interval for the calculation
- Power demand** Selection of the calculation method and setting of the parameters for the calculation
- Sign convention** Setting of the sign convention for the power factor and reactive power, i.e. IEEE, IEEE alternate or IEC (see page 87 to determine the sign convention)

E71716A

Event history
Contacts M2C / M6C
Micrologic setup
Metering setup
Com. setup







COM communications-option setup

Com. setup 

access to the following sections:

- Com. parameter** Setting of parameters for the COM communications option.
- Remote settings** Authorisation of access to settings via the COM communications option.
- Remote control** Authorisation of access to the circuit-breaker ON and OFF commands via the COM communications option.
- IP Data** Displays the IP address of the IFE.

Press the  button to select the "Protection" menu.

-  move the cursor down the screen or decrement a value
-  move the cursor up the screen or increment a value
-  select an option in a list, confirm a selection or the value of a setting
-  indicates that the operator is in the "Protection" menu and returns to the previous screen
-   return to the main screen

E71712A

Current protection

Voltage protection

Other protection

Load shedding I

Load shedding P

Current protection

Current protection  access to the following sections:

- I** (A) Fine settings of the long-time I^2t , short-time and instantaneous protection functions
- I_{dmtl}** (A) Fine settings of the long-time I_{dmtl} , short-time and instantaneous protection functions
- I_≠** (A) Fine settings of the:
 - ground-fault (Micrologic 6.0 P)
 - earth-leakage (Micrologic 7.0 P) protection functions
- I_{neutral}** (A) Selection of the type of neutral sensor and type of neutral protection
- I_≠Alarm** Setting of the **I_≠** alarm
- I_{unbal}** (%) Setting of the current-unbalance protection **I_{unbal}**
- I₁ max** (A) Setting of the maximum-current protection $\bar{I}_1 \text{ max}$
- I₂ max** (A) Setting of the maximum-current protection $\bar{I}_2 \text{ max}$
- I₃ max** (A) Setting of the maximum-current protection $\bar{I}_3 \text{ max}$
- I_N max** (A) Setting of the maximum-current protection $\bar{I}_N \text{ max}$

E71719A

- Current protection
- Voltage protection**
- Other protection
- Load shedding I
- Load shedding P

Voltage protection

Voltage protection

 access to the following sections:

U_{min} (V)

Setting of the minimum-voltage protection U_{min}.

U_{max} (V)

Setting of the maximum-voltage protection U_{max}.

U_{unbal} (%)

Setting of the voltage-unbalance protection U_{unbal}.

E71720A

- Current protection
- Voltage protection
- Other protection**
- Load shedding I
- Load shedding P

Other protection

Other protection

 access to the following sections:

rP_{max} (W)

Setting of the reverse-power protection rP_{max}

F_{min} (Hz)

Setting of the minimum-frequency protection F_{min}

F_{max} (Hz)

Setting of the maximum-frequency protection F_{max}

Phase rotation

Setting of the phase-rotation protection

E71721A

- Current protection
- Voltage protection
- Other protection
- Load shedding I**
- Load shedding P

Load shedding depending on current

Load shedding I

 Access to load shedding and reconnection depending on current

E71722A

- Current protection
- Voltage protection
- Other protection
- Load shedding I
- Load shedding P**

Load shedding depending on power

Load shedding P

 Access to load shedding and reconnection depending on power

For the default values, the setting ranges, increment steps and setting accuracies, see the technical appendix.

The long-time protection function protects cables against overloads. This function is based on true rms measurements. It is possible to select either I²t long-time protection or Idmtl long-time protection.

I²t long-time protection

Long-time current setting I_r and standard tripping delay t_r

Micrologic control unit	Accuracy	5.0 P, 6.0 P and 7.0 P									
Current setting tripping between 1.05 and 1.20 I _r	I _r = I _n (*) x ...	0.4	0.5	0.6	0.7	0.8	0.9	0.95	0.98	1	
		other ranges or disable by changing rating plug									
Time setting		0.5	1	2	4	8	12	16	20	24	
Time delay (s)	tr at 1.5 x I _r	0 to -30%	12.5	25	50	100	200	300	400	500	600
	tr at 6 x I _r	0 to -20%	0.7 ⁽¹⁾	1	2	4	8	12	16	20	24
	tr at 7.2 x I _r	0 to -20%	0.7 ⁽²⁾	0.69	1.38	2.7	5.5	8.3	11	13.8	16.6

* I_n: circuit breaker rating

⁽¹⁾ 0 to -40%

⁽²⁾ 0 to -60%

- It is possible to enhance the I_r setting accuracy (reduced range) or disable the long-time protection function by using a different long-time rating plug. See the technical appendix "Changing the long-time rating plug".

Thermal memory

- The thermal memory continuously accounts for the amount of heat in the cables, both before and after tripping, whatever the value of the current (presence of an overload or not). The thermal memory optimises the long-time protection function of the circuit breaker by taking into account the temperature rise in the cables.
- The thermal memory assumes a cable cooling time of approximately 15 minutes.

Idmtl Protection

Long-time current setting I_r and Idmtl tripping delay t_r

Micrologic control unit			Accuracy		5.0 P, 6.0 P and 7.0 P						
Current setting	$I_r = I_n (*) \times \dots$		0.4	0.5	0.6	0.7	0.8	0.9	0.95	0.98	1
tripping between 1.05 and 1.20 I_r			other ranges or disable by changing rating plug								
Time setting			0.5	1	2	4	8	12	16	20	24
DT											
Time delay (s)	tr at 1.5 x I_r	0 to -20%	0.53	1	2	4	8	12	16	20	24
	tr at 6 x I_r	0 to -20%	0.53	1	2	4	8	12	16	20	24
	tr at 7.2 x I_r	0 to -20%	0.53	1	2	4	8	12	16	20	24
	tr at 10 x I_r	0 to -20%	0.53	1	2	4	8	12	16	20	24
SIT											
Time delay (s)	tr at 1.5 x I_r	0 to -30%	1.9	3.8	7.6	15.2	30.4	45.5	60.7	75.8	91
	tr at 6 x I_r	0 to -20%	0.5	1	2	4	8	12	16	20	24
	tr at 7.2 x I_r	0 to -20%	0.7 ⁽¹⁾	0.88	1.77	3.54	7.08	10.6	14.16	17.7	21.2
	tr at 10 x I_r	0 to -20%	0.7 ⁽²⁾	0.8	1.43	2.86	5.73	8.59	11.46	14.33	17.19
VIT											
Time delay (s)	tr at 1.5 x I_r	0 to -30%	3.6	7.2	14.4	28.8	57.7	86.5	115.4	144.2	173.1
	tr at 6 x I_r	0 to -20%	0.5	1	2	4	8	12	16	20	24
	tr at 7.2 x I_r	0 to -20%	0.7 ⁽¹⁾	0.81	1.63	3.26	6.52	9.8	13.1	16.34	19.61
	tr at 10 x I_r	0 to -20%	0.7 ⁽²⁾	0.75	1.14	2.28	4.57	6.86	9.13	11.42	13.70
EIT											
Time delay (s)	tr at 1.5 x I_r	0 to -30%	12.5	25	50	100	200	300	400	500	600
	tr at 6 x I_r	0 to -20%	0.7 ⁽¹⁾	1	2	4	8	12	16	20	24
	tr at 7.2 x I_r	0 to -20%	0.7 ⁽²⁾	0.69	1.38	2.7	5.5	8.3	11	13.8	16.6
	tr at 10 x I_r	0 to -20%	0.7 ⁽²⁾	0.7 ⁽¹⁾	0.7 ⁽¹⁾	1.41	2.82	4.24	5.45	7.06	8.48
HVF											
Time delay (s)	tr at 1.5 x I_r	0 to -30%	164.5	329	658	1316	2632	3950	5265	6581	7900
	tr at 6 x I_r	0 to -20%	0.7 ⁽¹⁾	1	2	4	8	12	16	20	24
	tr at 7.2 x I_r	0 to -20%	0.7 ⁽²⁾	0.7 ⁽¹⁾	1.1 ⁽¹⁾	1.42	3.85	5.78	7.71	9.64	11.57
	tr at 10 x I_r	0 to -20%	0.7 ⁽²⁾	0.7 ⁽²⁾	0.7 ⁽¹⁾	0.7 ⁽¹⁾	1.02	1.53	2.04	2.56	3.07

* I_n : circuit breaker rating

(1) 0 to -40%

(2) 0 to -60%

- These curves with different slopes are used to improve:
 - discrimination with fuses positioned upstream (HV) and/or downstream
 - protection for certain types of loads

■ Five types of curves are available:

- DT: definite time curve
- SIT: standard inverse time curve ($I^{0.5}t$)
- VIT: very inverse time curve (It)
- EIT: extremely inverse time curve (I^2t)
- HVF: compatible with high-voltage fuses (I^4t).

■ **Neutral protection**

Overload protection (long time) for the neutral is disabled if the Idmtl protection function is selected. However, the short-circuit protection (short time and instantaneous) remains operational.

■ **Intermittent overloads**

As long as the Micrologic P control unit remains supplied with power, the effects of intermittent overloads on cables are calculated. If power is cut, temperature rise in cables is not calculated.

■ **Circuit-breaker thermal limit**

For certain settings, the Idmtl curves may be limited by the I^2t curve when the tripping delay t_r is set to 24 seconds or by its thermal memory. The maximum I^2t curve remains active for the phases and the neutral even when the Idmtl curves are activated.

For the default values, the setting ranges, increment steps and setting accuracies, see the technical appendix.

For the characteristics and external wiring of the zone selective interlocking function, see the technical appendix on "Zone selective interlocking".

Short-time protection

- The short-time protection function protects the distribution system against impedant short-circuits
- The short-time tripping delay and the I²t ON and I²t OFF options can be used to ensure discrimination with a downstream circuit breaker
- This function carries out true rms measurements.

- Use of I²t curves with short-time protection:
 - I²t OFF selected: the protection function implements a constant time curve
 - I²t ON selected: the protection function implements an I²t inverse-time curve up to 10 I_r. Above 10 I_r, the time curve is constant.

- Zone selective interlocking (ZSI)
 The short-time and ground-fault protection functions enable time discrimination by delaying the upstream devices to provide the downstream devices the time required to clear the fault. Zone selective interlocking can be used to obtain total discrimination between circuit breakers using external wiring.

- Intermittent faults are taken into account by Micrologic P and may lead to shorter tripping times than those set.

Short-time pickup I_{sd} and tripping delay t_{sd}

Micrologic control unit		5.0 P, 6.0 P and 7.0 P								
Pickup	I _{sd} = I _r x ... accuracy ± 10 %	1.5	2	2.5	3	4	5	6	8	10
Time delay (s)	setting	I ² t Off	0	0.1	0.2	0.3	0.4			
		I ² t On		0.1	0.2	0.3	0.4			
I ² t On or	t _{sd} (max resettable time) (ms)	20	80	140	230	350				
I ² t Off	t _{sd} (max break time) (ms)	80	140	200	320	500				

If the "without long-time protection" plug is used and the long-time protection function is disabled, the short-time pickup I_{sd} is automatically multiplied by I_n instead of I_r as is the standard case.

Instantaneous protection

- The instantaneous-protection function protects the distribution system against solid short-circuits. Contrary to the short-time protection function, the tripping delay for instantaneous protection is not adjustable. The tripping order is sent to the circuit breaker as soon as current exceeds the set value, with a fixed time delay of 20 milliseconds.
 - This function carries out true rms measurements.
 - The energy reduction maintenance setting (ERMS) function is added to the instantaneous protection function by addition of an optional IO module to the IMU configured to perform the pre-defined application 3 or the ERMS user-defined application.
- For more information, refer to IO Input/Output Interface for LV circuit breaker user guide.

Instantaneous pickup I_i

Micrologic control unit		5.0 P, 6.0 P and 7.0 P								
Pickup	I _i = I _n (*) x ... accuracy ± 10 %	2	3	4	6	8	10	12	15	OFF

* I_n: circuit-breaker rating

- Circuit breakers have two types of instantaneous protection:
 - adjustable instantaneous protection I_i
 - self-protection.
- Depending on the circuit breaker, the OFF position corresponds to the self-protection pickup.

Energy reduction maintenance settings (ERMS) function

The energy reduction maintenance setting (ERMS) function is available on circuit breaker fitted with:

- a BCM ULP with firmware version 4.1.0 and above.
- a Micrologic P control unit:
 - with firmware version Plogic-2014AN and above.
 - with hardware compatible with the ERMS function. Use the customer engineering tool to check the Micrologic hardware version, or the COM option to check that the hardware version coded in register 8709 is equal to 0x1000.

The ERMS function allows the selection of the Micrologic control unit settings: Normal and ERMS mode.

The ERMS function is used to reduce the Ii protection settings in order to trip as fast as possible when a fault occurs. The factory setting for Ii protection in ERMS mode is 2xIn. This protection parameter can be modified using the customer engineering tool. If any of the basic protection settings using the rotary dial is modified on the Micrologic control unit while in ERMS mode, the Micrologic control unit switches immediately to the normal mode. The Micrologic control unit returns automatically to the ERMS mode after 5 seconds.

The selection of the normal or ERMS mode is made by a selector switch connected to two inputs of the IO module.

When the ERMS mode is engaged, ERMS is shown on the display of the Micrologic control unit and a pilot light connected to the output O3 of the IO module will be in ON state.

ERMS may be activated after a short delay due to internal controls in the system. Ensure that the Output 3 (O3) of IO Module is ON and Micrologic HMI displays ERMS before operating the equipment.

⚠ DANGER

HAZARD OF ARC FLASH

- Do not change the Micrologic P or H control unit's setting while in ERMS mode.
- Seal the transparent cover of the Micrologic P and H control unit when using the ERMS mode.

Failure to follow these instructions will result in death or serious injury.

Micrologic display with ERMS mode engaged.

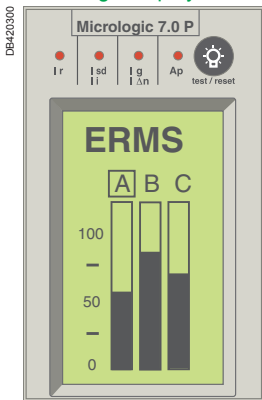

The locking pad of the communication interface module (IFM or IFE) must be in UNLOCK position (padlock open) while performing the energy reduction maintenance setting (ERMS).

The parameter ACCESS PERMIT in the COM setup/Remote setting menu on the display of the Micrologic control unit must be set to YES for IMU without IFM/IFE. This is based on the following behavior:

- IMU with IFM/IFE
 - Setting access permit parameter: The access permit parameter can be changed only from IFE/IFM using the LOCK/UNLOCK dial.
 - Behavior: ERMS ON and OFF orders are executed even if access permit parameter is set as NO.
- IMU without IFM/IFE
 - Setting access permit parameter: The access permit parameter can be changed only from the display of the Micrologic control unit.
 - Behavior: ERMS ON and OFF orders are not executed if access permit parameter is set as NO.

Note:

The ERMS ON and OFF orders are executed only when the access parameter is set to YES and the passcode in the Micrologic control unit must be set to 0000.

If the ERMS function or COM option is used, it is advised to use a second dedicated power supply to supply the Micrologic P control unit (terminals F1-, F2+).



The AD power supply is recommended due to its low stray primary secondary capacitance. Good operation of the Micrologic control unit in noisy environment is not guaranteed with other power supplies.

Current protection

Neutral protection

For the default values, the setting ranges, increment steps and setting accuracies, see the technical appendix.

Three-pole circuit breakers



Protection of the neutral is possible on a three-pole circuit breaker by connecting an external sensor. Settings are made using the  and  buttons on the control unit.

Micrologic control unit	5.0 P, 6.0 P and 7.0 P			
Setting	OFF	N/2	N	1.6xN

Type of neutral	Description
No neutral protection	The distribution system does not require protection of the neutral conductor.
Half neutral protection	The cross-sectional area of the neutral conductor is half that of the phase conductors. <ul style="list-style-type: none"> ■ The long-time current setting I_r for the neutral is equal to half the setting value ■ The short-time pickup I_{sd} for the neutral is equal to half the setting value ■ The instantaneous pickup I_i for the neutral is equal to the setting value ■ For ground-fault protection (Micrologic 6.0 P), pickup I_g for the neutral is equal to the setting value.
Full neutral protection	The cross-sectional area of the neutral conductor is equal to that of the phase conductors. <ul style="list-style-type: none"> ■ The long-time current setting I_r for the neutral is equal to the setting value ■ The short-time pickup I_{sd} for the neutral is equal to the setting value ■ The instantaneous pickup I_i for the neutral is equal to the setting value ■ For ground-fault protection (Micrologic 6.0 P), pickup I_g for the neutral is equal to the setting value.
Oversized neutral protection	In installations with a high level of third-order harmonic currents (or multiples thereof), the current in the neutral conductor may exceed that of the phase currents under steady-state conditions <ul style="list-style-type: none"> ■ The long-time current setting I_r for the neutral is 1.6 times that of the setting value ■ The short-time pickup I_{sd} for the neutral is 1.6 times that of the setting value, but may not exceed $10 I_n$ to limit transients and self-protect the installation ■ The instantaneous pickup I_i for the neutral is equal to the setting value ■ For ground-fault protection (Micrologic 6.0 P), pickup I_g for the neutral is equal to the setting value.

Four-pole circuit breakers

The initial protection setting is made using the dial on the neutral pole of the circuit breaker.

The  and  buttons on the control unit may then be used for a more precise setting. The dial setting constitutes the upper limit for adjustments using the keypad.

Micrologic control unit	5.0 P, 6.0 P and 7.0 P		
Setting	OFF	N/2	N

Type of neutral	Description
No neutral protection	The distribution system does not require protection of the neutral conductor.
Half neutral protection	The cross-sectional area of the neutral conductor is half that of the phase conductors. <ul style="list-style-type: none"> ■ The long-time current setting I_r for the neutral is equal to half the setting value ■ The short-time pickup I_{sd} for the neutral is equal to half the setting value ■ The instantaneous pickup I_i for the neutral is equal to the setting value
Full neutral protection	The cross-sectional area of the neutral conductor is equal to that of the phase conductors. <ul style="list-style-type: none"> ■ The long-time current setting I_r for the neutral is equal to the setting value ■ The short-time pickup I_{sd} for the neutral is equal to the setting value ■ The instantaneous pickup I_i for the neutral is equal to the setting value.

Current protection

Ground-fault and earth-leakage protection

For the default values, the setting ranges, increment steps and setting accuracies, see the technical appendix.

Ground-fault protection on Micrologic 6.0 P

■ An ground fault in the protection conductors can provoke local temperature rise at the site of the fault or in the conductors. The purpose of the ground-fault protection function is to eliminate this type of fault.

■ There are two types of ground-fault protection.

Type	Description
Residual	<ul style="list-style-type: none"> ■ The function determines the zero-phase sequence current, i.e. the vector sum of the phase and neutral currents (depending on the type of installation)
Source Ground Return	<ul style="list-style-type: none"> ■ Using a special external sensor, this function directly measures the fault current returning to the transformer via the earth cable ■ It detects faults both upstream and downstream of the circuit breaker ■ The maximum distance between the sensor and the circuit breaker is ten metres.

■ Ground-fault and neutral protection are independent and can therefore be combined.

Ground-fault pickup I_g and tripping delay t_g

The pickup and tripping-delay values can be set independently and are identical for both the residual and "source ground return" ground-fault protection functions.

Micrologic control unit		6.0 P									
Pickup	$I_g = I_n (*) \times \dots$ accuracy $\pm 10\%$	A	B	C	D	E	F	G	H	J	
	$I_n \leq 400\text{ A}$	0.3	0.3	0.4	0.5	0.6	0.7	0.8	0.9	1	
	$400\text{ A} < I_n \leq 1200\text{ A}$	0.2	0.3	0.4	0.5	0.6	0.7	0.8	0.9	1	
	$I_n > 1200\text{ A}$	500 A	640 A	720 A	800 A	880 A	960 A	1040 A	1120 A	1200 A	
Time delay (s) at I_n or 1200 A	settings	I^2t Off	I^2t Off	0	0.1	0.2	0.3	0.4			
		I^2t On		0.1	0.2	0.3	0.4				
I^2t On or	t_g (max resettable time) (ms)	20	80	140	230	350					
I^2t Off	t_g (max. break time) (ms)	80	140	200	320	500					

(*) I_n : circuit-breaker rating

Earth-leakage protection on sur Micrologic 7.0 P

■ The earth-leakage protection function primarily protects people against indirect contact because an earth-leakage current can provoke an increase in the potential of the exposed conductive parts. The earth-leakage pickup value $I_{\Delta n}$ is displayed directly in amperes and the tripping delay follows a constant-time curve.

■ An external rectangular sensor is required for this function

■ This function is inoperative if the long-time rating plug is not installed

Δ Protected against nuisance tripping

\sim DC-component withstand class A up to 10 A.

■ If the optional external voltage-measurement input is used, a 24 V DC external power supply must be connected to Micrologic P (terminals F1-, F2+).

Pickup value $I_{\Delta n}$ and tripping delay Δt

Micrologic control unit		7.0 P									
Pickup (A)	$I_{\Delta n}$ accuracy 0 to -20 %	0.5	1	2	3	5	7	10	20	30	
Time delay (ms) settings	Δt (max resettable time)	60	140	230	350	800					
	Δt (max. break time)	140	200	320	500	1000					

Current protection

I_{\perp} Alarm, current unbalance, maximum current

For the pickup and dropout thresholds and time delays, see the technical appendix.

Operating principle

Protection tripped by a maximum value

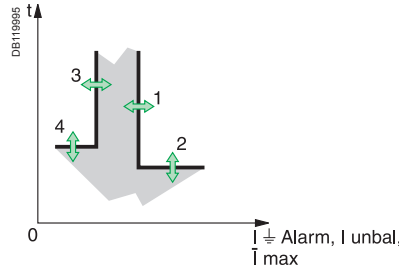

- 1: pickup threshold
- 2: pickup time delay
- 3: dropout threshold
- 4: dropout time delay

- For protection tripped by a maximum value, it is possible to set:
 - a pickup threshold (1) that activates an alarm, a contact and/or tripping
 - a pickup time delay (2) that steps in when the pickup threshold (1) is reached
 - a dropout threshold (3) corresponding to deactivation of the alarm and/or contact
 - a dropout time delay (4) that steps in when the dropout threshold (3) is reached
- The dropout threshold is always less than or equal to the pickup threshold.

I_{\perp} Alarm

- The alarm function is tripped by the rms value of an earth-leakage current
- This alarm signals an earth-leakage current under the pickup value and does not produce circuit-breaker tripping.

Current-unbalance protection I_{unbal}

- This protection is activated by an adjustable level of unbalance between the RMS values of the three phase currents.

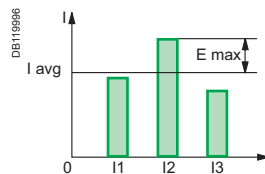

- From:
 - I_{avg} is the average value of the rms currents of the three phases

$$I_{avg} = \frac{I_1 + I_2 + I_3}{3}$$

- E_{max} is the maximum difference between the current of each phase and I_{avg}

- Micrologic P uses the two values above to calculate the current unbalance:

$$I_{unbal} = \frac{E_{max}}{I_{avg}}$$

Maximum-current protection per phase \bar{I}_{max}

- Protection values may be set for each of the following currents:
 - \bar{I}_1 max: maximum current on phase 1
 - \bar{I}_2 max: maximum current on phase 2
 - \bar{I}_3 max: maximum current on phase 3
 - \bar{I}_N max: maximum current in the neutral
- This function calculates the rms demand value of the current for the given phase ($\bar{I}_1, \bar{I}_2, \bar{I}_3$) or the neutral (\bar{I}_N), over a sliding time interval. The time interval is the same as that for the calculation of the demand currents in the "Metering" menu.
- Settings are made in the "Metering setup" menu.

Note:

\bar{I}_N max protection does not take into account the neutral-protection setting (N, N/2, 1.6xN, OFF).

Voltage protection

Minimum voltage, maximum voltage, voltage unbalance

For the pickup and dropout thresholds and time delays, see the technical appendix.

Operating principle

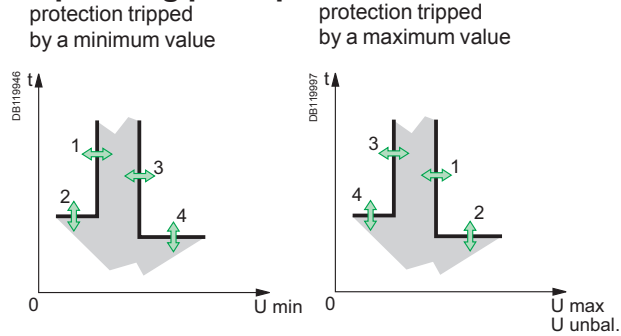

- 1: pickup threshold
- 2: pickup time delay
- 3: dropout threshold
- 4: dropout time delay

- For protection tripped by a minimum or maximum value, it is possible to set:
 - a pickup threshold (1) that activates an alarm, a contact and/or tripping
 - a pickup time delay (2) that steps in when the pickup threshold (1) is reached
 - a dropout threshold (3) corresponding to deactivation of the alarm and/or contact
 - a dropout time delay (4) that steps in when the dropout threshold (3) is reached
- For protection tripped by a minimum value, the dropout threshold is always greater than or equal to the pickup threshold
- For protection tripped by a maximum value, the dropout threshold is always less than or equal to the pickup threshold
- If both the minimum and maximum protection functions are activated at the same time, the minimum threshold is automatically limited to the value of the maximum and vice versa.

If the voltage protection functions are activated and the voltage measurement inputs are still energised, it is impossible to reset and close the circuit breaker.

Minimum-voltage protection U min

- This function calculates the minimum rms value of the three phase-to-phase voltages
- Protection is activated when at least one of the three phase-to-phase voltages (U12, U23, U31) is below the threshold set by the user
- This protection function does not detect phase failure.

Maximum-voltage protection U max

- This function calculates the maximum rms value of the three phase-to-phase voltages
- Protection is activated when the three phase-to-phase voltages (U12, U23, U31) are simultaneously above the threshold set by the user.

Voltage-unbalance protection U unbal

This protection is activated by an adjustable level of unbalance between the rms values of the three phase-to-phase voltages. This function calculates the rms value of the unbalance between the three phase-to-phase voltages.

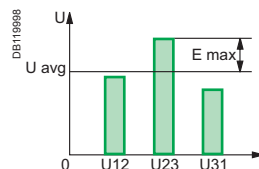

- From:
 - U avg is the average value of the rms voltages of the three phases
$$U_{avg} = \frac{U_{12} + U_{23} + U_{31}}{3}$$
- E max: is the maximum difference between the voltage of each phase and U avg
- Micrologic P uses the two values above to calculate the voltage unbalance:
$$U_{unbal} = \frac{|E_{max}|}{U_{avg}}$$

Other protection

Reverse power, min. frequency, max. frequency, phase rotation

For the pickup and dropout thresholds and time delays, see the technical appendix.

Operating principle

protection tripped by a minimum value

protection tripped by a maximum value

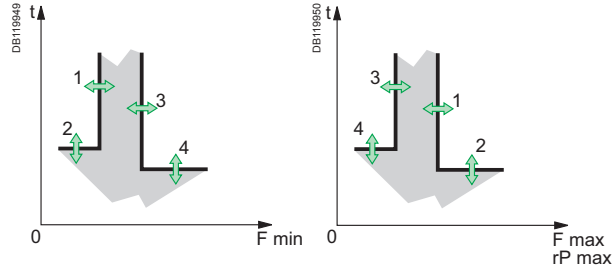

- 1: pickup threshold
- 2: pickup time delay
- 3: dropout threshold
- 4: dropout time delay

- For protection tripped by a minimum or maximum value, it is possible to set:
 - a pickup threshold (1) that activates an alarm, a contact and/or tripping
 - a pickup time delay (2) that steps in when the pickup threshold (1) is reached
 - a dropout threshold (3) corresponding to deactivation of the alarm and/or contact
 - a dropout time delay (4) that steps in when the dropout threshold (3) is reached
- For protection tripped by a minimum value, the dropout threshold is always greater than or equal to the pickup threshold
- For protection tripped by a maximum value, the dropout threshold is always less than or equal to the pickup threshold
- If both the minimum and maximum protection functions are activated at the same time, the minimum threshold is automatically limited to the value of the maximum and vice versa.

Reverse-power protection rP max

- This function calculates the value of the total active power on the three phases
- The function is activated when the total active power of the three phases flows in the direction opposite that set by the user is greater than the pickup threshold (1) for a time greater than the time delay (2).

Note:

The direction of flow is set by the user in the "Power sign" section of the "Micrologic setup" menu under "History, maintenance and settings".

- + corresponds to the normal direction of flow, i.e. from the top terminals on the circuit breaker to the bottom terminals
- - is the opposite.

If the voltage protection functions are activated and the voltage measurement inputs are still energised, it is impossible to reset and close the circuit breaker.

Minimum and maximum-frequency protection F min. and F max

These functions monitor the value of the frequency on the distribution system.

Phase-rotation alarm

This alarm is activated if two of the three phases are inverted.

Note:

The alarm is activated following a fixed 300-millisecond time delay. If one of the phases is absent, the alarm will not operate. If the 400 Hz frequency is set, the alarm cannot be activated.

Load shedding and reconnection

For the pickup and dropout thresholds and time delays, see the technical appendix.

Load shedding and reconnection depending on current

The pickup curve for load shedding and reconnection depending on current is parallel to the LT I^2t and IdmtI curves. If a "without long-time protection" rating plug is installed, the load shedding/reconnection function based on current cannot be activated.

- I^2t protection: the neutral is taken into account
- IdmtI: the neutral is not taken into account.

This function does not trip the circuit breaker, but can be used to set off an alarm linked to an M2C or M6C contact (disconnection and reconnection of non-priority loads).

The load-shedding and reconnection function is determined by thresholds and time delays.

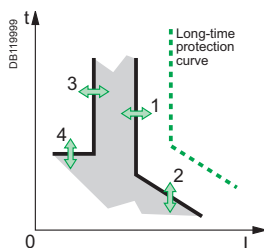

- 1: pickup threshold
- 2: pickup time delay
- 3: dropout threshold
- 4: dropout time delay

The pickup threshold is always greater than or equal to the dropout threshold.

Load shedding and reconnection depending on power

Load shedding and reconnection depending on power calculates the total active power on the three phases. This function does not trip the circuit breaker, but can be used to set off an alarm linked to an M2C or M6C contact (disconnection and reconnection of non-priority loads).

The load-shedding and reconnection function is determined by thresholds and time delays.

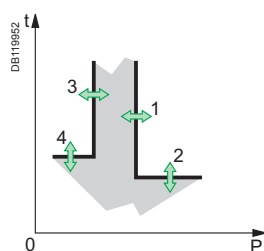

- 1: pickup threshold
- 2: pickup time delay
- 3: dropout threshold
- 4: dropout time delay

The pickup threshold is always greater than or equal to the dropout threshold.

For the setting ranges and measurement accuracies, see the technical appendix.

Instantaneous current

Micrologic P control units offer two, non-exclusive measurement possibilities.

- On the bargraph display on the main screen
The instantaneous current of the most heavily loaded phase is automatically displayed in amperes for phases 1, 2, 3 and the neutral (depending on the neutral protection settings). The bargraph indicates the percent load of the three phases.
- In the I inst. section of the instantaneous currents
 - display in amperes of the instantaneous currents I (rms) on phases I1, I2 and I3 and the neutral current IN, the ground-fault current Ig (Micrologic 6.0 P), the earth-leakage current IΔn (Micrologic 7.0 P)
 - the maximum instantaneous currents are displayed and stored in memory
 - the stored maximums can be reset at any time.

Demand current

- Display of the demand current on phases I1, I2, I3 and the neutral IN (depending on the type of distribution system)
- Selection of the demand calculation method
- Display of the interval over which the value is calculated
- The maximum demand values are displayed and stored in memory
- The stored maximums can be reset at any time.

Note:

The calculation method, the type of calculation window (fixed or sliding) and its duration may be set in the "Metering setup" menu under "History, maintenance and setup".

Phase-to-neutral and phase-to-phase voltages

Micrologic P offers different voltage measurements:

- Phase-to-phase voltages (rms) between phases U12, U23 and U31, displayed in volts
- Phase-to-neutral voltages (rms) between the phases and the neutral V1N, V2N and V3N, displayed in volts.

Average voltage

Average Uavg of the instantaneous voltages between phases U12, U23 and U31.

Phase rotation

Displays the phase sequence.

To display the phase-to-neutral voltages, select the "3Φ 4Φ 4CT" option in "System type" in the "Metering setup" menu under "History, maintenance and setup".

Voltage unbalance

Display of the unbalance Uunbal between the three phase-to-phase voltages, displayed as a percentage.

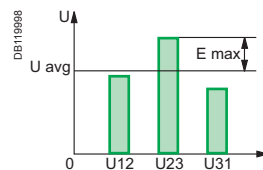

- From:
 - U avg is the average value of the rms voltages of the three phases

$$U_{avg} = \frac{U_{12} + U_{23} + U_{31}}{3}$$

- E max is the maximum difference between the voltage of each phase and U avg
- Micrologic P uses the two values above to calculate the voltage unbalance

$$U_{unbal} = \frac{|E_{max}|}{U_{avg}}$$

For the setting ranges and measurement accuracies, see the technical appendix.

Instantaneous power and power factor

Micrologic P offers a number of different measurements.

- Total power measurements:
 - instantaneous active power P in kW
 - instantaneous reactive power Q in kvar
 - instantaneous apparent power S in kVA
- Measurement of the power factor PF.

Demand power

- Display of the demand values for the active power P, reactive power Q and apparent power S
- Selection of the demand calculation method
- Display of the interval over which the value is calculated
- The maximum demand values are displayed and stored in memory
- The stored maximums can be reset at any time.

Note:

- the calculation method, the type of calculation window (fixed or sliding) and its duration may be set in the "Metering setup" menu under "History, maintenance and setup".
- the synchronisation function (Synchro.Com) is available only with the COM communication option; with this function, the demand power is determined on the basis of a signal synchronised by the communication module.
- these settings apply to all demand powers (active power P, reactive power Q and apparent power S). If the settings are modified, the demand values are systematically recalculated.

Energy

Micrologic P offers a number of different measurements:

- Total energy:
 - total active energy E.P in kWh
 - total reactive energy E.Q in kvarh
 - total apparent energy E.S in kVAh
- Energy consumed (Energy in), positively incremented:
 - active energy E.P in kWh
 - reactive energy E.Q in kvarh
- Energy supplied (Energy out), negatively incremented:
 - active energy E.P in kWh
 - reactive energy E.Q in kvarh
- Energy values can be reset.

Note:

- the Energy in and Energy out values are incremented according to the power sign set in the "Metering setup" menu under "History, maintenance and setup".
 - as standard, the total calculated energy values are "absolute total values". They represent the sum of the energy in and out values:
 - $EP = \sum EP_{in} + \sum EP_{out}$
 - $EQ = \sum EQ_{in} + \sum EQ_{out}$
 - as an option (access exclusively via the COM communications option), energy can be calculated algebraically:
 - $EP = \sum EP_{in} - \sum EP_{out}$
 - $EQ = \sum EQ_{in} - \sum EQ_{out}$
- These values are called "signed" energies.

Frequency

The frequency of the distribution system is displayed in Hz.

For information on the communications option and the portable test kit, see the respective user guides.

- An alarm may be viewed using:
 - the "Alarm history" menu
 - the COM communications option
 - the portable test kit.
- The commands in the "Protection" menu are used to attribute a specific operating mode to each of the protection functions:
 - OFF: protection disabled
 - Alarm: the function issues an alarm, but does not trip the circuit breaker
 - Trip + Alarm: the function issues an alarm and trips the circuit breaker.
- The protection functions against overloads (long time), short circuits (short time and instantaneous) and ground faults (ground-fault and earth-leakage currents) automatically result in tripping and cannot be deactivated (Trip mode only).
- The "I_Δ Alarm" and phase rotation alarms can be set exclusively to OFF or Alarm mode.
- The other protection functions for current, voltage, power and frequency may be set to any of the three modes, OFF, Alarm or Trip + Alarm.
- The load shedding and reconnection function may be set to ON or OFF.
- The resettable alarms linked to device tripping are activated when the I_r, I_{sd}/I_l or I_Δ thresholds are overrun. The I_r alarm is reset one second after tripping. The I_{sd}/I_l and I_Δ alarms are reset by pressing the  button.

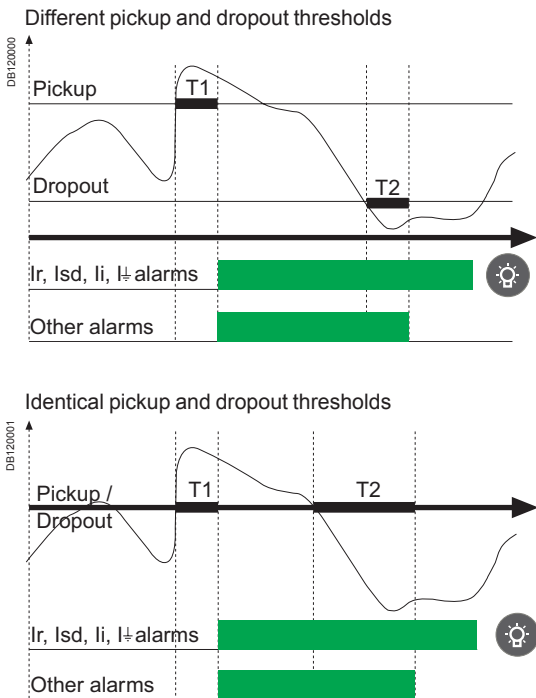

Current protection	Off	Alarm	Trip + Alarm
I _r			■
I _{sd} / I _l			■
I _Δ			■

- Delayed alarms are activated when the pickup and dropout thresholds are overrun and the corresponding time delays have expired.

Current protection	Off	Alarm	Trip + Alarm
I _Δ Alarm	■	■	
I unbal	■	■	■
T ₁ max	■	■	■
T ₂ max	■	■	■
T ₃ max	■	■	■
T _N max	■	■	■

Voltage protection	Off	Alarm	Trip + Alarm
U min	■	■	■
U max	■	■	■
U unbal	■	■	■

Other protection	Off	Alarm	Trip + Alarm
rP max	■	■	■
F min	■	■	■
F max	■	■	■
Phase rotation	■	■	

Shedding/reconnection	Off	On
current I	■	■
power P	■	■

- History logging
 - Alarm mode: as soon as a given protection threshold is overrun, an alarm is recorded in the "Alarm history"
 - Trip mode: as soon as a given protection threshold is overrun, the circuit breaker trips and the fault is recorded in the "Trip history".
- The "Protection setup" menu under "History, maintenance and setup" is used to enable or disable the Trip mode that is displayed in the protection-setting screens. On leaving the factory, the protection functions are set to Alarm mode.
- The "M2C / M6C contacts" menu under "History, maintenance and setup" is used to link an M2C or M6C contact to an alarm. M2C and M6C contacts may not be used together. They require a 24 V external power supply.
- The COM communications module can be used to transmit alarms to a supervisor.

The interrupted currents are indicated in terms of their peak values.

Trip history

- The trip history is the means to display at any time the parameters measured during the last ten trips.
- For each trip, the following parameters are recorded:
 - tripping cause
 - trip threshold
 - interrupted currents in amperes (only if an external power supply is present) for Ir, Isd/li, Ig or IΔn trips
 - date
 - time (hours, minutes and seconds).

Alarm history

- The alarm history is the means to display at any time the parameters measured during the last ten alarms.
- For each alarm, the following parameters are recorded:
 - alarm cause
 - alarm threshold
 - date
 - time (hours, minutes and seconds).

Operation counter

This function is available only via the COM communications option.

- Micrologic P:
 - stores and displays the total number of operations (incremented each time the circuit breaker opens) since the initial installation of the circuit breaker
 - stores and displays the total number of operations since the last reset.

Contact wear indication

This function can be used to:

- Determine the condition of the most worn contact in the circuit breaker. A counter is displayed on the screen. The contacts must be inspected each time the counter reaches a hundred mark. The message "Not available or circuit breaker type not defined" is displayed if the type of circuit breaker has not been defined. In this case, see "Breaker selection" in the "Micrologic setup" menu under "History, maintenance and setup".
- Reset the indicator after changing the main contacts. Reset is also carried out via "Breaker selection" in the "Micrologic setup" menu.

Note:

If the control unit is changed, the circuit breaker must be defined again. In this case, see "Breaker selection" in the "Micrologic setup" menu under "History, maintenance and setup".

LED indicator

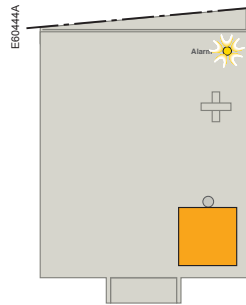

Signals overrun of the long-time current setting ($1.125 \times I_r$).

Overload bargraph on the main screen

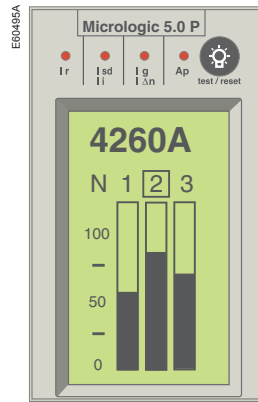

Signals the load level on each phase as a percentage of I_r .

The procedure required to reclose the circuit-breaker following a fault trip is presented in the circuit-breaker user guide.

Concerning the presence or absence of an external power supply, see the "Power supply" section in the technical appendix.

Important

The battery maintains the trip indications. If no indications are displayed, check the battery.

Fault-trip indications

■ Control-unit status

The circuit breaker has tripped.

The control unit may or may not have an external power supply.

The voltage measurement inputs may be connected upstream or downstream.

□ control unit without an external power supply and with voltage measurement input connected downstream

□ control unit with an external power supply and with voltage measurement input connected upstream

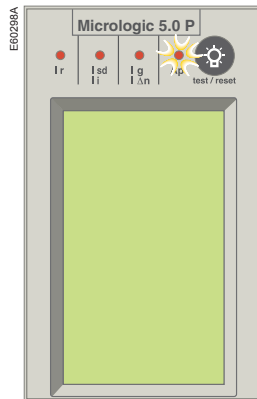

A LED signals the type of fault (I_r , I_{sd} , I_i , I_g , $I_{\Delta n}$ or A_p).

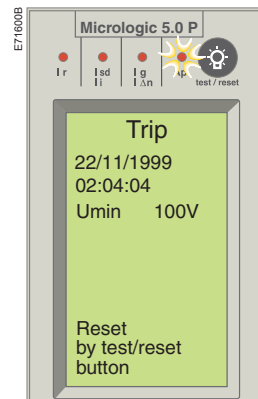

The type of fault is signalled by a LED and on the graphic display.

- Fault-trip LEDs
- The LEDs indicate the type of fault that tripped the circuit breaker
- The LEDs are located in the upper part of the front panel (red Ir, Isd, li, Ig, I²n and Ap LEDs)
- When activated, a LED remains ON until it is locally reset.

■ Ir LED

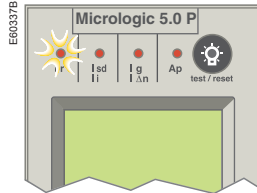

Signals tripping following overrun of the long-time current setting Ir.

■ Isd, li LED

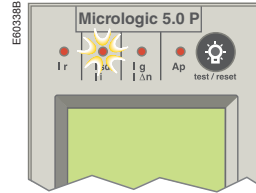

Signals tripping following overrun of the short-time pickup Isd or the instantaneous pickup li.

■ Ig, I²n LED

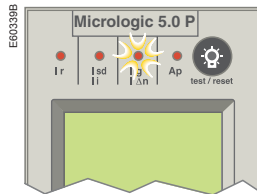

Signals tripping following overrun of the ground-fault pickup Ig or the earth-leakage pickup I²n.

■ Ap LED

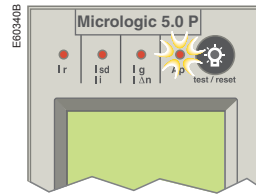

- Signals tripping due to:
- Self-protection function:
 - temperature
 - ASIC power supply
 - instantaneous pickup for circuit-breaker self protection
 - Protection functions:
 - current unbalance I unbal
 - maximum current I₁ max, I₂ max, I₃ max, I_N max;
 - voltage unbalance U unbal
 - maximum voltage U max
 - minimum voltage U min
 - reverse power rP max
 - maximum frequency F max
 - minimum frequency F min.

The self-protection function (excessive temperature, fault detected in ASIC power supply or instantaneous self-protection built into the device) trips the circuit breaker and turns the Ap LED on.

A number of simultaneous causes may result in tripping. For example, a short-circuit and a distribution-system voltage under a set value. The LED signalling the last fault chronologically is the only one to remain ON. E.g., the Ap LED may signal a voltage drop under a set value where the voltage drop was caused by a short-circuit.

■ LEDs on buttons to access the menus

The activated LED indicates the menu for which the screen is displayed:

- "Metering"
- "History, maintenance and setup"
- "Protection".



All the Masterpact devices can be fitted with the communication function. Masterpact uses the Ethernet or Modbus communication protocols for full compatibility with the supervision management systems.

Eco COM is limited to the transmission of metering data and status. It is not used to communicate controls.

BCM ULP

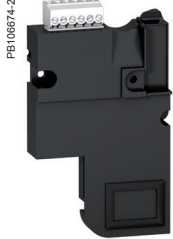

IO module

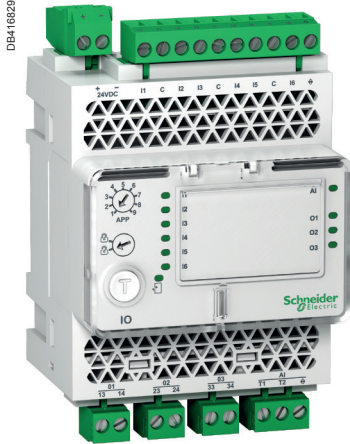

Communication options

For fixed and drawout devices, the common communication option is made up of:

- a BCM ULP module, which is installed behind the Micrologic control unit, is supplied with its set of sensors (OF, SDE, PF and CH micro switches), kit for connection to XF and MX1 communicating voltage releases and COM terminal block (inputs E1 to E6). This module is independent of the control unit. It receives and transmits information on the communication network. An infra-red link transmits data between the control unit and the communication module.

Consumption: 30 mA, 24 V.

- IFM, the Modbus-SL interface for LV circuit breaker, is required for the network connection, contains the Modbus address (1 to 99) declared by the user via the two dials in front. It automatically adapts (baud rate, parity) to the Modbus network in which it is installed.

or

- IFE, the Ethernet interface for LV breaker, enables an intelligent modular unit (IMU). For example, a Masterpact NT/NW or Compact NSX circuit breaker to be connected to an Ethernet network. Each circuit breaker has its own IFE and a corresponding IP address.

For drawout device, the Cradle Management option must be added:

IO input/output interface module for LV circuit breaker is delivered with withdrawable devices ordered with the COM option for cradle management. It must be installed on a DIN rail near the device. It must be connected to the ULP system and to the position contacts (CD, CT, CE) that transmit the position of the device in the cradle.

For communicating remote control, option with XF and MX1 communicating voltage releases must be added:

The XF and MX1 communicating voltage releases are equipped for connection to the "device" communication module.

The remote-tripping function (MX2 or MN) are independent of the communication option. They are not equipped for connection to the "device" communication module.

For more information on the communication option, refer to the:

- ULP system user guide
- IO module user guide
- IFE user guide

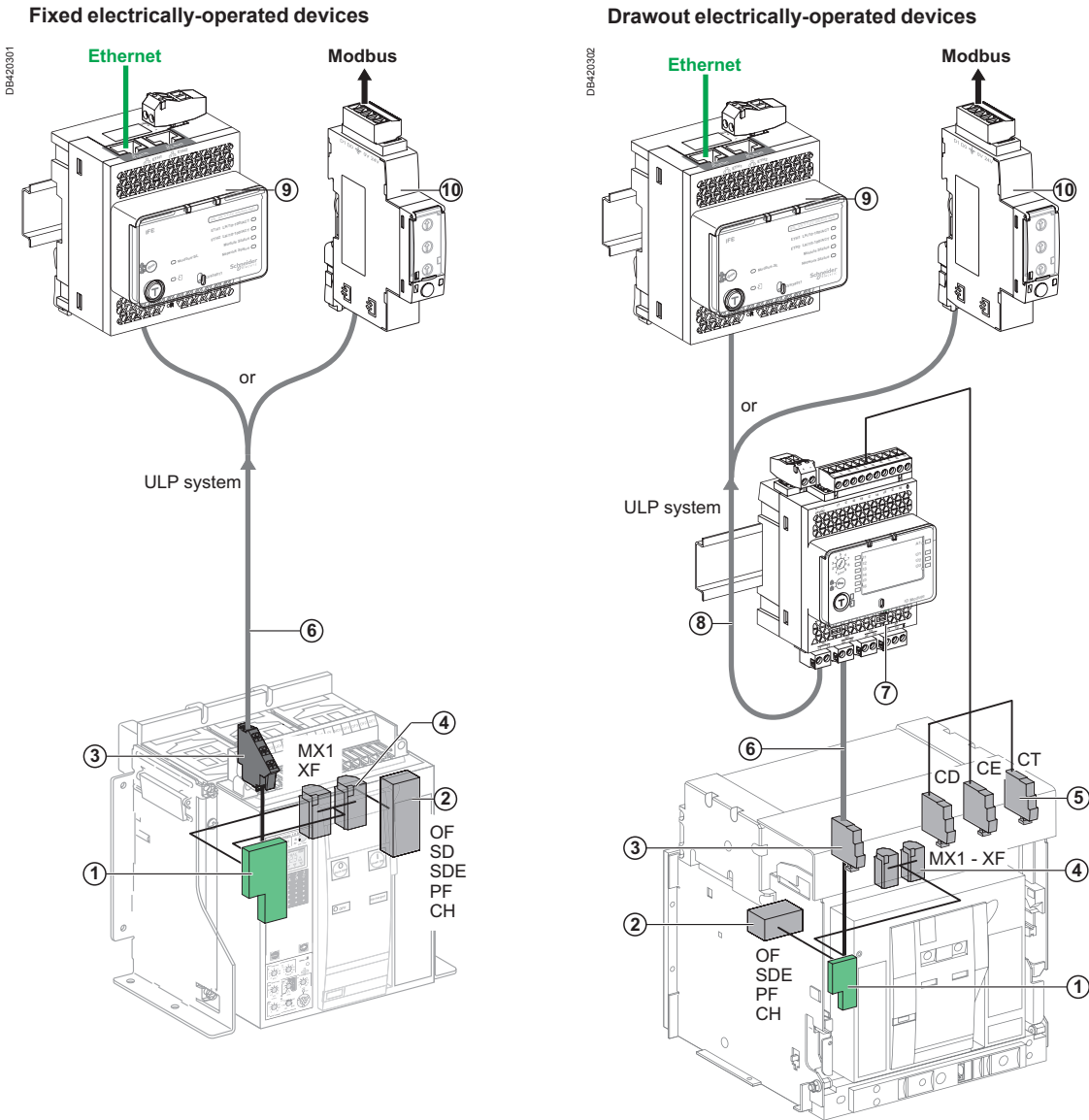

Optional M2C and M6C contacts

An alarm is issued if the Alarm or the Trip + Alarm mode was set for the given protection function.

Important

The M2C and M6C contacts require an auxiliary power supply. See the "Power supply" section in the technical appendix.

Wiring diagram for M2C contacts.

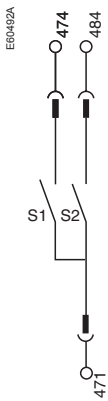

Wiring diagram for M6C contacts

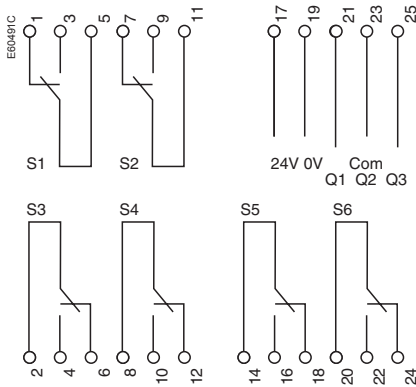

- Available types of contacts:
 - M2C: up to two contacts maximum, S1 and S2
 - M6C: up to six contacts maximum, S1 to S6.

- Current protection:
 - Ir
 - Isd
 - li
 - I_±
 - I_± Alarm
 - I unbal
 - I₁ max
 - I₂ max
 - I₃ max
 - I_N max.
- Voltage protection:
 - U min
 - U max
 - U unbal.
- Other protection:
 - F min
 - F max
 - rP max
 - phase rotation.

- Load shedding and reconnection:
 - current I
 - power P.
- Latching settings:
 - non-latching contact: the contact remains activated as long as the fault that caused the alarm has not been cleared
 - latching contact: the contact remains activated until it is reset ("Reset menu")
 - time-delay contact: the contact remains activated for the duration of an adjustable time delay or until it is reset ("Reset menu").
 - locked to 1: the contact is forced to 1 for an automation test
 - locked to 0: the contact is forced to 0 for an automation test.

■ Contact operating diagram for long-time protection

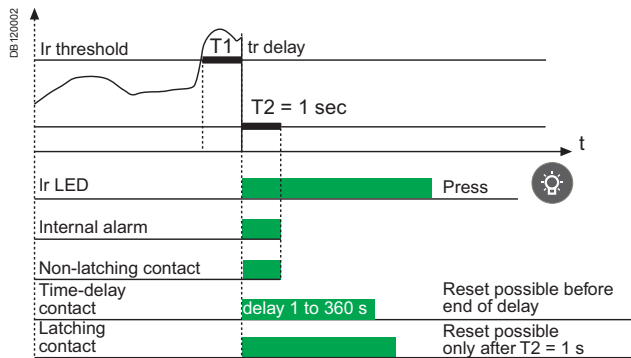

■ Contact operating diagram for short-time, instantaneous and ground-fault protection

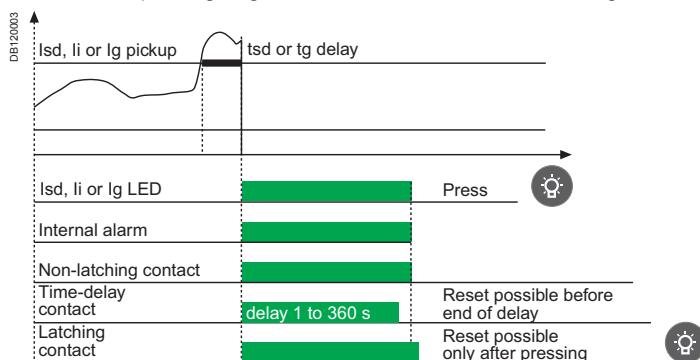

■ Contact operating diagram for the other protection functions

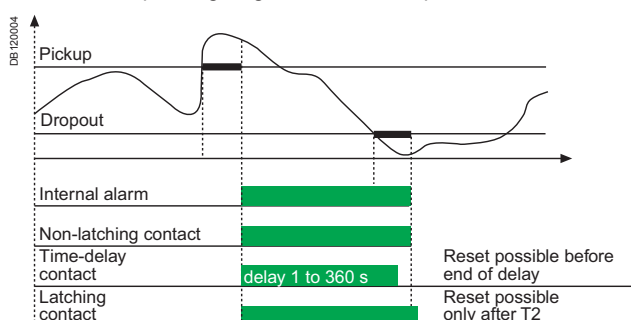



Setting up the optional M2C / M6C contacts

Select the command

 Contacts M2C / M6C

Alarm type

Select an alarm

Note:

An alarm may be selected if the "Alarm" or "Trip + Alarm" mode was selected during setup of the given protection function, in the "Protection" menu.

E71601A

Alarm type

S1

S2

E80146A



S2

Ir



E80226A

S2

Ir

  then 

Select a contact.

 then  

Select an alarm.



Confirm.

Select the command

 Contacts M2C / M6C

Setup

Set up each contact

- Select the latching mode

E71602A

Setup M2C / M6C

S1

S2

E71603A

S2

Mode



latching contact

E71604A



S2

Mode

latching contact

  then 

Select a contact.

 then  

Select a latching mode:

- non-latching
- latching
- time-delay
- locked to 1
- locked to 0.



Confirm.

Setting up the optional M2C / M6C contacts

■ Set the time delay for time-delay latching

S2

Mode
time delay

Delay

360s

S2

Mode
time delay

Delay

350s

S2

Mode
time delay

Delay

350s

then

Select the time delay.

Adjust.

Confirm.

Select the command

M2C / M6C
Contacts

Reset

Reset the contacts to 0

M2C / M6C

S1 0
S2 0

Reset (- / +)

M2C / M6C

S1 1
S2 1

Reset (- / +)

Reset the contacts to 0...

then

or cancel the reset,
then confirm.

Setting up the Micrologic control unit

Prior to setting up the protection functions or carrying out measurements, the following operations are required:

- selection of the display language
- entry of the date and time
- entry of the circuit-breaker type
- entry the power sign
- selection of the transformation ratio between the primary and secondary windings if an auxiliary voltage transformer is installed
- entry of the rated frequency.

Select the command

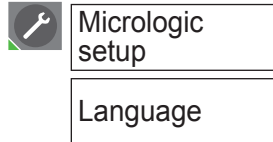

Select the display language



To return to English

1. Return to the main screen by pressing any of the three buttons



or press the button



followed by any of the three buttons



2. Select the "History, maintenance and setup" menu by pressing



3. Select the "Micrologic setup" menu by moving the cursor up on the first menu. Move the cursor down on the third menu and confirm by pressing



4. Select the "Language" menu by moving the cursor up on the first menu.

Confirm by pressing



Select the command

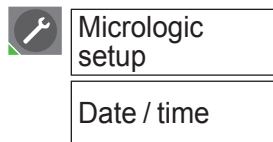

If the time is set via a communications module, any previous manual setting is automatically erased.

Set the date and time

- Enter the date and time for time-stamping purposes in the trip and alarm histories.

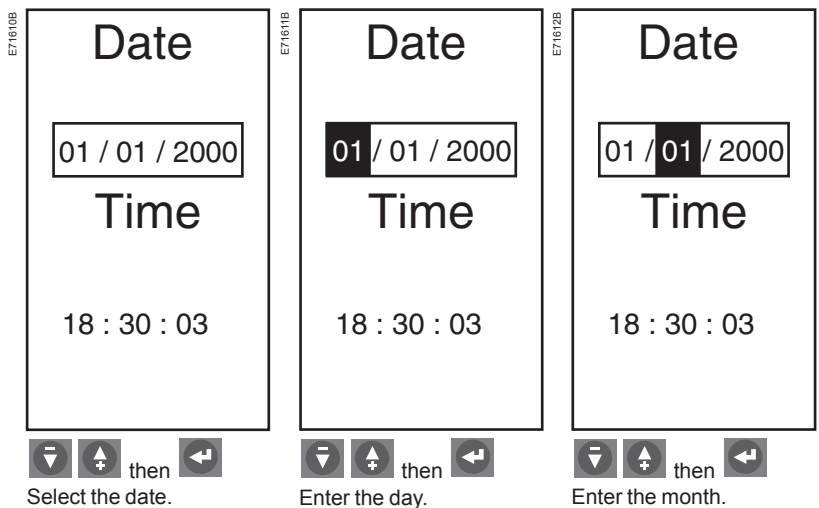

- The resolution of the time setting is 20 ms.

Setting up the Micrologic control unit

Date and time are backed up by battery.

If time is not synchronised by the supervisor via the communication module, a drift of up to one hour per year may be observed.

Date

01 / 01 / 2000

Time

18 : 30 : 03

↓ ↑ then ↩

Enter the year.

Date

01 / 01 / 2000

Time

18 : 30 : 03

↓ ↑ then ↩

Set the time in the same manner.

Select the command

Micrologic setup

Breaker selection

The circuit-breaker code is required to identify the device and activate the contact-wear counter.

Note this code if the control unit must be changed (example 03E7).

Enter this code when setting up a new control unit on the circuit breaker.
For a new device, the code is set to zero.



When the main circuit-breaker contacts are replaced, this code must be reset to zero.

Circuit-breaker selection

Breaker selection

Standard

UL

Circuit breaker

Masterpact

type

NT08N

0 3 E 7

P Logicxxxxxx

↓ ↑ then ↩

Select the standard.

Breaker selection

Standard

IEC

Circuit breaker

Masterpact

type

NT H1

0 3 E 7

P Logicxxxxxx

↓ ↑ then ↩

Choose and confirm.

Breaker selection

Standard

IEC

Circuit breaker

Masterpact

type

NT H1

0 3 E 7

P Logicxxxxxx

↓ ↑ then ↩

Select the circuit breaker.

Breaker selection

Standard

IEC

Circuit breaker

Compact NS

type

630b

0 3 E 7

P Logicxxxxxx

↓ ↑ then ↩

Choose and confirm.

Breaker selection

Standard

IEC

Circuit breaker

Compact NS

type

630b

0 3 E 7

P Logicxxxxxx

↓ ↑ then ↩

Select the type.

Breaker selection

Standard

IEC

Circuit breaker

Compact NS

type

800

0 3 E 7

P Logicxxxxxx

↓ ↑ then ↩

Choose and confirm.

Setting up the Micrologic control unit

Select the command

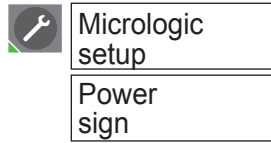

By default, Micrologic P uses P+ for the power flowing from top to bottom terminals. The selected direction of flow is valid for:

- measurement of power and the power factor
- measurement of energy
- load shedding and reconnection depending on power.

Select the command

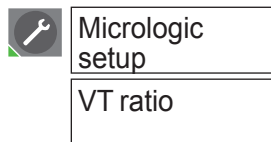

If the supply voltage for the control unit exceeds 690 V, an external voltage transformer must be installed.

To display the true voltage values, enter the transformation ratio between the primary and secondary voltages of the transformer.

Note that if Digipact display modules are used, the rated distribution-system voltage must be entered.

Select the command

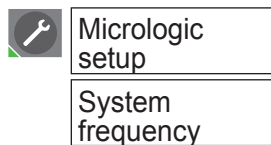

If the phase-rotation protection function is activated, the 400 Hz frequency may not be selected. If the 400 Hz frequency is selected, the phase-rotation protection function is disabled.

Select the sign of the power

E71642B

Power sign

Select.

E71643B

Power sign

Choose.

E71644B

Power sign

Confirm.

Enter the voltage-transformation ratio

E71624A

VT ratio

Primary

Secondary
690V

Select either the:
■ primary voltage
■ secondary voltage.

E71625A

VT ratio

Primary

Secondary
690V

Enter the voltage.

E71626A

VT ratio

Primary
690V

Secondary

Go on to the next setting.

Enter the rated frequency

E71627A

System frequency

Select.

E71628A

System frequency

Choose.

E71629A

System frequency

Confirm.

Setting up the metering functions

Prior to setting up the protection functions or carrying out measurements, the following operations are required:

- entry of the system type
- selection of the calculation mode for the demand current
- selection of the calculation mode for the demand power
- select the power sign
- select the sign convention for the power factor measurement.

Select the command

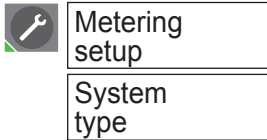

Important

The neutral current I_N cannot be measured with the "3-phase, 3-wire, 3-CT" and "3-phase, 4-wire, 3-CT" types.

For a 3-pole device, the neutral, if distributed, must be connected to terminal VN of the Micrologic P control unit.

See the "Overview of functions" section for information on the available types of measurements.

Select the system type

The Micrologic P control unit offers three measurement options:

- 3 phases, 3 wires, 3 CTs (method using two wattmeters)
The currents on phases I1, I2 and I3 are displayed.
The current on the neutral I_N is not displayed.
The phase-to-phase voltages U12, U23 and U31 are displayed.
The phase-to-neutral voltages V1N, V2N and V3N are not displayed.
- 3 phases, 4 wires, 3 CTs (method using three wattmeters)
The currents on phases I1, I2 and I3 are displayed.
The current on the neutral I_N is not displayed.
The phase-to-phase voltages U12, U23 and U31 are displayed.
The phase-to-neutral voltages V1N, V2N and V3N are displayed.
- 3 phases, 4 wires, 4 CTs (method using three wattmeters)
The currents on phases I1, I2 and I3 are displayed.
The current on the neutral I_N is displayed.
The phase-to-phase voltages U12, U23 and U31 are displayed.
The phase-to-neutral voltages V1N, V2N and V3N are displayed.

Note:

It is advised not to use the "3-phase, 4-wire, 4-CT" type of measurement unless the neutral is effectively connected to the control unit (four-pole circuit breaker with an external voltage-measurement input).

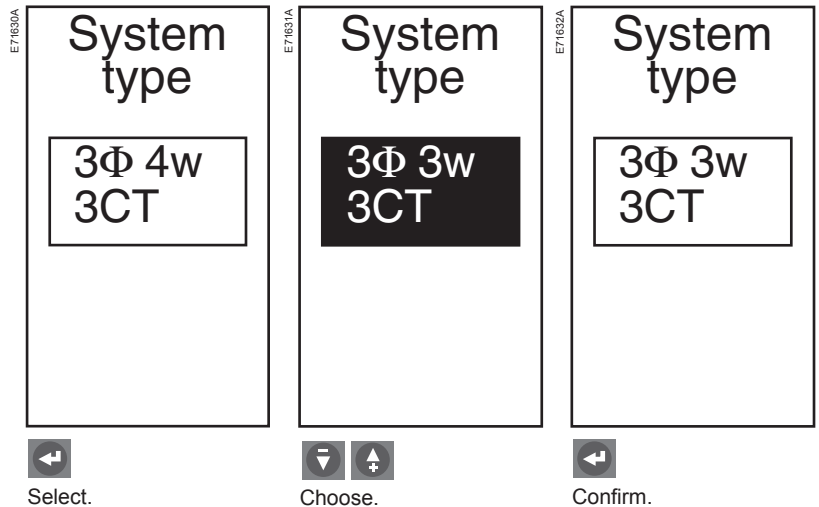

Select the command

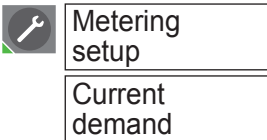

Thermal method based in I^2t calculation.

Select the calculation method for demand current

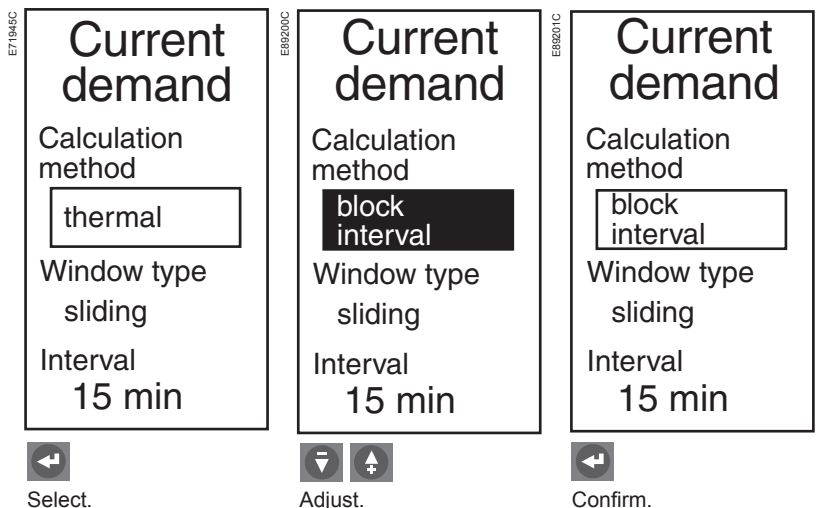

Setting up the metering functions

<p>EB9213C</p> <p>Current demand</p> <p>Calculation method block interval</p> <p>Window type sliding</p> <p>Interval <input type="text" value="15 min"/></p> <p>←</p> <p>Select.</p>	<p>EB9214C</p> <p>Current demand</p> <p>Calculation method block interval</p> <p>Window type sliding</p> <p>Interval <input type="text" value="20 min"/></p> <p>↓ ↑</p> <p>Adjust.</p>	<p>EB9215C</p> <p>Current demand</p> <p>Calculation method block interval</p> <p>Window type sliding</p> <p>Interval <input type="text" value="20 min"/></p> <p>←</p> <p>Confirm.</p>
---	---	--

Select the command

	Metering setup
	Power demand

The synchronisation function "Synchro.Com" is available only with the COM communication option. With this function, the demand power is determined on the basis of a signal synchronised by the communication module.

Thermal method based on I²t calculation.

Sliding window:
power demand is refreshed every 15 secondes.



Fixed window:
power demand is refreshed at the end of the time interval.

Select the calculation method for demand power

<p>EB9216C</p> <p>Power demand</p> <p>Calculation method <input type="text" value="thermal"/></p> <p>Window type sliding</p> <p>Interval 15 min</p> <p>↓</p> <p>Select.</p>	<p>EB9217C</p> <p>Power demand</p> <p>Calculation method block interval</p> <p>Window type sliding</p> <p>Interval 15 min</p> <p>↓ ↑</p> <p>Choose between: <input checked="" type="checkbox"/> thermal <input checked="" type="checkbox"/> block interval <input checked="" type="checkbox"/> sync. to comms</p>	<p>EB9218C</p> <p>Power demand</p> <p>Calculation method block interval</p> <p>Window type sliding</p> <p>Interval 15 min</p> <p>←</p> <p>Confirm.</p>
--	---	---

<p>EB9219C</p> <p>Power demand</p> <p>Calculation method block interval</p> <p>Window type <input type="text" value="sliding"/></p> <p>Interval 15 min</p> <p>←</p> <p>Select.</p>	<p>EB9220C</p> <p>Power demand</p> <p>Calculation method block interval</p> <p>Window type fixed</p> <p>Interval 15 min</p> <p>↓ ↑</p> <p>Choose between fixed or sliding.</p>	<p>EB9221C</p> <p>Power demand</p> <p>Calculation method block interval</p> <p>Window type fixed</p> <p>Interval 15 min</p> <p>←</p> <p>Confirm.</p>
---	---	---

Setting up the metering functions

<small>E86222C</small> Power demand Calculation method block interval Window type fixed Interval <input type="text" value="15 min"/>	<small>E86223C</small> Power demand Calculation method block interval Window type fixed Interval <input type="text" value="20 min"/>	<small>E86320A</small> Power demand Calculation method block interval Window type fixed Interval <input type="text" value="20 min"/>
 Select.	 Adjust.	 Confirm.



Select the command

 Metering setup

Sign convention

See page 87 for the description of power factor sign conventions.

Set up the power-factor calculation

<small>E89226B</small> Sign convention <input type="text" value="IEEE"/>	<small>E89228B</small> Sign convention <input type="text" value="IEEE alt."/>	<small>E89227B</small> Sign convention <input type="text" value="IEEE alt."/>
 Select.	 Choose between IEEE, IEEE alternate and IEC.	 Confirm.

Setting up the COM communications option

Select the command

Com. setup

Com. parameter

As soon as the communications option is connected, the control unit recognises it and displays the type of module on the graphic screen. Automatic time updates are possible only with the Modbus system.

When a COM communications option is used, it is necessary to:

- set up the COM communications option
- authorise remote setting of the Micrologic control unit
- authorise remote control of the circuit breaker.

Set up the Modbus address

The setting of the Modbus address depends on the COM option.

COM option	Modbus address	Modbus address range
BCM or BCM ULP not connected to IFM or IFE	The Modbus address is set up on the Modbus Com setting screen, with the parameters of the communication option (see below).	1 to 47
BCM ULP connected to IFM	The Modbus address is set up on the 2 address rotary switches on the front panel of the IFM.	1 to 99 Value 0 is forbidden because it is reserved for broadcasting messages.
BCM ULP connected to IFM with legacy firmware	The Modbus address is set up on the 2 address rotary switches on the front panel of the IFM.	1 to 47 Value 0 is forbidden because it is reserved for broadcasting messages. Values 48 to 99 are not allowed.
BCM ULP connected to IFE	The Modbus address is fixed and cannot be changed.	255

View and set up the communications option

E71723A

Modbus Com

Address

47

Baud-rate

9600

Parity

None

Connection

2Wires+ULP

then

Select an existing parameter.

E71723A

Modbus Com

Address

45

Baud-rate

9600

Parity

None

Connection

2Wires+ULP

Adjust.

E71725A

Modbus Com

Address

45

Baud-rate

9600

Parity

None

Connection

2Wires+ULP

Confirm.

DB420303

Modbus Com

Address

47

Baud-rate

9600

Parity

None

Connection

2Wires+ULP

then

Select an existing setting.

DB420304

Modbus Com

Address

47

Baud-rate

9600

Parity

None

Connection

4Wires

Choose.

DB420305

Modbus Com

Address

47

Baud-rate

9600

Parity

None

Connection

4Wires

Confirm.

Setting up the COM communications option

Select the command

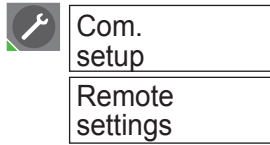

The access code is a password that must be provided by the supervisor prior to accessing the Micrologic settings.

If the operator does not enter a specific access code, the default access code is 0000 and is requested by the supervisor.

Authorise remote setup of Micrologic

To authorise the remote setup of the Micrologic control unit equipped with a BCM or BCM ULP, access permit must be set to YES on the Remote settings screen.

Three sequential screenshots of the 'Remote settings' screen:

- Screen 1 (E71726A):** 'Access permit' is set to 'No'. Below it, 'Access code' is '0 0 0 0'. Navigation: Down arrow, Up arrow, then Left arrow.
- Screen 2 (E71727A):** 'Access permit' is set to 'Yes' (highlighted in black). 'Access code' is '0 0 0 0'. Navigation: Down arrow, Up arrow.
- Screen 3 (E71728A):** 'Access permit' is 'Yes' and 'Access code' is '0 0 0 0'. Navigation: Left arrow.

Labels below the screens: 'Select existing setting.', 'Choose.', 'Confirm.'

If the BCM or BCM ULP is connected to an IFM or IFE communication interface, the IFM or IFE locking pad must be set to UNLOCK (padlock open).

Three sequential screenshots of the 'Remote settings' screen:

- Screen 1 (E71728A):** 'Access permit' is 'Yes' and 'Access code' is '0 0 0 0'. Navigation: Left arrow.
- Screen 2 (E71730A):** 'Access permit' is 'Yes' and 'Access code' is '1 0 0 0'. Navigation: Down arrow, Up arrow.
- Screen 3 (E71731A):** 'Access permit' is 'Yes' and 'Access code' is '1 0 0 0'. Navigation: Left arrow.

Labels below the screens: 'Select the existing access code setting.', 'Enter the first digit.', 'Confirm and proceed in the same manner for the other digits.'

Setting up the COM communications option

Select the command

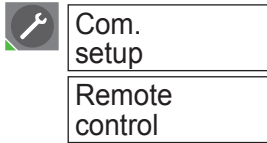

It is possible to set circuit-breaker control to local only ("Manual") or to local and remote ("Auto").

Authorise remote control of the circuit breaker

To authorise the remote control of the circuit breaker, Auto must be set on the Remote control screen.

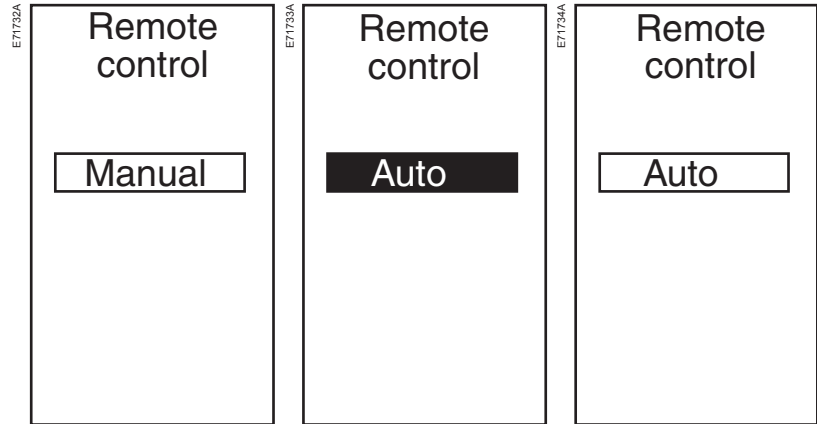

Press enter.



Select Auto or Manual.



Confirm.

If the circuit breaker is connected to other ULP modules, each ULP module must be set to authorise the remote control of the circuit breaker:

- On FDM121 display unit, set the circuit breaker in remote control mode on the FDM121 Control menu
- On IO module with predefined application 2 (breaker application), set the selector switches connected to the IO module inputs to:
 - Remote control mode (I1 = 1)
 - Enable close order (I4 = 1)
- On IFM or IFE communication interface, the IFM or IFE locking pad must be set on UNLOCK (padlock open).

For more information on the communication option, refer to the:

- ULP system user guide
- IO module user guide
- IFE user guide
- FDM121 user guide



Fine adjustment of the long-time I^2t , short-time and Instantaneous settings using the keypad

Select the command.

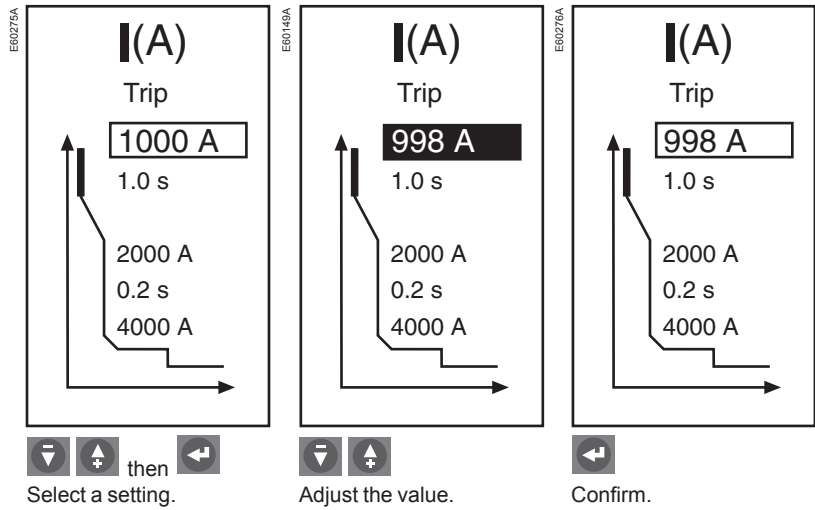
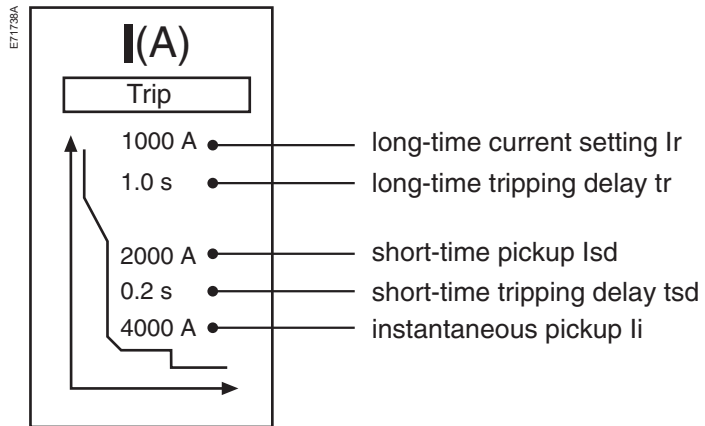
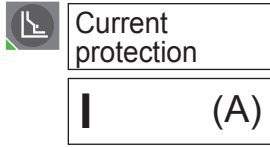

When all the settings have been adjusted, quit the screen by pressing one of the menu-access buttons. This saves the new values.

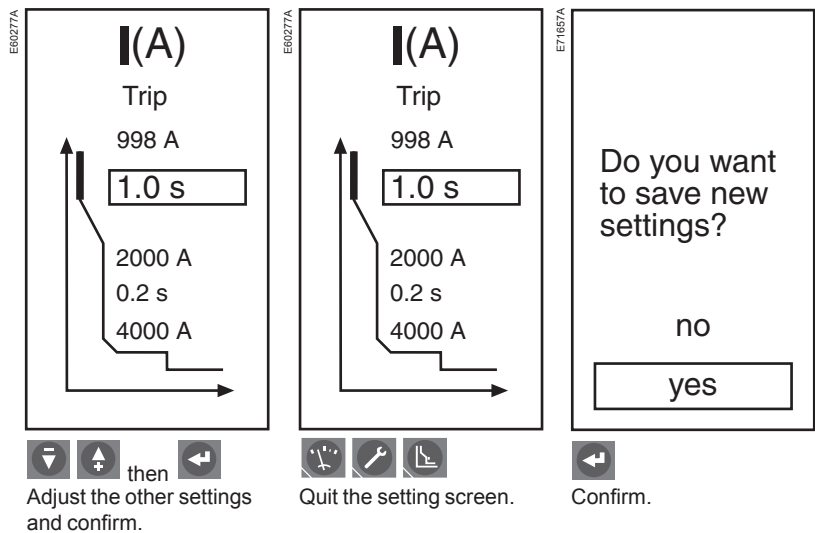

Fine adjustment of the long-time Idmtl, short-time and instantaneous settings using the keypad

Select the command

Current protection

Idmtl (A)

Idmtl (A)

Trip
 1000 A ● long-time current setting I_r
 1.0 s ● long-time tripping delay t_r
EIT ● Idmtl protection: DT, SIT, VIT, EIT, HVF
 2000 A ● short-time pickup I_{sd}
 0.2 s ● short-time tripping delay t_{sd}
 4000 A ● instantaneous pickup I_i

Idmtl (A)

Change I(A) settings with Idmtl(A)?

No

Yes

↓ ↑ then ←
Select yes.

Idmtl (A)

Trip
 1000 A
 1.0 s
EIT
 2000 A
 0.2 s
 4000 A

↓ ↑ then ←
Select a setting.

Idmtl (A)

Trip
 1000 A
 1.0 s
VIT
 2000 A
 0.2 s
 4000 A

↓ ↑
Change the setting.

Idmtl (A)

Trip
 1000 A
 1.0 s
VIT
 2000 A
 0.2 s
 4000 A

←
Confirm.

Idmtl (A)

Trip
 1000 A
1.0 s
 VIT
 2000 A
 0.2 s
 4000 A

↓ ↑ then ←
Adjust the other settings.

Do you want to save new settings?

no

yes

←
Confirm.

Fine adjustment of the ground-fault and earth-leakage protection setting using the keypad

Select the command

Current protection

$I_{\Delta}(A)$ (A)

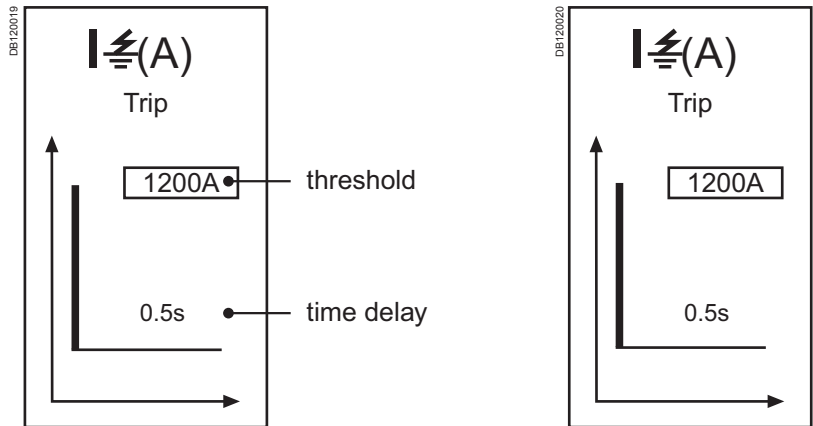

↓ ↑ then ←
Select a setting.

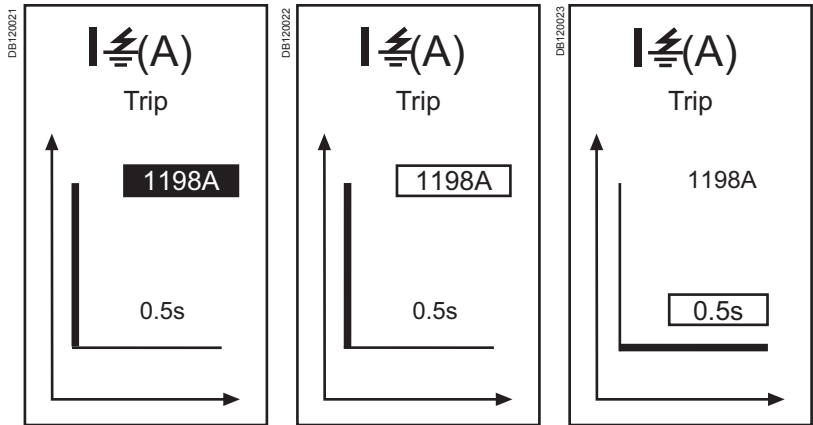

↓ ↑

Adjust the value.

←

Confirm.

↓ ↑ then ←

Go to the next setting.

When all the settings have been adjusted, quit the screen by pressing one of the menu-access buttons. This saves the new values.

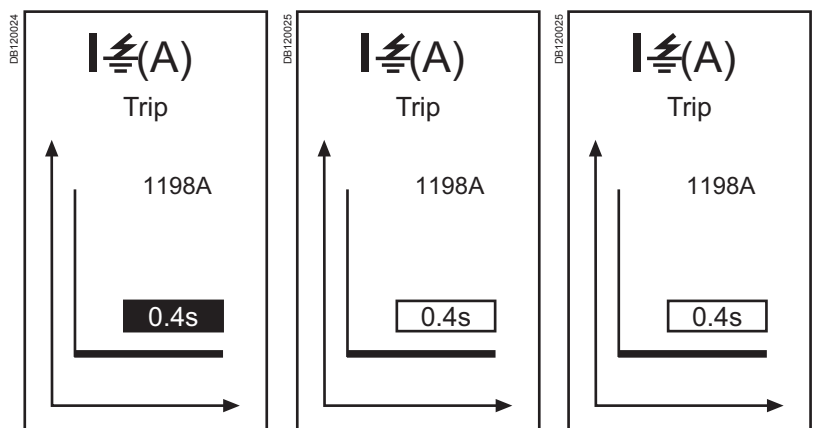

↓ ↑

Adjust the value.

←

Confirm.

⌂ ⚙ ⏪

Quit the setting screen.

Select the command

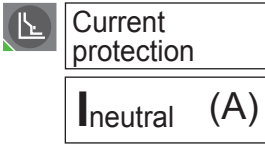

Important

Selection of the CT type determines the "Neutral" protection in the "Protection" menu.

- "none" disables the neutral protection.
- "Internal" for a four-pole circuit breaker provides access to the N/2, N and OFF protection functions.
- "External" for a three-pole circuit breaker provides access to the N/2, N, 1.6xN and OFF protection functions.

Using the keypad on the control unit

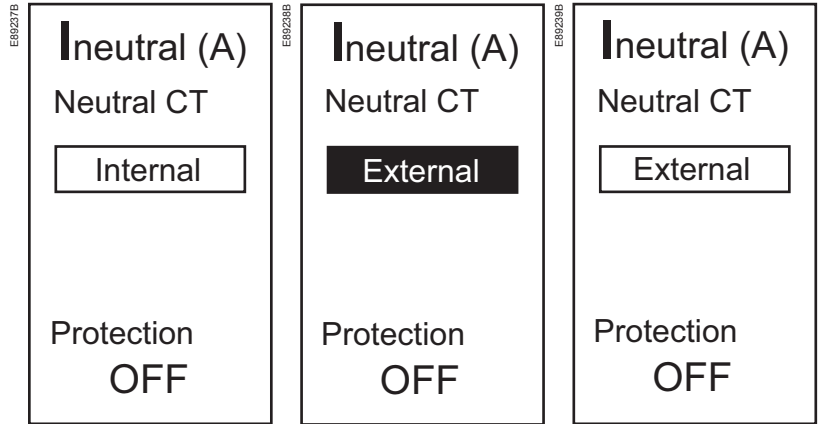

then Select.

Choose between:
 internal
 external
 none.

Confirm.

Type of circuit breaker	Possible choices
Four-pole	OFF: no neutral protection N / 2: half neutral protection N: full neutral protection
Three-pole	OFF: no neutral protection N / 2: half neutral protection N: full neutral protection 1.6 x N: oversized neutral protection

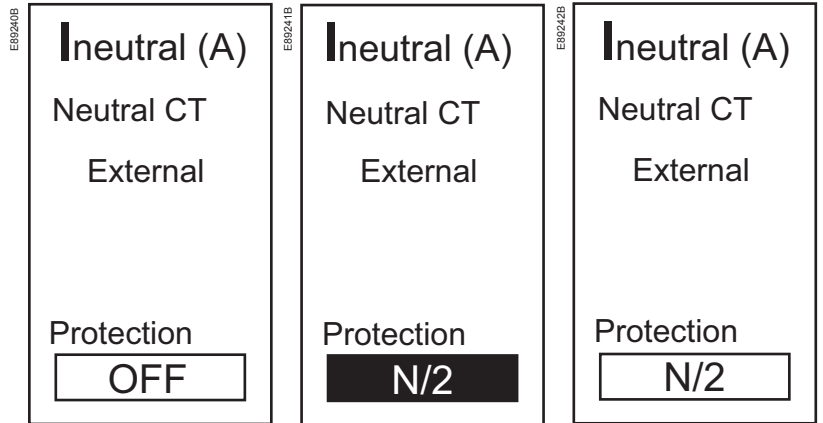

then Select.

Choose.

Confirm.

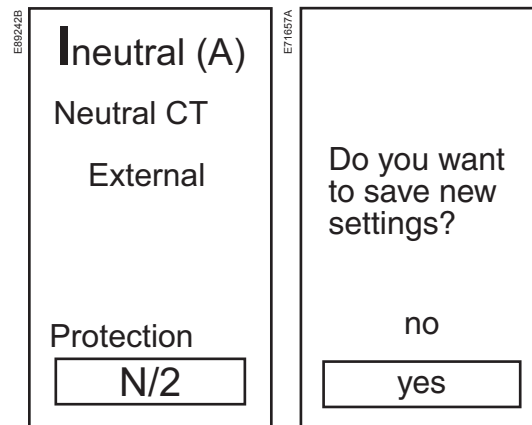

Quit the setting screen.

Confirm.

Note:

On four-pole circuit breakers, setting of the neutral using the keypad is limited by the dial setting.

Setting the I_{\neq} , I_{unbal} , \bar{I}_{max} , U_{min} , U_{max} , U_{unbal} , rP_{max} , F_{min} , F_{max} , and phase-rotation protection functions using the keypad

Select the corresponding menu

Current protection

- I_{\neq} Alarm
- I_{unbal} (%)
- \bar{I}_1 max (A)
- \bar{I}_2 max (A)
- \bar{I}_3 max (A)
- \bar{I}_N max (A)

Voltage protection

- U_{min} (V)
- U_{max} (V)
- U_{unbal} (%)

Other protection

- rP_{max} (W)
- F_{min} (Hz)
- F_{max} (Hz)
- Phase rotation

In trip mode, the dropout threshold is equal to the pickup threshold.
The dropout time delay is fixed and equal to 1 second.

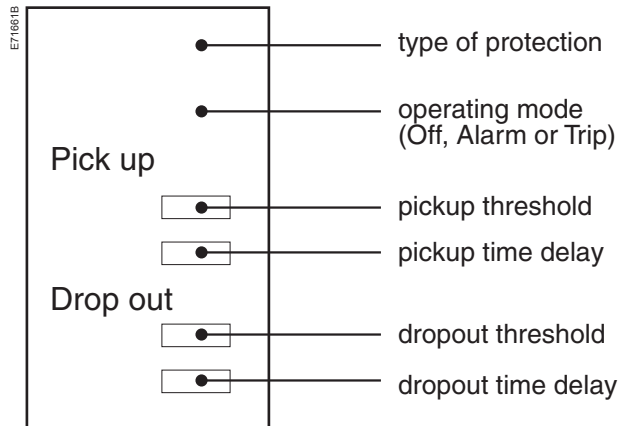

Specific case for I_{\neq} alarm

- Only the following choices are available:
- On: activation of the alarm without fault tripping by the circuit breaker
- Off: alarm disabled.

Example: Maximum voltage setting (U_{max})

■ Select Alarm mode

U_{max} (V)

Off

Pick up

690V
5.00s

Drop out

690V
0.50s

U_{max} (V)

Alarm

Pick up

690V
5.00s

Drop out

690V
0.50s

U_{max} (V)

Alarm

Pick up

690V
5.00s

Drop out

690V
0.50s

Select the first setting.

Choose Off or Alarm.

Confirm.

U_{max} (V)

Off

Pick up

690V
5.00s

Drop out

690V
0.50s

U_{max} (V)

Trip

Pick up

690V
5.00s

Select the first setting.

Choose Trip.

Setting the I_{\neq} , I_{unbal} , I_{max} , U_{min} , U_{max} , U_{unbal} , rP_{max} , F_{min} , F_{max} , and phase-rotation protection functions using the keypad

U_{max} (V)

Do you want to set the protection to Trip mode?

no

yes

U_{max} (V)

Trip

Pick up

690V

5.00s

then

Confirm.

For protection tripped by a maximum value, the dropout threshold is always less than or equal to the pickup threshold.

For protection tripped by a minimum value, the dropout threshold is always greater than or equal to the pickup threshold.

If both the minimum and maximum protection values are activated, the minimum threshold is automatically limited to the value of the maximum and vice versa.

■ Set the pickup and dropout thresholds and time delays

U_{max} (V)

Alarm

Pick up

690V

5.00s

Drop out

690V

0.50s

U_{max} (V)

Alarm

Pick up

690V

5.00s

Drop out

685V

0.50s

U_{max} (V)

Alarm

Pick up

690V

5.00s

Drop out

685V

0.50s

then

Select the existing dropout threshold setting

Adjust.

Confirm.

When all the settings have been made, quit the screen by pressing one of the menu-access buttons. This saves the new values.

U_{max} (V)

Alarm

Pick up

690V

5.00s

Drop out

685V

0.50s

U_{max} (V)

Alarm

Pick up

690V

5.00s

Drop out

685V

0.50s

Do you want to save new settings?

no

yes

then

Set the other parameters.

Quit the setting screen.

Confirm

Setting load shedding / reconnection

Select the command



Load shedding I

Load shedding P

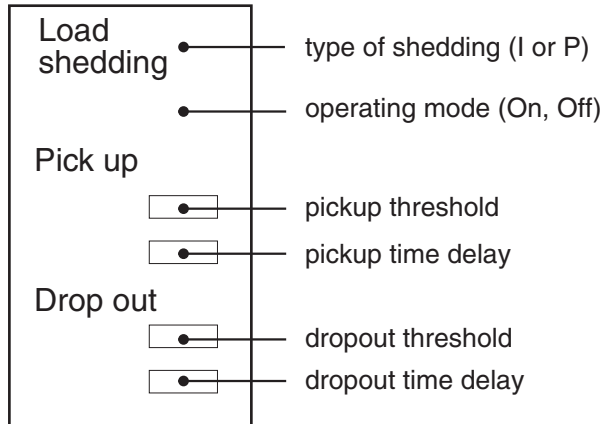

E716729B





Setting load shedding / reconnection

Example: Take load shedding / reconnection depending on power.



E71670A	Load shedding P <input type="text" value="Off"/> Pick up 1000kW 3600s Drop out 1000kW 10s	E71671A	Load shedding P <input checked="" type="text" value="On"/> Pick up 1000kW 3600s Drop out 1000kW 10s	E71672A	Load shedding P <input type="text" value="On"/> Pick up 1000kW 3600s Drop out 1000kW 10s
---------	---	---------	---	---------	--

  then 
Select the first setting.

 
Select:
 Off: load shedding disabled
 On: load shedding enabled.

Confirm.

E71674A	Load shedding P On Pick up 1000kW 3600s Drop out <input type="text" value="980kW"/> 10s	E71675A	Load shedding P On Pick up 1000kW 3600s Drop out <input checked="" type="text" value="985kW"/> 10s	E71676A	Load shedding P On Pick up 1000kW 3600s Drop out <input type="text" value="985kW"/> 10s
---------	---	---------	--	---------	---

  then 
Select the existing dropout threshold.

 
Adjust.

Confirm.

When all the settings have been made, quit the screen by pressing one of the menu-access buttons. This saves the new values.

E71677A	Load shedding P On Pick up 1000kW 3600s Drop out 985kW <input type="text" value="10s"/>	E71677A	Load shedding P On Pick up 1000kW 3600s Drop out 985kW <input type="text" value="10s"/>	E71657A	Do you want to save new settings? no <input type="text" value="yes"/>
---------	---	---------	---	---------	---

  then 
Set the other parameters.

  
Quit the setting screen.



Confirm.

Only the measurements for the phase (1, 2, 3) and neutral currents are displayed on the main screen.

The neutral current is displayed if the neutral CT is set to internal or external (see "Neutral (A)" settings in the "Current protection" menu).

Continuous current measurement

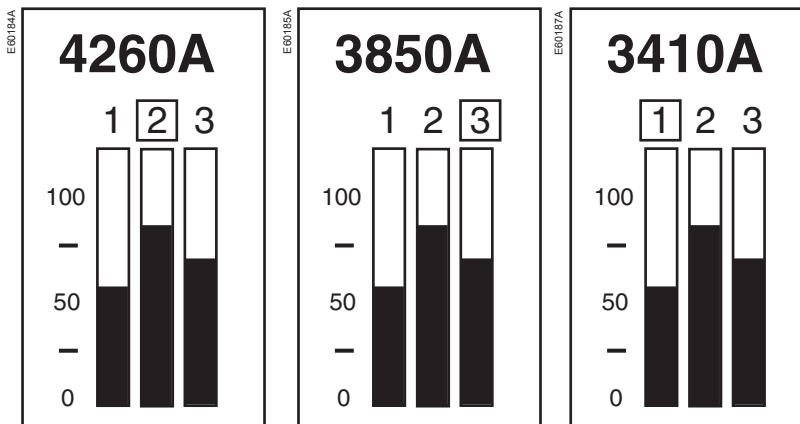
The bargraph displays the value in amperes of the most heavily loaded phase.



The and buttons may be used to display the currents on the three phases. If the operator no longer uses the buttons for a few seconds, the bargraph returns to the display of the most heavily loaded phase.

Select the command

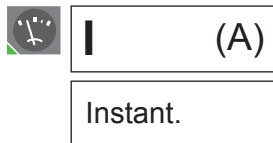

Measure an instantaneous-current value

■ Measure the instantaneous currents

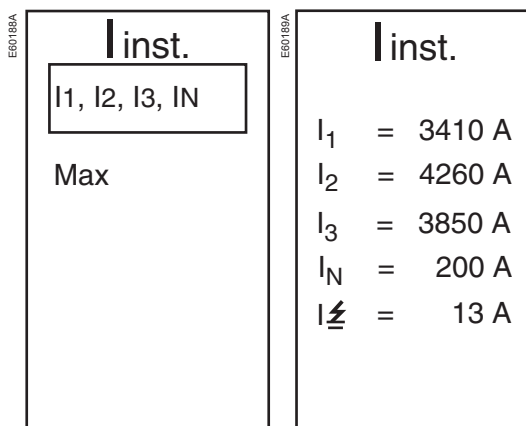

Select.

View.

■ Check the instantaneous-current maximeter

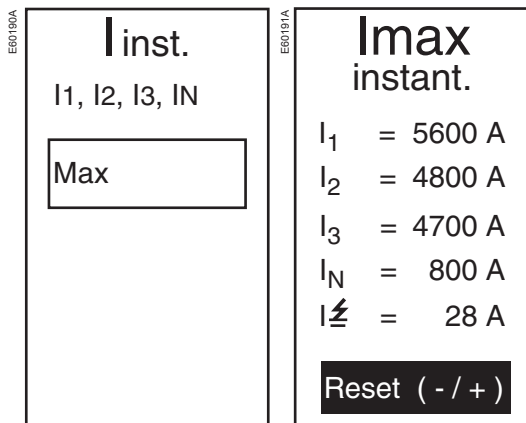

Select.

View.

■ Reset the maximeter

E60192A

I_{max}
instant.

$I_1 = 0\text{ A}$

$I_2 = 0\text{ A}$

$I_3 = 0\text{ A}$

$I_N = 0\text{ A}$

$I_{\Sigma} = 0\text{ A}$

Reset (- / +)

E60191A

I_{max}
instant.

$I_1 = 5600\text{ A}$

$I_2 = 4800\text{ A}$

$I_3 = 4700\text{ A}$

$I_N = 800\text{ A}$

$I_{\Sigma} = 28\text{ A}$

Reset (- / +)



Reset the maximeter or...



cancel the reset.

Select the command



I (A)

Demand.

■ Measure a demand-current value

■ Measure the demand currents

E771878A

Demand

$\bar{I}_1, \bar{I}_2, \bar{I}_3, \bar{I}_N$

Max

E771879A

Demand

13min

$\bar{I}_1 = 3950\text{ A}$

$\bar{I}_2 = 4270\text{ A}$

$\bar{I}_3 = 3890\text{ A}$

$\bar{I}_N = 340\text{ A}$



then



View.

■ Check the demand-current maximeter

Demand

$\bar{I}_1, \bar{I}_2, \bar{I}_3, \bar{I}_N$

Max

I_{max}

Demand

15min

$\bar{I}_1 = 4020 \text{ A}$

$\bar{I}_2 = 4450 \text{ A}$

$\bar{I}_3 = 4300 \text{ A}$

$\bar{I}_N = 600 \text{ A}$

Reset (- / +)



Select.

View.

■ Reset the maximeter

I_{max}

Demand

15min

$\bar{I}_1 = 0 \text{ A}$

$\bar{I}_2 = 0 \text{ A}$

$\bar{I}_3 = 0 \text{ A}$

$\bar{I}_N = 0 \text{ A}$

Reset (- / +)

I_{max}

Demand

15min

$\bar{I}_1 = 4020 \text{ A}$

$\bar{I}_2 = 4450 \text{ A}$

$\bar{I}_3 = 4300 \text{ A}$

$\bar{I}_N = 600 \text{ A}$

Reset (- / +)



Reset the maximeter or...



cancel the reset.

Select the command



The phase-to-neutral voltages are displayed if the selected system type is 3-phase, 4-wire (see page 43).

Measure an instantaneous-voltage value (U or V)

<p>EB92479B</p> <p style="text-align: center;">U (V)</p> <p>Instant.</p> <p>Average 3Φ</p> <p>Unbal 3Φ</p> <p>Phase rotation</p>	<p>EG0193A</p> <p style="text-align: center;">U_{inst.}</p> <p>U₁₂ = 400 V</p> <p>U₂₃ = 404 V</p> <p>U₃₁ = 401 V</p> <p>U_{1N} = 230 V</p> <p>U_{2N} = 229 V</p> <p>U_{3N} = 233 V</p>
---	---



Select.

View.

Measure the average voltage U avg

<p>EB9258B</p> <p style="text-align: center;">U (V)</p> <p>Instant.</p> <p>Average 3Φ</p> <p>Unbal 3Φ</p> <p>Phase rotation</p>	<p>E71687A</p> <p style="text-align: center;">U_{avg.} 3Φ</p> <p style="text-align: center;">402 V</p>
--	---



Select.

View.

Measure the voltage unbalance U unbal

<p>EB9259B</p> <p style="text-align: center;">U (V)</p> <p>Instant.</p> <p>Average 3Φ</p> <p>Unbal 3Φ</p> <p>Phase rotation</p>	<p>E71688A</p> <p style="text-align: center;">U_{unbal} 3Φ</p> <p style="text-align: center;">1 %</p>
--	--



Select.

View.

Determine the phase sequence

The screenshot shows a control panel for voltage measurements. On the left, a vertical label 'E1B260A' is positioned next to a box containing the following options: 'U (V)', 'Instant.', 'Average 3Φ', 'Unbal 3Φ', and 'Phase rotation'. The 'Phase rotation' option is highlighted with a rectangular border. On the right, another vertical label 'E1B261A' is next to a box containing 'Phase rotation' and 'ΔΦ: 1, 2, 3'.



Select.

View.

Select the command

 **P** (kW)
Instant.

To ensure reliable power and power-factor measurements, the "Power sign" and "Sign convention" parameters must be set.

Measure an instantaneous-power value

E71680A

Pinst.

P, Q, S

Power factor

E60198B

Pinst.

P	(kW) 2180
Q	(kvar) -650
S	(kVA) 2280

  then 
Select. View.

Measure the power factor

E71681A

Pinst.

P, Q, S

Power factor

E71682A

Power factor

1.00

  then 
Select. View.

Select the command

 **P** (kW)
Demand

Measure a demand-power value

■ Display the demand power

E71683A

Demand

$\bar{P}, \bar{Q}, \bar{S}$

Max

E71684B

Demand

\bar{P}	(kW) 2350
\bar{Q}	(kvar) -820
\bar{S}	(kVA) 2640

  then 
Select. View.

■ Check the demand-power maximeter

Demand

\bar{P} , \bar{Q} , \bar{S}

Max

Pmax
Demand

\bar{P} (kW)
2450

\bar{Q} (kvar)
-800

\bar{S} (kVA)
2700

Reset (- / +)



Select.

View.

■ Reset the maximeter

Pmax
Demand

\bar{P} (kW)
0

\bar{Q} (kvar)
0

\bar{S} (kVA)
0

Reset (- / +)

Pmax
Demand

\bar{P} (kW)
2450

\bar{Q} (kvar)
-800

\bar{S} (kVA)
2700

Reset (- / +)



Reset the maximeter or...



cancel the reset.

Select the command



To ensure reliable energy measurements, the "Power sign" and "Sign convention" parameters must be set.

Measure the energy values

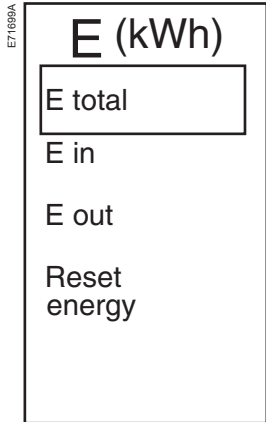

Select the energy value to be measured:

- total energy
- energy in (positive component in the total energy)
- energy out (negative component in the total energy).



Select.

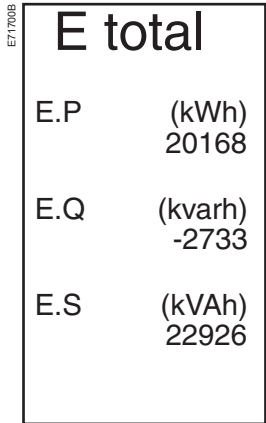

View the total energy values.

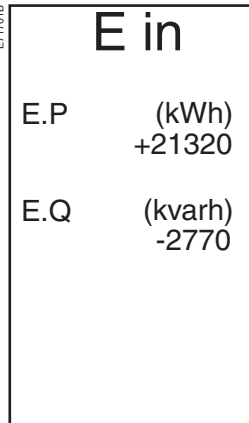

View the energy in values.

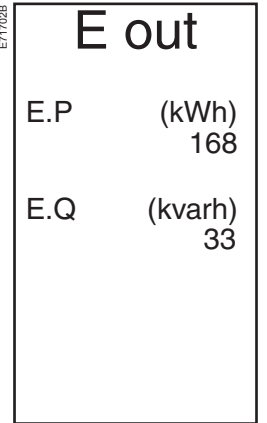

View the energy out values.

Reset the energy values

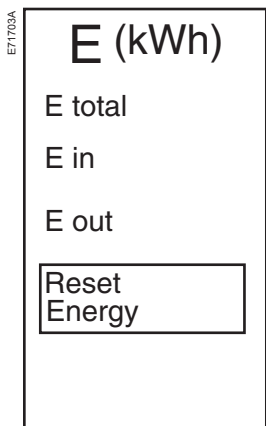

Select.

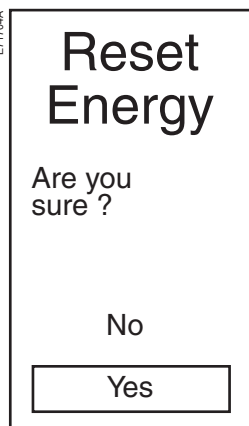

Select yes or no.

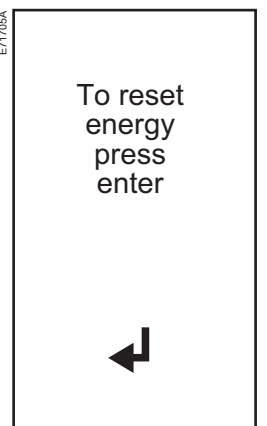

If yes, confirm.

Select the command



F (Hz)

EG010A

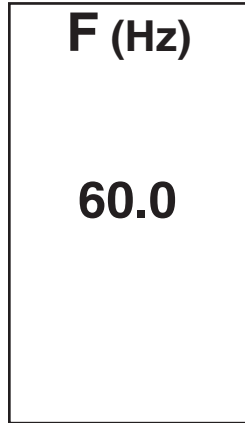

View.



Important

If the circuit breaker remains closed and the Ap LED remains ON after the reset, open the circuit breaker and contact the after-sales support department.

The fault indication is maintained until it is reset on the control panel.
Press the reset button.

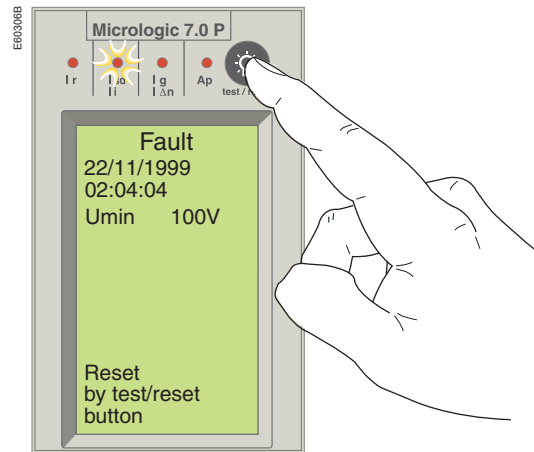

Select the command



Event history

Trip history

Trip history

E71708A

Trip history

U min
27/01/1999

Ir
27/06/1998

Ir
18/02/1998



Select a fault.

E71707A

Trip

22/11/1999
02:04:04
Umin 160V

View.

Select the command



Event history

Alarm history

Alarm history

E71708A

Alarm history

I2 max
27/01/1999

In max
23/03/1998

U max
12/02/1998



Select an alarm.

E71709A

Alarm

27/01/1999
13:06:09
I2 max 3400A

View.

Operation counter and contact-wear indicator

Select the command



Event history

Operation counter

View and/or reset the operation counter

E71735A

Number of operations

Total
17824

Operations since last reset
6923

Reset (- / +)

E71736A

Number of operations

Total
17824

Operations since last reset
0

Reset (- / +)

E71737A

Number of operations

Total
17824

Operations since last reset
6923

Reset (- / +)



Reset...



then ... or cancel the reset, then confirm.

Select the command



Event history

Contact wear

Check the wear of the contacts

E71710C

Contact wear

59

Contact wear is indicated from 0 to 900. The contacts should be inspected every time the counter reaches a multiple of 100.

Checking/replacing the battery

Check the control-unit battery

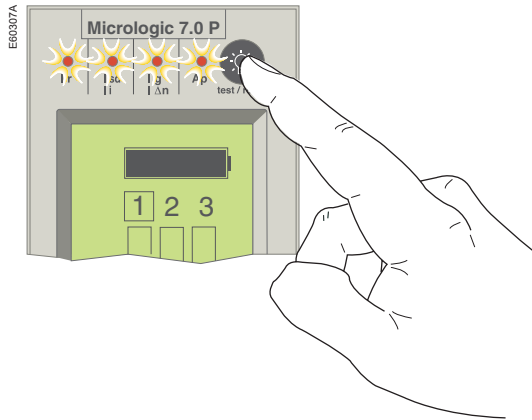

Press and hold down the test button on the control unit to check the LEDs and the battery. The battery information is displayed if the control unit is equipped with an external power supply or if the circuit breaker is ON.

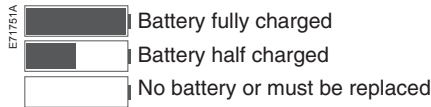

If the battery needs to be changed, order a new battery with the Schneider Electric catalogue number 33593.

- Lithium battery
- 1.2 AA, 3.6 V, 800 mA/h
- Ambient temperature: 130°C.

Replacing the control-unit battery

1. remove the battery cover
2. remove the battery

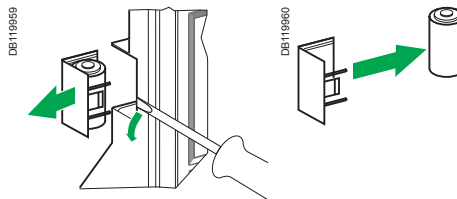

3. insert a new battery. Check the polarity.
4. put the cover back in place. Press the battery-test button to check the new battery.

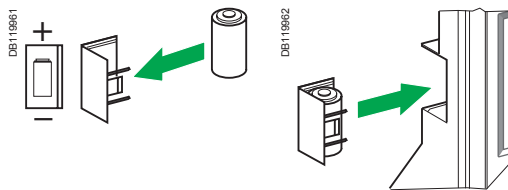

Test the ground-fault (Micrologic 6.0 P) and earth-leakage (Micrologic 7.0 P) protection functions

The circuit breaker must be supplied with power and closed for the test.

Press the TEST button. The circuit breaker should trip.

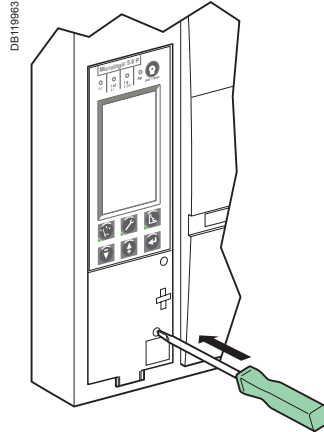

If the circuit breaker does not trip, contact the after-sales support department.

Refer to the manual that comes with the test kits.

Mini test kit and portable test kit

The test connector is used to connect the mini or the portable test kit to check that the control unit is operating correctly.

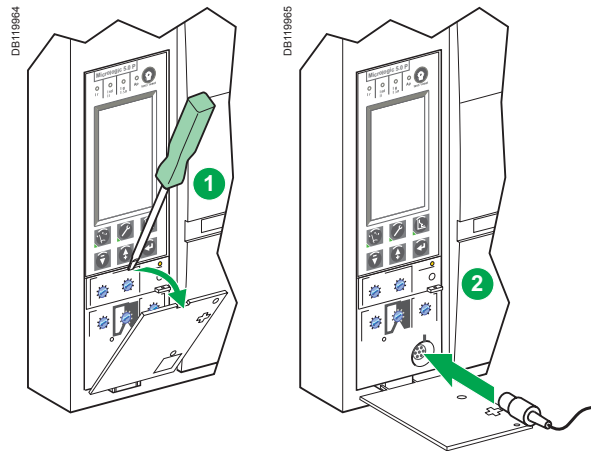



Tripping curves

Long-time I^2t , short-time and instantaneous protection Micrologic 5.0 P, 6.0 P, 7.0 P

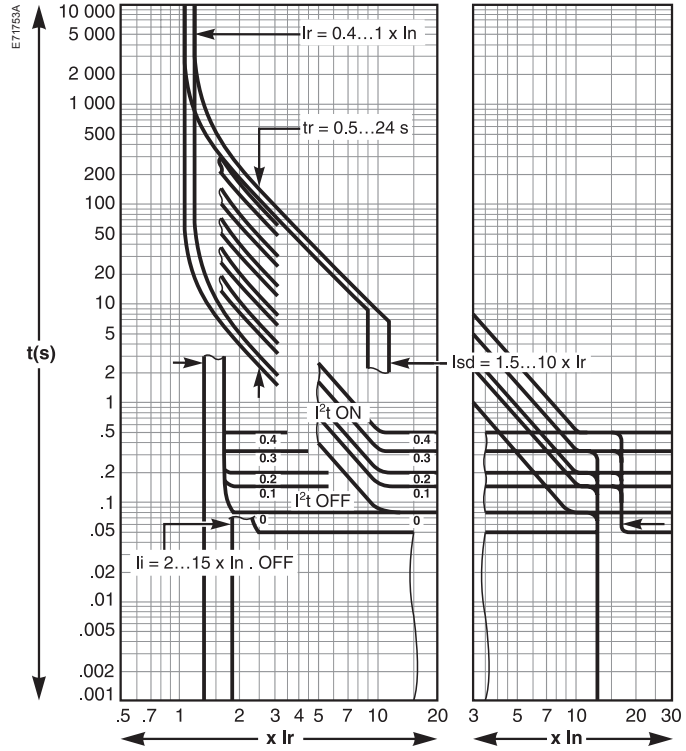

Long-time I_{dmtl} , short-time and instantaneous protection Micrologic 5.0 P, 6.0 P, 7.0 P

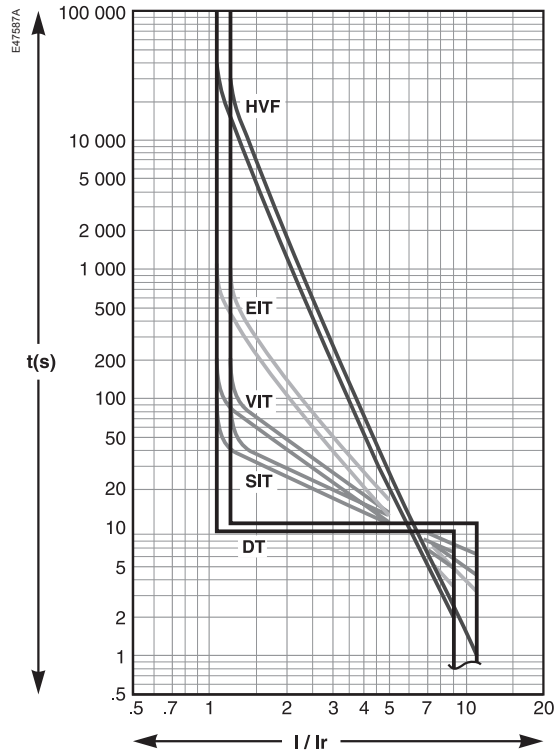

Tripping curves

Ground-fault protection - Micrologic 6.0 P

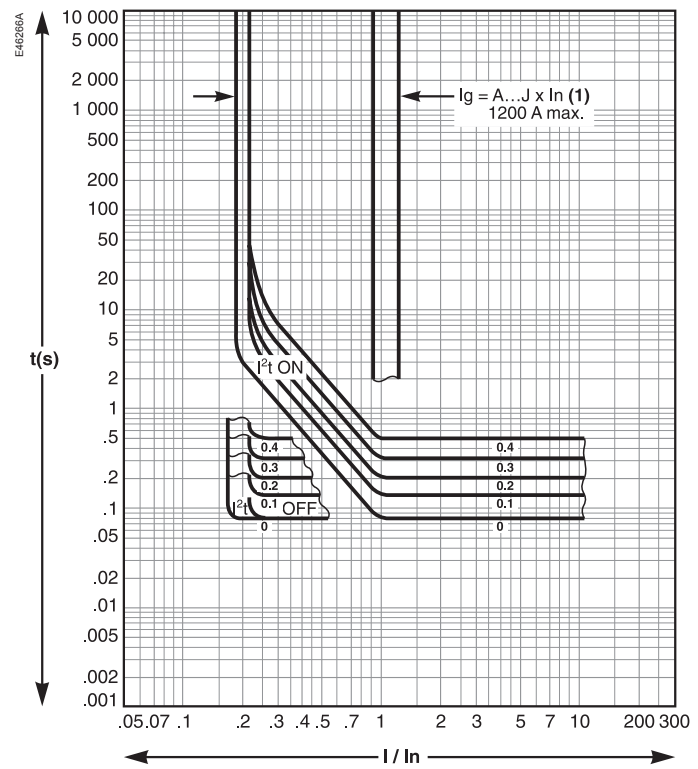

Micrologic P is equipped with a three-phase voltage power supply that, with respect to the distribution system, may be considered a delta load. The three-phase power supply reinjects voltage on an open phase.

The voltage-protection functions react as indicated below.

Minimum-voltage protection

This function is based on the measurement of the phase-to-phase voltages.

In diagrams 1, 3 and 4 on the next page, a fuse has blown. The control unit reinjects voltage on the failed phase and measures a phase-to-phase voltage higher than the actual voltage.

The phase-to-neutral voltage should be zero, but the value measured is not zero.

In diagram 2, the phase-to-neutral voltage is effectively zero and the measurement indicates zero as well.

By limiting the pickup threshold of the minimum-voltage protection to the 80% - 100% range of the rated distribution-system voltage, the differences between the real voltages and the measured values are not significant and Micrologic will operate under all circumstances in the expected manner.

Voltage-unbalance protection

This function is based on the measurement of the phase-to-phase voltages.

In diagrams 1, 3 and 4 on the next page, a fuse has blown. The control unit reinjects voltage on the failed phase and measures a phase-to-phase voltage higher than the actual voltage.

The phase-to-neutral voltage should be zero, but the value measured is not zero.

In diagram 2, the phase-to-neutral voltage is effectively zero and the measurement indicates zero as well.

By limiting the pickup threshold of the voltage-unbalance protection to the 0% - 20% range, the differences between the real voltages and the measured values are not significant and Micrologic will operate under all circumstances in the expected manner.

Phase failure

Detection of phase failure is not possible on the basis of the minimum-voltage and voltage-unbalance protection functions.

The Micrologic power supply requires at least two phases (between 100 and 690 V).

In diagrams 1, 3 and 4, if two phases have failed, Micrologic H measures for the three phases the value of the single voltage present (e.g. $U_{12} = U_{23} = U_{31} = 410 \text{ V}$).

Voltage measurements

■ Diagram 1

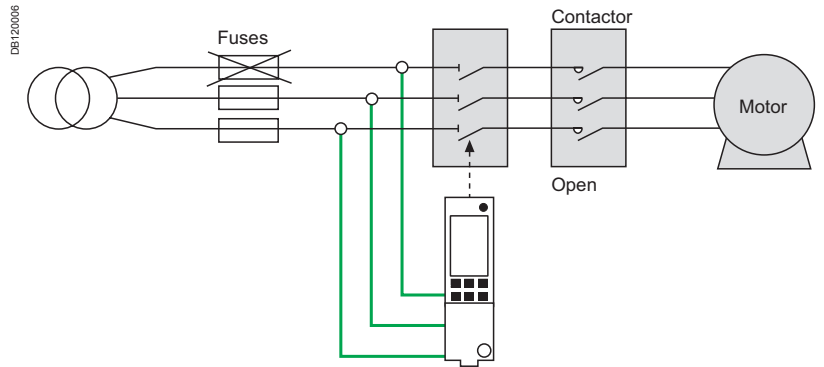

■ Diagram 2

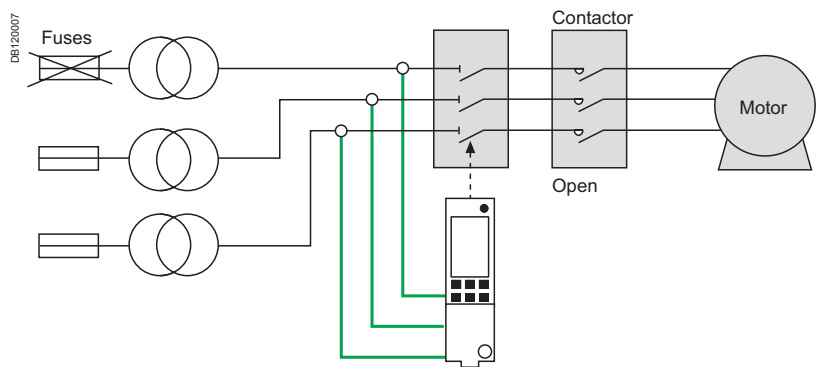

■ Diagram 3

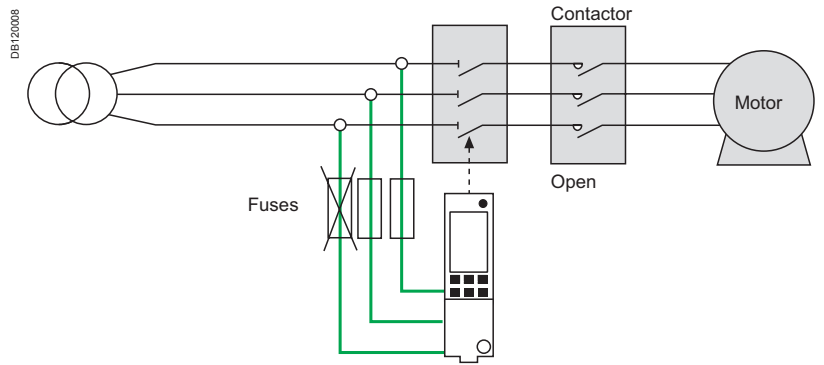

■ Diagram 4

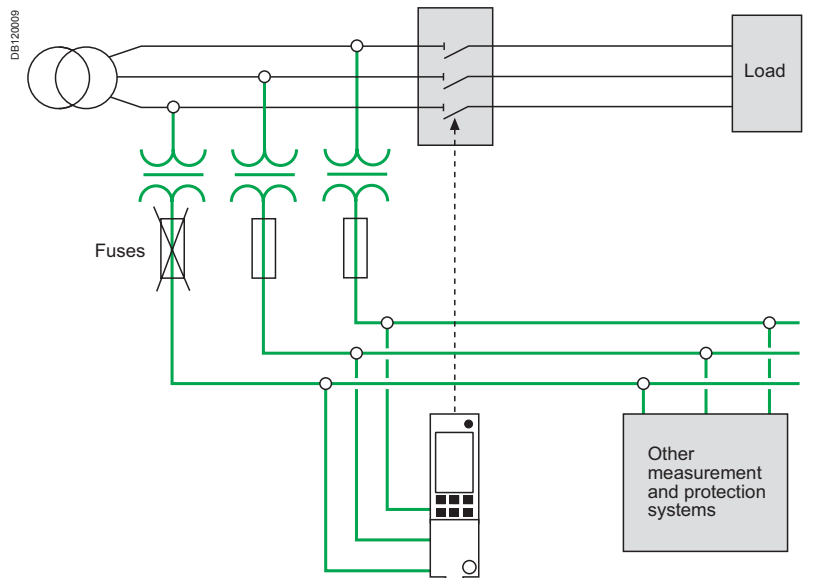

Zone selective interlocking (ZSI)

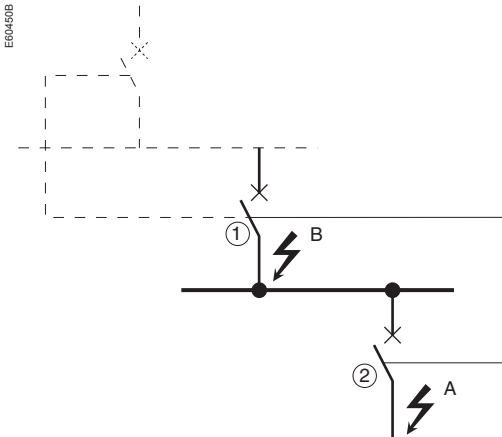

Operating principle

- A fault occurs at point A
Downstream device no. 2 clears the fault and sends a signal to upstream device no. 1, which maintains the short-time tripping delay t_{sd} or the ground-fault tripping delay t_g to which it is set.
- A fault occurs at point B
Upstream device no. 1 detects the fault. In the absence of a signal from a downstream device, the set time delay is not taken into account and the device trips according to the zero setting. If it is connected to a device further upstream, it sends a signal to that device, which delays tripping according to its t_{sd} or t_g setting.

Note:

On device no. 1, the t_{sd} and t_g tripping delays must not be set to zero because this would make discrimination impossible.

Connections between control units

A logic signal (0 or 5 volts) can be used for zone selective interlocking between the upstream and downstream circuit breakers.

- Micrologic 5.0 A, 6.0 A, 7.0 A
- Micrologic 5.0 E, 6.0 E
- Micrologic 5.0 P, 6.0 P, 7.0 P
- Micrologic 5.0 H, 6.0 H, 7.0 H.

An interface is available for connection to previous generations of trip units.

Important

If the protection function is not used on circuit breakers equipped for ZSI protection, a jumper must be installed to short terminals Z3, Z4 and Z5. If the jumper is not installed, the short-time and ground-fault tripping delays are set to zero, whatever the position of the adjustment dial.

Terminals Z1 to Z5 correspond to the identical indications on the circuit-breaker terminal blocks.

Wiring

- Maximum impedance: $2.7 \Omega / 300$ metres
- Capacity of connectors: 0.4 to 2.5 mm²
- Wires: single or multicore
- Maximum length: 3000 metres
- Limits to device interconnection:
 - the common ZSI - OUT (Z1) and the output ZSI - OUT (Z2) can be connected to a maximum of ten inputs
 - a maximum of 100 devices may be connected to the common ZSI - IN (Z3) and to an input ZSI - IN CR (Z4) or GF (Z5).

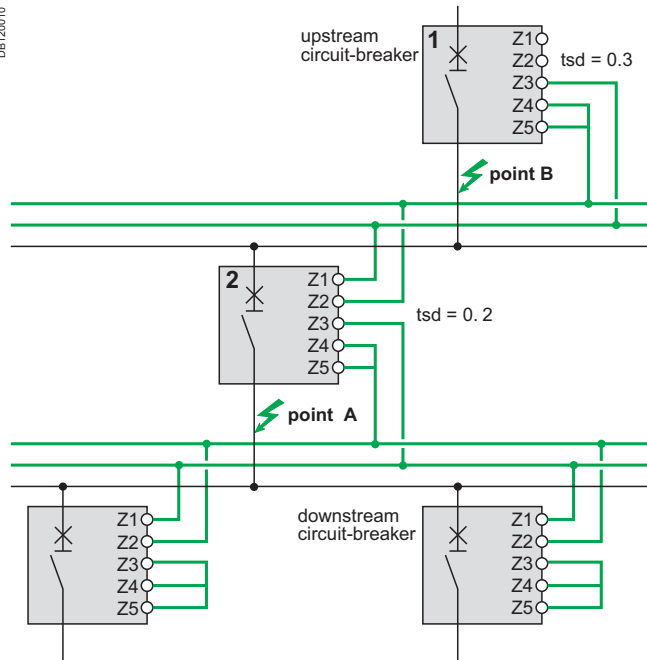

Test

The portable test kit may be used to check the wiring and operation of the zone selective interlocking between a number of circuit breakers.

Important

It is advised to use the AD power-supply module rather than an off-the-shelf 24 V power supply to ensure Class II insulation on the front panel of the Micrologic P control unit.

The power supply must have the following characteristics:

- output voltage 24 V DC
- DC ripple less than 5%
- power rating 5 W / 5 VA
- Dielectric withstand (input/output): 3 kV rms

AD power-supply module

The AD power-supply module provides auxiliary 24 V DC power for the control-unit functions listed below:

- Graphic display:
 - device OFF or not supplied
 - the long-time, short-time, instantaneous and ground-fault protection functions operate under all circumstances on their own power
- Activation of an M2C programmable contact

The AD power-supply module is required to assign an M2C programmable contact to an alarm.

The AD power-supply module can supply the following voltages:

- 110 V AC
- 220 V AC
- 380 V AC
- 24 / 30 V DC
- 48 / 60 V DC
- 125 V DC.

Battery module

Use of a BAT battery module, mounted in series with the AD power-supply module, ensures a continuous supply of 24 V DC power for 12 hours if the AD module fails.

Wiring diagrams

- Reliable or backed-up auxiliary system

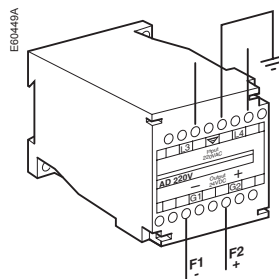

- Auxiliary system without back-up

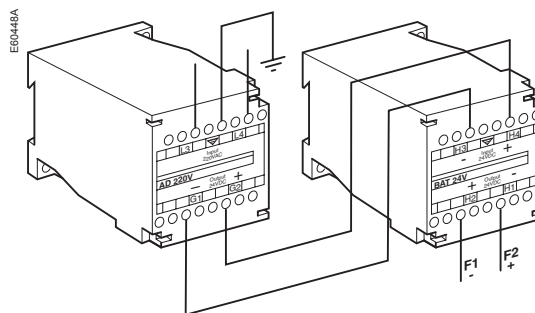

- Supply with the MC6 module

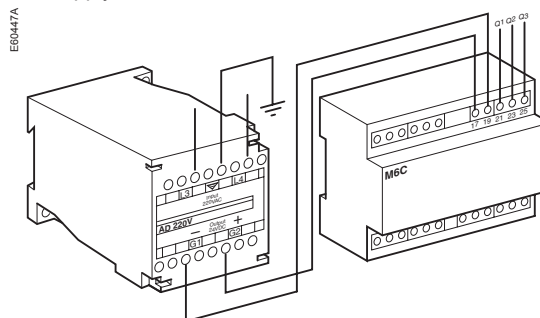

Using the AD power-supply module

The 24 V DC external power-supply (AD module) is required for certain operating configurations as indicated in the table below:

- yes means the power supply is required
- no means it is not required.

Circuit breaker	Closed	Open	Open
AC power present for Micrologic P	yes	yes	no
M2C, M6C programmable-contacts option	yes	yes	yes
Display function	no	no	yes
Time-stamping function	no	no	no
Circuit-breaker status indications and control via communications bus	no	no	no
Identification, settings, operation and maintenance aids via communications bus	no	no	yes

- If the 24 V DC external power supply (AD module) is used, the maximum cable length between 24 V DC (G1, G2) and the control unit (F1-, F2+) must not exceed 10 metres.
- The communications bus requires its own 24 V DC power source (E1, E2). This source is not the same as the 24 V DC external power-supply module (F1-, F2+).

Selection of the voltage-measurement inputs

The voltage-measurement inputs are standard equipment on the downstream connectors of the circuit breaker.

It is possible to measure distribution-system voltage externally using the PTE external voltage-measurement input option.

With this option, the internal voltage-measurement inputs are disconnected. The PTE option is required for voltages greater than 690 V (in which case a voltage transformer is required).

When the PTE option is implemented, the supply circuit of the voltage-measurement input must be protected against short-circuits. Installed as close as possible to the busbars, this protection function is ensured by a P25M circuit breaker (1 A rating) with an auxiliary contact (cat. no. 21104 and 21117).

The supply circuit of the voltage-measurement input is reserved exclusively for the control unit and must never be used to supply other circuits.

Changing the long-time rating plug

Select the long-time rating plug

A number of long-time rating plugs are available for Micrologic P control units.

Part number	Setting range for the I_r value	
33542	standard	0.4 to 1 x I_r
33543	low setting	0.4 to 0.8 x I_r
33544	high setting	0.8 to 1 x I_r
33545	without long-time protection	
	<ul style="list-style-type: none"> ■ $I_r = I_n$ for the short-time protection setting ■ Frequency protection not available ■ Load shedding / reconnection based on current not available 	

Important

Following any modifications to the long-time rating plug, all control-unit protection parameters must be checked.

Change the long-time rating plug

Proceed in the following manner.

1. open the circuit breaker
2. open the protective cover of the control unit
3. completely remove the long-time rating plug screw

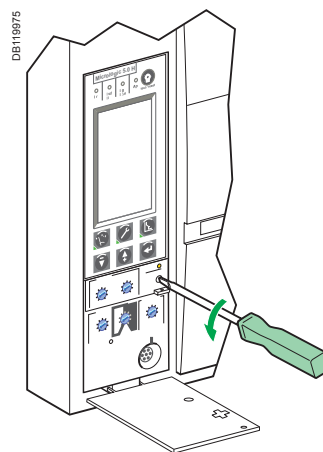
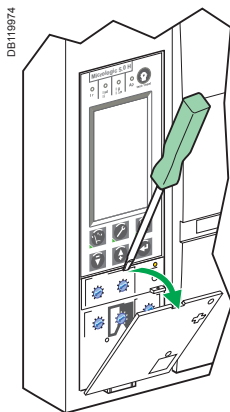

4. snap out the rating plug

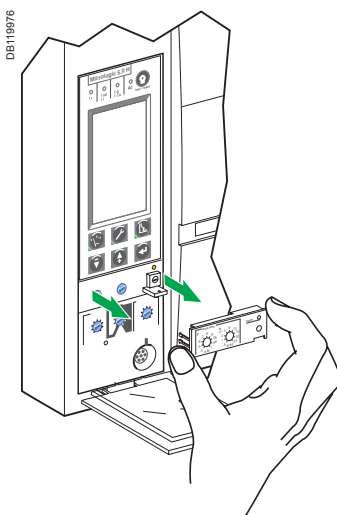

5. clip in the new rating plug

6. refit the screw for the long-time rating plug

7. check and/or modify the control-unit settings

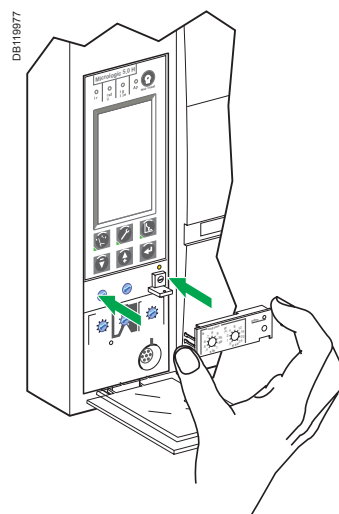

Important

If no long-time rating plug is installed, the control unit continues to operate under the following downgraded conditions:

- the long-time current setting I_r is 0.4
- the long-time tripping delay t_r corresponds to the value indicated by the adjustment dial
- the earth-leakage protection function is disabled
- the voltage-measurement inputs are disconnected.

Thermal memory

The thermal memory is the means to take into account temperature rise and cooling caused by changes in the flow of current in the conductors.

These changes may be caused by:

- repetitive motor starting
- loads fluctuating near the long-time protection settings
- repeated circuit-breaker closing on a fault.

Control units with a thermal memory record the temperature rise caused by each overload, even very short ones. This information stored in the thermal memory reduces the tripping time.

Micrologic control units and thermal memory

All Micrologic control units are equipped as standard with a thermal memory.

- For all protection functions, prior to tripping, the temperature-rise and cooling time constants are equal and depend on the t_r tripping delay:
 - if the tripping delay is short, the time constant is low
 - if the tripping delay is long, the time constant is high.
- For long-time protection, following tripping, the cooling curve is simulated by the control unit. Closing of the circuit breaker prior to the end of the time constant (approximately 15 minutes) reduces the tripping time indicated in the tripping curves.

Short-time protection and intermittent faults

For the short-time protection function, intermittent currents that do not provoke tripping are stored in the Micrologic P memory.

This information is equivalent to the long-time thermal memory and reduces the tripping delay for the short-time protection.

Following a trip, the short-time t_{sd} tripping delay is reduced to the value of the minimum setting for 20 seconds.

Ground-fault protection and intermittent faults

The ground-fault protection implements the same function as the short-time protection (see above).

The COM communications option can be used to remotely access the Micrologic P measurement, setting, maintenance and protection values.

Measurements

- Currents:
 - instantaneous currents
 - maximum and minimum instantaneous currents
 - average instantaneous currents
 - instantaneous-current unbalance per phase
 - maximum and minimum instantaneous-current unbalance per phase
- Demand current:
 - demand current per phase
 - maximum and minimum demand current per phase since last reset
 - prediction of demand current per phase
 - time-stamping of demand-current maximums and minimums
- Voltages:
 - phase-to-neutral and phase-to-phase voltages
 - average phase-to-neutral and phase-to-phase voltages
 - phase-to-neutral and phase-to-phase voltage unbalance
 - maximum and minimum phase-to-neutral and phase-to-phase voltage unbalance
- Active, reactive and apparent power per phase
- Demand power:
 - demand power per phase
 - maximum and minimum demand power per phase since last reset
 - maximum and minimum recommended demand power per phase
 - time-stamping of demand-power maximums and minimums
- Energy:
 - total active and reactive energy
 - positively incremented energy
 - negatively incremented energy
- System frequency
- Power factor
- Reset date of demand currents, demand power and energy.

Setup / Maintenance

- Setting of the control-unit date and time
- Password for the measurement module
- Control-unit ID code
- Control-unit ID name
- Selection of the measurement calculation algorithm
- Sign convention for the active power
- Total-energy measurement mode
- Interval for the demand-current calculation window
- Power quality indication
- Demand-power calculation mode
- Interval for the demand-power calculation window
- Battery-charge indication
- Trip and alarm histories
- Operation counter and contact-wear indicator
- Assignment and setup of programmable contacts
- Event log and maintenance register.

Protection

- Circuit-breaker rated current
- Type of neutral protection
- Long-time I^2t protection settings
- Long-time Idmtl protection settings
- Short-time protection settings
- Instantaneous-protection settings
- Ground-fault protection settings
- Earth-leakage protection settings
- Current-unbalance, I_{\neq} alarm and maximum-current protection settings
- Voltage-protection settings
- Setting for other protection functions.

Threshold and time-delay settings

Long-time I²t and Idmtl protection

Type	Range	Factory setting	Step	Accuracy
I _r current setting	0.4 to I _n	maximum	1 A	1.05 to 1.20 I _r
t _r tripping delay	0.5 to 24 s	maximum	0.5 s	- 20 %, + 0 %

Short-time protection

Type	Range	Factory setting	Step	Accuracy
I _{sd} pickup	1.5 to 10 I _r	maximum	10 A	± 10 %
t _{sd} tripping delay	0 - 0.1 - 0.2 - 0.3 - 0.4 s	maximum	0.1 s	

Instantaneous protection

Type	Range	Factory setting	Step	Accuracy
I _i pickup	2 to 15 I _n or OFF in Normal mode 2 to 15 I _n in ERMS mode	maximum	10 A	± 10 %

Ground-fault protection on Micrologic 6.0 P

Type	Range	Factory setting	Step	Accuracy
I _g pickup	depends on rating	maximum	1 A	± 10 %
t _g tripping delay	0 - 0.1 - 0.2 - 0.3 - 0.4 s	maximum	0.1 s	

Earth-leakage protection on Micrologic 7.0 P

Type	Range	Factory setting	Step	Accuracy
I _{Δn} pickup		maximum	0.1 A	- 20 %, + 0 %
Δt tripping delay	60 - 140 - 230 - 350 - 800 ms	maximum	1 setting	

Neutral protection

Type	Range	Factory setting
Three-pole device	Off, N/2, N, 1.6xN	off
Four-pole device	Off, N/2, N	N/2

Threshold and time-delay settings

Current protection

Type	Range	Factory setting	Step	Accuracy
Current unbalance I unbal				
Pickup threshold	5 % to 60 %	60 %	1 %	-10 %, +0 %
Dropout threshold	5 % of pickup threshold	pickup threshold	1 %	-10 %, +0 %
Pickup time delay	1 s to 40 s	40 s	1 s	-20 %, +0 %
Dropout time delay	10 s to 360 s	10 s	1 s	-20 %, +0 %
Ground-fault I \perp alarm				
Pickup threshold	20 A to 1200 A	120 A	1 A	+/- 15 %
Dropout threshold	20 A to pickup threshold	pickup threshold	1 A	+/- 15 %
Pickup time delay	1 s to 10 s	10 s	0.1 s	-20 %, +0 %
Dropout time delay	1 s to 10 s	1 s	0.1 s	-20 %, +0 %
Earth-leakage I \perp alarm				
Pickup threshold	0.5 A to 30 A	30 A	0.1 A	-20 %, +0 %
Dropout threshold	0.5 A to pickup threshold	pickup threshold	0.1 A	-20 %, +0 %
Pickup time delay	1 s to 10 s	10 s	0.1 s	-20 %, +0 %
Dropout time delay	1 s to 10 s	1 s	0.1 s	-20 %, +0 %
Maximum current I₁ max, I₂ max, I₃ max, I_N max				
Pickup threshold	0.2 I _n to I _n	I _n	1 A	± 6.6%
Dropout threshold	0.2 I _n to pickup threshold	pickup threshold	1 A	± 6.6%
Pickup time delay	15 s to 1500 s	1500 s	1 s	-20 %, +0 %
Dropout time delay	15 s to 3000 s	15 s	1 s	-20 %, +0 %

Voltage protection

Type	Range	Factory setting	Step	Accuracy
Minimum voltage U min				
Pickup threshold	100 V to U max pickup threshold	100 V	5 V	-5 %, +0 %
Dropout threshold	pickup threshold to U max pickup threshold	pickup threshold	5 V	-5 %, +0 %
Pickup time delay	1.2 s to 5 s	5 s	0.1 s	-0 %, +20 %
Dropout time delay	1.2 s to 36 s	1.2 s	0.1 s	-0 %, +20 %
Maximum voltage U max				
Pickup threshold	U min pickup threshold to 1200 V	725 V	5 V	-0 %, +5 %
Dropout threshold	100 V to pickup threshold	pickup threshold	5 V	-0 %, +5 %
Pickup time delay	1.2 s to 5 s	5 s	0.1 s	-0 %, +20 %
Dropout time delay	1.2 s to 36 s	1.2 s	0.1 s	-0 %, +20 %
Voltage unbalance U unbal				
Pickup threshold	2 % to 30 %	30 %	1 %	-20 %, +0 %
Dropout threshold	2 % to pickup threshold	pickup threshold	1 %	-20 %, +0 %
Pickup time delay	1 s to 40 s	40 s	1 s	-20 %, +0 %
Dropout time delay	10 s to 360 s	10 s	1 s	-20 %, +0 %

Threshold and time-delay settings

Other protection

Type	Range	Factory setting	Step	Accuracy
Reverse power rP max				
Pickup threshold	5 to 500 kW	500 kW	5 kW	± 2.5%
Dropout threshold	5 kW to pickup threshold	pickup threshold	5 kW	± 2.5%
Pickup time delay	0.2 s to 20 s	20 s	0.1 s	-0 %, +20 % ⁽¹⁾
Dropout time delay	1 s to 360 s	1 s	0.1 s	-0 %, +20 %
Maximum frequency F max				
Pickup threshold	F min pickup threshold to 440 Hz	65 Hz	0.5 Hz	± 0.5 Hz
Dropout threshold	45 Hz to pickup threshold	pickup threshold	0.5 Hz	± 0.5 Hz
Pickup time delay	1.2 s to 5 s	5 s	0.1 s	-0 %, +20 % ⁽²⁾
Dropout time delay	1.2 s to 36 s	1.2 s	0.1 s	-0 %, +20 % ⁽²⁾
Minimum frequency F min				
Pickup threshold	45 Hz to F max pickup threshold	45 Hz	0.5 Hz	± 0.5 Hz
Dropout threshold	pickup threshold to F max pickup threshold	pickup threshold	0.5 Hz	± 0.5 Hz
Pickup time delay	1.2 s to 5 s	5 s	0.1 s	-0 %, +20 % ⁽²⁾
Dropout time delay	1.2 s to 36 s	1.2 s	0.1 s	-0 %, +20 % ⁽²⁾
Phase rotation				
Pickup threshold	Ph1, Ph2, Ph3 or Ph1, Ph3, Ph2	Ph1, Ph2, Ph3	none	none
Dropout threshold	pickup threshold	pickup threshold	none	none
Pickup time delay	0.3 s	0.3 s	none	-0 %, +50 %
Dropout time delay	0.3 s	0.3 s	none	-0 %, +50 %

(1) + 30 % on dial 0.2 s

(2) + 30 % up to 1.5 s

Load shedding and reconnection

Type	Range	Factory setting	Step	Accuracy
Current I				
Pickup threshold	50 % to 100 % I _r	100 % I _r	1 %	± 6 %
Dropout threshold	30 % I _r to shedding threshold	shedding threshold	1 %	± 6 %
Pickup time delay	20 % to 80 % I _r	80 % I _r	1 %	-20 %, +0 %
Dropout time delay	10 s to 600 s	10 s	1 s	-20 %, +0 %
Power P				
Pickup threshold	200 kW to 10 000 kW	10 000 kW	50 kW	± 2.5 %
Dropout threshold	100 kW to shedding threshold	shedding threshold	50 kW	± 2.5 %
Pickup time delay	10 s to 3600 s	3600 s	10 s	-20 %, +0 %
Dropout time delay	10 s to 3600 s	10 s	10 s	-20 %, +0 %

M2C / M6C contacts

Type	Range	Factory setting	Step
Time-delay latching time delay	1 - 360 s	360 s	1 s

Micrologic setup

Type	Range	Factory setting	Step
Language	German English US English UK Italian French Spanish Chinese	English UK	
Date / time			1 s
Circuit-breaker selection		"no def"	
Neutral TC		no TC	
VT ratio			
primary voltage	min. 100 V, max. 1150 V	690 V	1 V
secondary voltage	min. 100 V, max. 690 V	690 V	1 V
System frequency	50/60 Hz or 400 Hz	50/60 Hz	

Measurement setup

Type	Range	Factory setting	Step
System type	3 Φ , 3 w, 3 CT 3 Φ , 4 w, 3 CT 3 Φ , 4 w, 4 CT	3 Φ , 4 w, 4 CT	
Demand-current calculation method	thermal or block interval	block interval	
type of window	fixed or sliding	sliding	
calculation interval	5 to 60 minutes	15 minutes	1 minute
Demand-power calculation method	thermal or block interval or sync. to comms	block interval	
type of window	fixed or sliding	sliding	
calculation interval	5 to 60 minutes	15 minutes	1 minute
Power sign	P+ P-	P+ (flow from top to bottom)	
Sign convention	IEEE IEEE alternate IEC	IEEE	

Communication setup

Type	Range	Factory setting
Com parameter	Modbus	
adress	1-47	47
baud rate	9600 to 19200 bauds	19200 bauds
parity	even none	even
Connection	2Wires+ULP or 4Wires	2Wires+ULP
Remote settings		
access authorisation	yes / no	yes
access code	0000 to 9999	0000
Remote control	manual automatic	automatic

Protection setup

Type	Range	Factory setting
Current protection voltage protection other protection	alarm / trip / OFF	OFF

Measurement setting ranges and accuracy

■ The accuracy of the current measurements depends on both the value displayed (or transmitted) and the circuit-breaker rating, where:
Accuracy = 0.5 % I_n + 1.5 % reading

Example:
For a circuit breaker with a 4000 A rating and a current displayed on Micrologic of 49 A, the accuracy is:
0.5 % x 4000 + 1.5 % x 49 = ±21 A

Measurement setting ranges and accuracy

Type	Range	Accuracy at 25 °C
Instantaneous current		
I1, I2, I3	0.05 x I _n to 20 x I _n	±1.5 %
I _N	0.05 x I _n to 20 x I _n	±1.5 %
I ⊥ ground	0.05 x I _n to I _n	±10 %
I ⊥ earth leakage	0 to 30 A	±1.5 %
I1 max, I2 max, I3 max	0.05 x I _n to 20 x I _n	±1.5 %
I _N max	0.05 x I _n to 20 x I _n	±1.5 %
I ⊥ max ground	0.05 x I _n to I _n	±10 %
I ⊥ max earth leakage	0 to 30 A	±1.5 %
Demand current		
I1, I2, I3	0.05 x I _n to 20 x I _n	±1.5 %
I _N	0.05 x I _n to 20 x I _n	±1.5 %
I1 max, I2 max, I3 max	0.05 x I _n to 20 x I _n	±1.5 %
I _N max	0.05 x I _n to 20 x I _n	±1.5 %
Phase-to-phase voltages		
U12	170 to 1150 V	±0.5 %
U23	170 to 1150 V	±0.5 %
U31	170 to 1150 V	±0.5 %
Phase-to-neutral voltages		
V1N	100 to 1150 V	±0.5 %
V2N	100 to 1150 V	±0.5 %
V3N	100 to 1150 V	±0.5 %
Average voltage		
U avg	170 to 1150 V	±0.5 %
Voltage unbalance		
U unbal	0 to 100 %	±0.5 %
Instantaneous power		
P	0.015 to 184 MW	±2 %
Q	0.015 to 184 Mvar	±2 %
S	0.015 to 184 MVA	±2 %
Power factor		
PF	-1 to +1	±2 %
Demand power		
P	0.015 to 184 MW	±2 %
Q	0.015 to 184 Mvar	±2 %
S	0.015 to 184 MVA	±2 %
P max	0.015 to 184 MW	±2 %
Q max	0.015 to 184 Mvar	±2 %
S max	0.015 to 184 MVA	±2 %
Total energy		
E.P	-10 ¹⁰ GWh to +10 ¹⁰ GWh	±2 %
E.Q	-10 ¹⁰ Gvarh to +10 ¹⁰ Gvarh	±2 %
E.S	-10 ¹⁰ GVAh to +10 ¹⁰ GVAh	±2 %
Total energy in		
E.P	-10 ¹⁰ GWh to +10 ¹⁰ GWh	±2 %
E.Q	-10 ¹⁰ Gvarh to +10 ¹⁰ Gvarh	±2 %
Total energy out		
E.P	-10 ¹⁰ GWh to +10 ¹⁰ GWh	±2 %
E.Q	-10 ¹⁰ Gvarh to +10 ¹⁰ Gvarh	±2 %
Frequency		
F	45 Hz to 440 Hz	±0.1 %

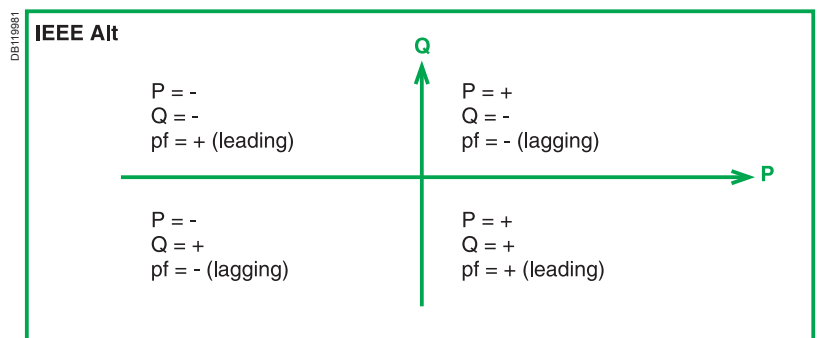
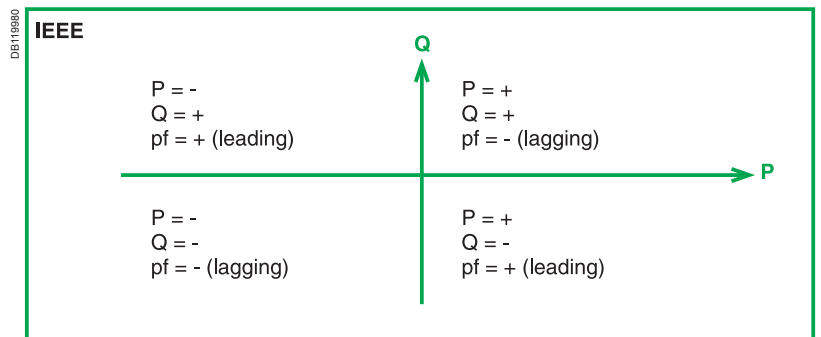
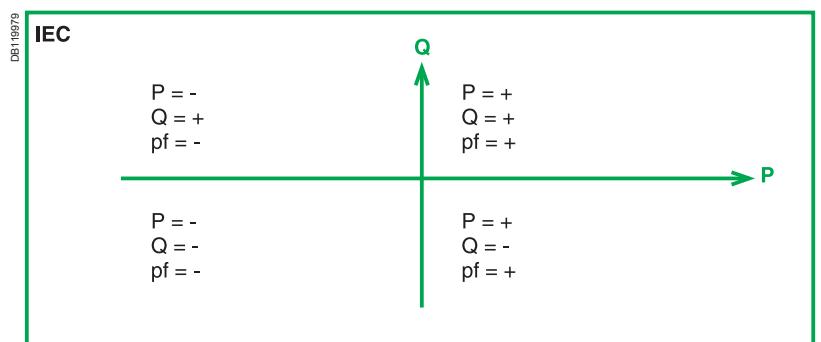
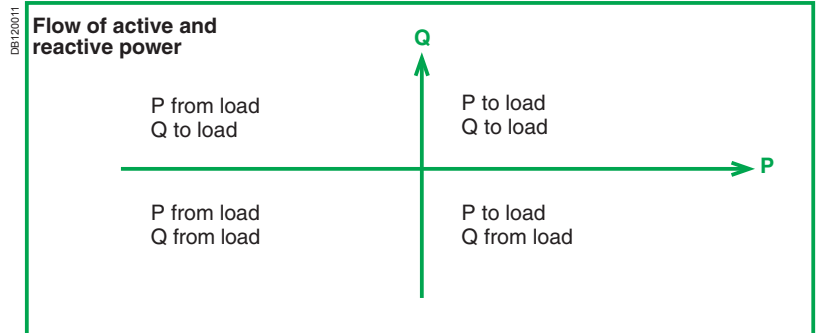

A	
Activation	26, 27, 28, 29, 32
Active, reactive, apparent energy	31, 65
Active, reactive, apparent power	31
AD power-supply module	79
Address	36
Alarm	32
Alarm history	33, 67
B	
Baud rate	48
Buttons	5, 6
C	
Circuit-breaker selection	43
COM option	36, 48, 83
Contact	38, 40
Contact wear	70
Control unit identification	4
Control-unit battery	5, 71
Current demand calculation	30, 45
D	
Date and time	42
Demand current	30, 59
Demand power	31, 63
Dropout	26, 27, 28, 29, 32
DT	21, 51
E	
Earth-leakage protection	25
Earth-leakage protection tripping delay Δt	25
EIT	21, 51
Energy reduction maintenance setting (ERMS)	23
F	
F max	32, 54
F min	32, 54
Fault	68
Frequency	31, 66
Full neutral protection	24, 53
Graphic display	5
Ground-fault / Earth-leakage fault protection test	72
Ground-fault protection	25
H	
Half neutral protection	24, 53
History, setup and maintenance menu	13, 16
HVF	21, 51
I	
I_{\perp}	52
I_{\perp} Alarm	26, 54
I avg	26
I max	26, 54
I unbal	26, 54
$I_{\Delta n}$ pickup	25
I^2t	20, 50
I _{dmtl}	21, 51
I _g pickup	25
I _i pickup	22
Infrared link	5
Instantaneous current	30, 58
Instantaneous protection	23
I _r current setting	20, 21
I _{sd} pickup	22

L	
Language	40
Latching	38
Lead seal for cover	5
LEDs	5, 34, 71
Load shedding / reconnection	29, 56
Long-time I ² t protection	20
Long-time Idmtl protection	21
Long-time plug	5, 81
M	
M2C / M6C	38, 40
Main screen	12, 58
Maximum demand current	30, 60
Maximum demand power	31, 64
Maximum instantaneous current	30, 58
Metering menu	13, 14
Modbus	48
N	
Negatively incremented energy	31, 65
Neutral CT	53
Neutral protection	11, 24
Neutral protection setting	11, 53
No neutral protection	24, 53
O	
Operation counter	70
Oversized neutral protection	24, 53
P	
Parity	48
Phase rotation	28, 54
Phase sequence	28
Phase-to-neutral and phase-to-phase voltage	30, 61
Portable test kit	72
Positively incremented energy	31, 65
Power demand calculation	31, 46
Power factor	63
Power sign	44
Power supply	79
Protection menu	13, 18
R	
Remote control	49
Remote settings	48
Resetting the alarms and fault indications	68
Resetting the contacts	38, 40
Resetting the energy values	65
Resetting the maximum demand current values	60
Resetting the maximum demand power values	64
Resetting the maximum instantaneous current values	59
Resetting the operation counter	70
rP max	28, 54
S	
Self-protection	35
Setting dials	5, 6
Short-time protection	22
Sign convention	89
SIT	21, 51
System frequency	44
System type	45

T	
Tab	7
Temperature	35
Test connector	5, 72
tg tripping delay	25
Thermal memory	20, 82
tr tripping delay	20, 21
Transformation ratio	44
Trip	4
Trip history	33, 69
Tripping curves	74
tsd tripping delay	22
U	
U max	27, 54
U min	27, 54
U unbal	27, 54, 61
V	
VIT	21, 51
Voltage U avg	27, 30, 61
Z	
Zone selective interlocking	78



Schneider Electric Industries SAS

35, rue Joseph Monier
CS 30323
F - 92506 Rueil Malmaison Cedex

As standards, specifications and designs change from time to time, please ask for confirmation of the information given in this publication.



This document has been printed on ecological paper

Design: Schneider Electric
Photos: Schneider Electric
Printed: