



# LBV311-XXACTTVMX

## LBV301

VIBRATING LEVEL SWITCH

**SICK**  
Sensor Intelligence.



Illustration may differ



### Ordering information

Type	Part no.
LBV311-XXACTVMX	6074937

Other models and accessories → [www.sick.com/LBV301](http://www.sick.com/LBV301)

### Detailed technical data

#### Features

<b>Medium</b>	Bulk solids
<b>Measurement</b>	Switch
<b>Probe length</b>	160 mm
<b>Process pressure</b>	-1 bar ... 16 bar
<b>Process temperature</b>	-50 °C ... +150 °C
<b>Fill material density</b>	≥ 0.02 g/cm <sup>3</sup>

#### Performance

<b>Accuracy of sensor element</b>	± 10 mm
<b>Reproducibility</b>	≤ 5 mm
<b>Response time</b>	500 ms when covered / 1,000 ms when uncovered
<b>MTBF</b>	4,17*10 <sup>6</sup> h

#### Electronics

<b>Residual ripple</b>	≤ 5 V <sub>pp</sub>
<b>Power consumption</b>	≤ 10 mA
<b>Initialization time</b>	< 2 s
<b>VDE protection class 2</b>	✓
<b>Connection type</b>	M20 x 1.5
<b>Output signal</b>	1 x PNP/NPN
<b>Supply voltage</b>	Volt-free transistor output PNP/ NPN: 10 V DC ... 55 V DC
<b>Hysteresis</b>	10 mm
<b>Output current</b>	< 300 mA
<b>Inductive load</b>	1 H
<b>Capacitive load</b>	100 nF
<b>Enclosure rating</b>	IP66 / IP67

#### Mechanics

<b>Process connection</b>	Tri-clamp 1 1/2" (316L, Ra < 0.8 μm)
---------------------------	--------------------------------------

<b>Housing material</b>	Stainless steel (investment casting) 316L
<b>Sensor material</b>	Stainless steel 316L, 318S

Ambient data

<b>Ambient operating temperature</b>	-40 °C ... +70 °C
<b>Ambient temperature, storage</b>	-40 °C ... +80 °C

Classifications

<b>ECLASS 5.0</b>	27273202
<b>ECLASS 5.1.4</b>	27273202
<b>ECLASS 6.0</b>	27273202
<b>ECLASS 6.2</b>	27273202
<b>ECLASS 7.0</b>	27273202
<b>ECLASS 8.0</b>	27273202
<b>ECLASS 8.1</b>	27273202
<b>ECLASS 9.0</b>	27273202
<b>ECLASS 10.0</b>	27273202
<b>ECLASS 11.0</b>	27273202
<b>ECLASS 12.0</b>	27273106
<b>ETIM 5.0</b>	EC002654
<b>ETIM 6.0</b>	EC002654
<b>ETIM 7.0</b>	EC002654
<b>ETIM 8.0</b>	EC002654
<b>UNSPSC 16.0901</b>	41111938

Type code

LBV311 type code

**Certification**

XX	without
CX	ATEX II 1G, ½ G, 2G Ex ia IIC T6
CK	ATEX II 1G, ½ G, 2G Ex ia IIC T6 + 1D, 1/2D, 2D Ex tD IP66 T
LX	ATEX II ½ G, 2G Ex d IIC T6
LK	ATEX II ½ G, 2G Ex d IIC T6 + 1D, ½ D, 2D Ex tD IP66 T
GX	ATEX II 1D, ½ D, 2D Ex tD IP66 T

**Execution / Process temperature**

A	Standard / -50 °C ... +150 °C
B	With spacer / -50 °C ... +250 °C
C	Detection of solids in water / -50 °C ... +150 °C

**Process connection / Material (see below)**

**Electronics**

C	Contact-free switch 20 ... 253 V AC (DC)
R	Relay (DPDT) 20 ... 72 V DC / 20 ... 253 V AC (3A)
T	Transistor (NPN/PNP) 10 ... 55 V DC
N	NAMUR signal

**Housing / Enclosure rating**

K	Plastic / IP 66, IP 67
A	Aluminum / IP 66, IP 67
V	Stainless steel (investment casting) 316L / IP 66, IP 67
8	Stainless steel (electropolished) 316L / IP 66, IP 67

**Cable entry / Male connector connection**

M	M20 x 1.5 / Without
---	---------------------

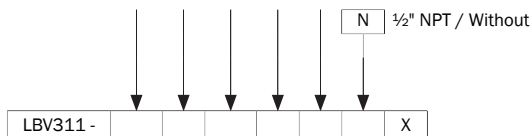

Not all variants of the type code can be combined! Not all available variants are shown.

### Process connection / Material

GC	Thread G 1, DIN 3852-A, PN 16 / 316L
GR	Thread G 1, DIN 3852-A, PN 16 / 316L, Ra < 0.8 µm
GG	Thread G 1 ½, DIN 3852-A, PN 16 / 316L
GP	Thread G 1 ½, DIN 3852-A, PN 16 / 316L, Ra < 0.8 µm
NC	Thread 1" NPT, ASME B1.20.1, PN 16 / 316L
NR	Thread 1" NPT, ASME B1.20.1, PN 16 / 316L, Ra < 0.8 µm
NH	Thread 1 ¼" NPT, ASME B1.20.1, PN 16 / 316L
NI	Thread 1 ¼" NPT, ASME B1.20.1, PN 16 / 316L, Ra < 0.8 µm
NG	Thread 1 ½" NPT, ASME B1.20.1, PN 16 / 316L
NP	Thread 1 ½" NPT, ASME B1.20.1, PN 16 / 316L, Ra < 0.8 µm
CT	Tri-Clamp 1 ½" / 316L, Ra < 0.8 µm
CV	Tri-Clamp 2" / 316L, Ra < 0.8 µm
CQ	Tri-Clamp 2 ½" / 316L, Ra < 0.8 µm
CM	Tri-Clamp 3 ½" / 316L, Ra < 0.8 µm
RP	Pipe connection DN 40, PN 40, DIN 11851 / 316L, Ra < 0.8 µm
RF	Pipe connection DN 40, PN 40, DIN 11864-1, form A / 316L, Ra < 0.8 µm
RH	Pipe connection DN 65, PN 25, DIN 11851 / 316L, Ra < 0.8 µm
TV	Tuohenhagen Varivent DN 32.1 ½", PN 25 / 316L, Ra < 0.8 µm
C2	Bundle clamp DN 40, PN 40, DIN 11864-3, form A / 316L, Ra < 0.8 µm
BF	Flange DN 32, PN 40, form C, DIN 2501 / 316L
DF	Flange DN 40, PN 40, form C, DIN 2501 / 316L
AU	Flange DN50 10K RF, JIS / 316L
HU	Flange DN65 10K RF, JIS / 316L

EF	Flange DN 50, PN 40, form C, DIN 2501 / 316L
4F	Flange DN 65, PN 16, form C, DIN 2501 / 316L
No error	Flange DN 80, PN 40, form C, DIN 2501 / 316L
ZF	Flange DN 100, PN 6, form C, DIN 2501 / 316L
MF	Flange DN 100, PN 16, form C, DIN 2501 / 316L
OF	Flange DN 100, PN 40, form C, DIN 2501 / 316L
3F	Flange DN 125, PN 6, form C, DIN 2501 / 316L
QF	Flange DN 150, PN 16, form C, DIN 2501 / 316L
2F	Flange DN 200, PN 10, form C, DIN 2501 / 316L
EB	Flange DN 50, PN 40, EN 1092-1, form B1 / 316L
DA	Flange 1 ½" 150 lb RF, ANSI B16.5 / 316L
EA	Flange 1 ½" 300 lb RF, ANSI B16.5 / 316L
HA	Flange 2" 150 lb RF, ANSI B16.5 / 316L
IA	Flange 2" 300 lb RF, ANSI B16.5 / 316L
OA	Flange 3" 150 lb RF, ANSI B16.5 / 316L
OE	Flange 3" 150 lb FF, ANSI B16.5 / 316L
PA	Flange 3" 300 lb RF, ANSI B16.5 / 316L
PE	Flange 3" 300 lb FF, ANSI B16.5 / 316L
JA	Flange 3 ½" 150 lb RF, ANSI B16.5 / 316L
SA	Flange 4" 150 lb RF, ANSI B16.5 / 316L
UA	Flange 4" 300 lb RF, ANSI B16.5 / 316L
BU	Flange DN80 10K RF, JIS / 316L
CU	Flange DN100 10K RF, JIS / 316L

### Dimensional drawing (Dimensions in mm (inch))

LBV311 threaded version G 1 ½ A

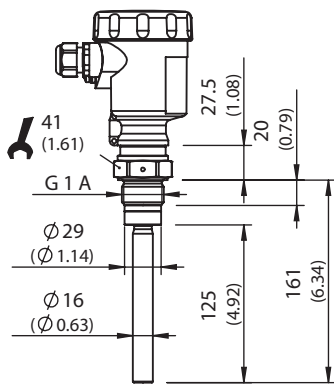

All dimensions in mm (inch)

LBV311 threaded version G 1 A

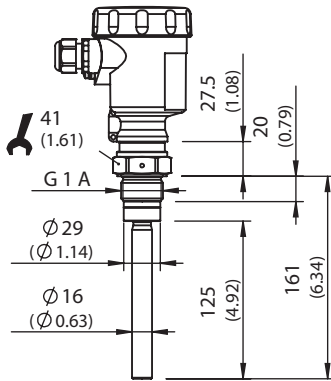

All dimensions in mm (inch)

LBV311 temperature adapter -50 °C ... +250 °C



All dimensions in mm (inch)

LBV311 threaded version Tri-Clamp



All dimensions in mm (inch)

### Connection diagram

PNP action

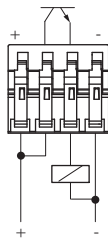

NPN action

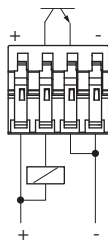

Transistor connection diagram

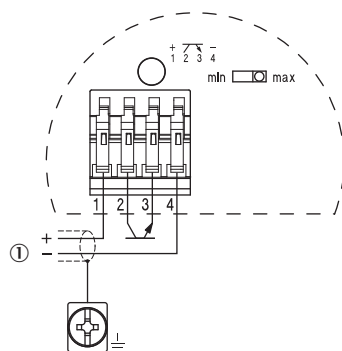

### Instruction for installation

Horizontal mounting



- ① Protective sheet
- ② Concave protective sheet for abrasive solids

### Characteristic curve

Ambient temperature - process temperature



- ① Process temperature in °C (°F)
- ② Ambient temperature in °C (°F)
- ③ Temperature range with temperature adapter

## SICK AT A GLANCE

SICK is one of the leading manufacturers of intelligent sensors and sensor solutions for industrial applications. A unique range of products and services creates the perfect basis for controlling processes securely and efficiently, protecting individuals from accidents and preventing damage to the environment.

We have extensive experience in a wide range of industries and understand their processes and requirements. With intelligent sensors, we can deliver exactly what our customers need. In application centers in Europe, Asia and North America, system solutions are tested and optimized in accordance with customer specifications. All this makes us a reliable supplier and development partner.

Comprehensive services complete our offering: SICK LifeTime Services provide support throughout the machine life cycle and ensure safety and productivity.

For us, that is “Sensor Intelligence.”

## WORLDWIDE PRESENCE:

Contacts and other locations –[www.sick.com](http://www.sick.com)