

# DFS60S-BD0A00S01

DFS60S Pro

**INCREMENTAL ENCODERS**

**SICK**  
Sensor Intelligence.

Illustration may differ

### Ordering information

Type	Part no.
DFS60S-BDOA00S01	1093703

Other models and accessories → [www.sick.com/DFS60S\\_Pro](http://www.sick.com/DFS60S_Pro)



### Detailed technical data

#### Features

<b>Special device</b>	✓
<b>Specialty</b>	Long statour coupling premounted
<b>Standard reference device</b>	DFS60S-BDOA01024, 1069535

#### Safety-related parameters

<b>Safety integrity level</b>	SIL 2 (IEC 61508), SILCL2 (IEC 62061) <sup>1)</sup>
<b>Performance level</b>	PL d (EN ISO 13849) <sup>1)</sup>
<b>Category</b>	3 (EN ISO 13849)
<b>PFH<sub>D</sub>: Probability of dangerous failure per hour</b>	1.7 x 10 <sup>-8</sup> <sup>2)</sup>
<b>T<sub>M</sub> (mission time)</b>	20 years (EN ISO 13849)
<b>Safety-related measuring step</b>	0.09°, Quadrature analysis
<b>Safety-related accuracy</b>	± 0.09°

<sup>1)</sup> For more detailed information on the exact configuration of your machine/unit, please consult your relevant SICK branch office.

<sup>2)</sup> The values displayed apply to a diagnostic degree of coverage of 99%, which must be achieved by the external drive system and 95 °C operating temperature.

#### Performance

<b>Sine/cosine periods per revolution</b>	1,024
<b>Measuring step</b>	0.3 ", For interpolation of the sine/cosine signals with e.g. 12 bit <sup>1)</sup>
<b>Integral non-linearity</b>	Typ. ± 45 " (without mechanical tension of the stator coupling)
<b>Differential non-linearity</b>	± 7 "

<sup>1)</sup> Not safety-related.

#### Interfaces

<b>Communication interface</b>	Incremental
<b>Communication Interface detail</b>	Sin/Cos <sup>1)</sup>
<b>Initialization time</b>	50 ms <sup>2)</sup>
<b>Output frequency</b>	≤ 153.6 kHz

<sup>1)</sup> 1.0 V<sub>SS</sub> (differential).

<sup>2)</sup> Valid signals can be read once this time has elapsed.

<b>Power consumption</b>	≤ 0.7 W (without load)
<b>Load resistance</b>	≥ 120 Ω

<sup>1)</sup> 1.0 V<sub>SS</sub> (differential).

<sup>2)</sup> Valid signals can be read once this time has elapsed.

## Electrical data

<b>Connection type</b>	Male connector, M23, 12-pin, radial
<b>Supply voltage</b>	4.5 ... 32 V
<b>Reference signal, number</b>	1
<b>Reference signal, position</b>	90°, electronically, gated with Sinus and Cosinus
<b>Reverse polarity protection</b>	✓
<b>Protection class</b>	III (according to DIN EN 61140)
<b>Short-circuit protection of the outputs</b>	✓ <sup>1)</sup>

<sup>1)</sup> Short-circuit to another channel or GND permitted for max. 30 s. In the case of U<sub>S</sub> ≤ 12 V additional short-circuit to U<sub>S</sub> permitted for max. 30 s.

## Mechanical data

<b>Mechanical design</b>	Blind hollow shaft
<b>Shaft diameter</b>	10 mm With feather key groove
<b>Weight</b>	Approx. 0.25 kg <sup>1)</sup>
<b>Shaft material</b>	Stainless steel
<b>Flange material</b>	Die-cast zinc
<b>Housing material</b>	Aluminum die cast
<b>Start up torque</b>	≤ 0.8 Ncm (+20 °C)
<b>Operating torque</b>	≤ 0.6 Ncm (+20 °C)
<b>Permissible movement static</b>	± 0.3 mm (radial) ± 0.5 mm
<b>Permissible movement dynamic</b>	± 0.05 mm (radial) ± 0.1 mm (axial)
<b>Operating speed</b>	≤ 6,000 min <sup>-1</sup> <sup>2)</sup>
<b>Moment of inertia of the rotor</b>	56 gcm <sup>2</sup>
<b>Bearing lifetime</b>	3.6 x 10 <sup>9</sup> revolutions <sup>3)</sup>
<b>Angular acceleration</b>	≤ 500,000 rad/s <sup>2</sup>

<sup>1)</sup> Based on encoder with male connector.

<sup>2)</sup> Allow for self-heating of approx. 3.0 K per 1,000 rpm regarding the permissible operating temperature.

<sup>3)</sup> On maximum operating speed and temperature.

## Ambient data

<b>EMC</b>	According to EN 61000-6-2, EN 61000-6-3 and IEC 61326-3-1
<b>Enclosure rating</b>	IP65 (IEC 60529) <sup>1)</sup>
<b>Permissible relative humidity</b>	90 % (Condensation not permitted)
<b>Operating temperature range</b>	-30 °C ... +95 °C <sup>2)</sup>

<sup>1)</sup> With male connector and mating connector fitted minimum IP65.

<sup>2)</sup> Allow for self-heating of approx. 3.0 K per 1,000 rpm regarding the permissible operating temperature.

<sup>3)</sup> Checked to operation with vector length monitoring.

<b>Storage temperature range</b>	-30 °C ... +85 °C, without package
<b>Resistance to shocks</b>	100 g, 6 ms (EN 60068-2-27) <sup>3)</sup>
<b>Resistance to vibration</b>	10 g, 10 Hz ... 1,000 Hz (EN 60068-2-6)

<sup>1)</sup> With male connector and mating connector fitted minimum IP65.

<sup>2)</sup> Allow for self-heating of approx. 3.0 K per 1,000 rpm regarding the permissible operating temperature.

<sup>3)</sup> Checked to operation with vector length monitoring.

### Classifications

<b>eCl@ss 5.0</b>	27270501
<b>eCl@ss 5.1.4</b>	27270501
<b>eCl@ss 6.0</b>	27270590
<b>eCl@ss 6.2</b>	27270590
<b>eCl@ss 7.0</b>	27270501
<b>eCl@ss 8.0</b>	27270501
<b>eCl@ss 8.1</b>	27270501
<b>eCl@ss 9.0</b>	27270501
<b>eCl@ss 10.0</b>	27270501
<b>eCl@ss 11.0</b>	27270501
<b>eCl@ss 12.0</b>	27270501
<b>ETIM 5.0</b>	EC001486
<b>ETIM 6.0</b>	EC001486
<b>ETIM 7.0</b>	EC001486
<b>ETIM 8.0</b>	EC001486
<b>UNSPSC 16.0901</b>	41112113

**Dimensional drawing** (Dimensions in mm (inch))

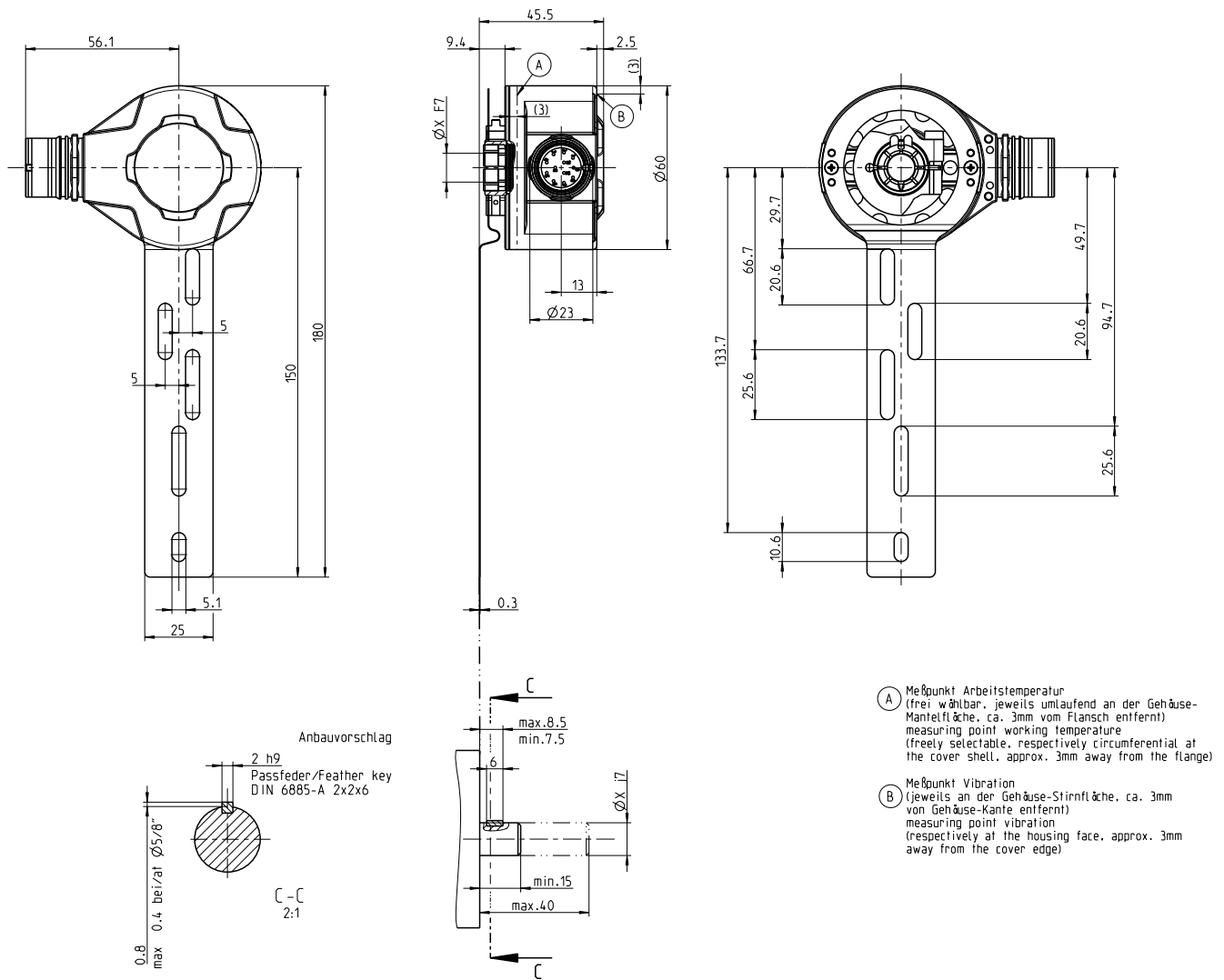

## SICK AT A GLANCE

SICK is one of the leading manufacturers of intelligent sensors and sensor solutions for industrial applications. A unique range of products and services creates the perfect basis for controlling processes securely and efficiently, protecting individuals from accidents and preventing damage to the environment.

We have extensive experience in a wide range of industries and understand their processes and requirements. With intelligent sensors, we can deliver exactly what our customers need. In application centers in Europe, Asia and North America, system solutions are tested and optimized in accordance with customer specifications. All this makes us a reliable supplier and development partner.

Comprehensive services complete our offering: SICK LifeTime Services provide support throughout the machine life cycle and ensure safety and productivity.

For us, that is “Sensor Intelligence.”

## WORLDWIDE PRESENCE:

Contacts and other locations –[www.sick.com](http://www.sick.com)