 **NOTE:** *In the interest of higher quality and value, Panduit products are continually being improved and updated. Consequently, pictures may vary from the enclosed product.*



www.panduit.com

Region

USA & Canada
Latin America
Europe/Middle East
Asia Pacific
Japan
Australia

Telephone

1-866-871-4571
1-708-532-1800
+31-546-580-452
65-6305-7575
81-3-6863-6060
613-9794-9020

e-mail

GA-TechSupport@panduit.com
TechSupportLatAm@panduit.com
TechSupportEMEA@panduit.com
TechSupportAP@panduit.com
TechSupportAP@panduit.com
TechSupportAP@panduit.com

The information contained in this manual is subject to change without notice and does not represent a commitment on the part of Panduit corporation. No part of this manual may be reproduced or transmitted in any form or by any means, for any purpose other than the purchaser's personal use, without the expressed written permission of Panduit Corporation.

Agency Compliance and Approvals



EN 55032: Class A

EN 55024

EN 55035

EN 60950-1

EN 62368

This is a class A product. In a domestic environment this product may cause radio interference in which case the user may be required to take adequate measures.

FCC part 15B, Class A

ICES-003, Class A

This equipment has been tested and found to comply with the limits for a Class A digital device, pursuant to Part 15 of the FCC Rules. These limits are designed to provide reasonable protection against harmful interference when the equipment is operated in a commercial environment.



Operation is subject to the following two conditions: (1) This device may cause harmful interference, and (2) this device must accept any interference received, including interference that may cause undesired operation.

This equipment generates, uses, and can radiate radio frequency energy and, if not installed and used in accordance with the manufacturer's instruction manual, may cause harmful interference with radio communications. Operation of this equipment in a residential area is likely to cause harmful interference, in which case you will be required to correct the interference at your own expense.

This Class A digital apparatus complies with Canadian ICES-003.

Cet appareil numérique de la classe A est conforme à la norme NMB-003 du Canada.



AS/NZS CISPR 32, Class A



UL 60950-1 (2nd Edition)
CSA C22.2 No. 60950-1-07 (2nd Edition)
UL 62368-1, 2nd Edition, 2014-12-01 (Audio/video, Information and
Communication Technology Equipment - Part 1: Safety Requirements) CAN/CSA
C22.2 No. 62368-1-14, 2nd Edition, 2014-12 (Audio/video, Information and
Communication Technology Equipment - Part 1: Safety Requirements)



Energy Star for Imaging Equipment Version 3.0







IS 13252(Part 1)/

IEC 60950-1

Specifications are subject to change without notice.

Safety Instructions

	<p>WARNING</p> <p>Read and understand all of the instructions and safety information in this manual before operating or servicing this tool.</p>
	<p>CAUTION</p> <ul style="list-style-type: none"> • Danger of explosion if battery is incorrectly replaced. • Replace only with the equivalent type recommended by the manufacture. • Dispose of used batteries according to the manufacturer's instructions.
	<p>CAUTION</p> <p>Electric Shock Hazard:</p> <ul style="list-style-type: none"> • Before you connect the equipment to the power outlet, please check the voltage of the power source. • Disconnect the equipment from the voltage of the power source to prevent possible transient over voltage damage. • Don't pour any liquid to the equipment to avoid electrical shock.
	<p>CAUTION</p> <ul style="list-style-type: none"> • Keep the equipment away from moisture and humidity.



CAUTION

- * ONLY qualified service personnel for safety reasons, should open equipment.
- * Don't repair or adjust energized equipment alone under any circumstances. Someone capable of providing first aid must always be present for your safety.
- * Always obtain first aid or medical attention immediately after an injury. Never neglect an injury, no matter how slight it seems.

Table of Contents

- 1. Introduction 6**
 - 1.1 Product Introduction..... 6
 - 1.2 Product Features 6
 - 1.3 General Specification 7
 - 1.4 Print Specifications 7
 - 1.5 Ribbon Specifications..... 7
 - 1.6 Media Specifications 8
- 2. Operations Overview 8**
 - 2.1 Unpacking and Inspection 8
 - 2.2 Printer Overview 9
 - 2.3 Operator Controls 11
 - 2.4 Setting up the Printer..... 12
 - 2.5 Loading Ribbon..... 13
 - 2.6 Loading the Media 17
 - 2.7 Adjustment Knob 19
- 3. Printer/Menu/Sensor Function 24**
 - 3.1 Printer Function Overview..... 25
 - 3.2 Setup Menu Overview 25
 - 3.3 Advanced Menu 26
 - 3.4 Sensor Overview 28
- 4. Diagnostics 29**
 - 4.1 Diagnosing Using Print Config 29
- 5. TroubleshootingError! Bookmark not defined.**
 - 5.1 Common Errors..... 31
- 6. Maintenance..... 34**
 - 6.1 Cleaning Tools & Methods of Maintenance 34

1. Introduction

1.1 Product Introduction

Thank you very much for purchasing a Panduit printer.

The TDP43HET and TDP46HET Thermal Transfer Desktop Printers produce high-quality printed labels for a wide range of labeling applications for OEM, MRO, construction, data centers, enterprise, and industrial automation. The rugged, high-speed printers are designed for dependable use in industrial, construction, and harsh environments. Using the included Easy-Mark™ Labeling Software, the printers provide simple setup and operation with all Panduit thermal transfer label media to create wire and cable markers, terminal block labels, equipment labels, marker plates, panel labels, network labels, and safety and facility labels. We recommend the use of Easy-Mark-Plus, version 1.4, or higher.

1.2 Product Features

The printer offers the following standard features.

Product standard feature	TDP43HET (300 dpi)	TDP46HET (600 dpi)
Thermal transfer printing	○	○
Direct thermal printing	○	○
High quality die-cast aluminum design	○	○
Metal cover with large clear media view window	○	○
Moveable gap sensor (position full web adjustable)	○	○
Moveable black mark sensor (position full web adjustable)	○	○
Ribbon end sensor	○	○
LCD touch screen display	○	○
Control panel with 6 operation buttons	○	○
Real time clock	○	○
Print Speed up to 12 ips (inches per second)	○	
Print Speed up to 6 ips (inches per second)		○

1.3 General Specification

General Specifications	
Physical dimensions	276 mm (W) x 326 mm (H) x 502 mm (D)
Weight	34 lb.
Electrical	Internal switching power supply Input: 100~240VAC, 50/60Hz Output: 24V, 8.33A, 200W
Environmental condition	Operation: 5 ~ 40°C (41 ~ 104°F), 25~85% non-condensing Storage: -40 ~ 60 °C (-40 ~ 140°F), 5~90% non-condensing

1.4 Print Specifications

Print Specifications	TDP43HET (300 dpi)	TDP46HET (600 dpi)
Print head resolution	300 dots/inch (12 dots/mm)	600 dots/inch (24 dots/mm)
Printing method	Thermal transfer and direct thermal	
Dot size (width x length)	0.084 x 0.084 mm (1 mm = 12 dots)	0.042 x 0.042 mm (1 mm = 24 dots)
Print speed (inches per second)	2-12 ips ips selectable up to 12 ips	1-6 ips ips selectable up to 6 ips
Max. print width	104 mm (4.09")	
Max. print length	1854.2 mm (73")	1016 mm (40")

1.5 Ribbon Specifications

Ribbon Specifications	
Ribbon outside diameter	90 mm max.
Ribbon length	600 meter max.
Ribbon core inside diameter	1 inch (25.4 mm)
Ribbon width	Max. 114.3 mm (4.5")
	Min. 25.4 mm (1.0")
Ribbon wound type	Ink coated inside wound
Ribbon end type	Transparency

1.6 Media Specifications

1.6.1 Industrial model

Media Specifications	TDP43HET (300 dpi)	TDP46HET (600 dpi)
Label roll capacity	203.2 mm (8")	
Media alignment	Edge alignment	
Media type	Continuous, die-cut, black mark, fan-fold, notch	
Media wound type	Printing face inside/outside wound	
Media width (label + liner)	Max. 118 mm (4.6")	
	Min. 25.4 mm (1.0")	
Media thickness (label + liner)	Max. 0.30 mm (11.8 mil)	
	Min. 0.06 mm (2.36 mil)	
Media core diameter	Max. 76.2 mm (3")	
	Min. 25.4 mm (1")	
Label length	Max. 1,854 mm (73")	Max. 1016 mm (40")
	Min. 5 mm (0.20")	Min. 5 mm (0.20")
Label length (peeler mode)	Max. 152.4 mm (6")	
	Min. 25.4 mm (1")	
Gap height	Min. 2 mm	
Black mark height	Min. 2 mm	
Black mark width	Min. 8 mm (0.31")	

2. Operations Overview

2.1 Unpacking and Inspection

This printer has been specially packaged to withstand damage during shipping. Please carefully inspect the packaging and printer upon receiving the printer. Please retain the packaging materials in case you need to reship the printer.

Unpacking the printer, the following items are included in the carton.

- One printer unit
- One Easy-Mark-Plus™ CD (Labeling Software)
- One quick installation guide

- Appropriate power cord(s)
- One USB interface cable
- One Windows driver disc, with user manuals
- One user manual (hard copy)
- One warranty card
- One Ink Ribbon (Hybrid)
- One Utility Knife (*CAUTION, SHARP!*)

If any parts are missing, please contact Panduit Customer Service.

2.2 Printer Overview

2.2.1 Exterior View

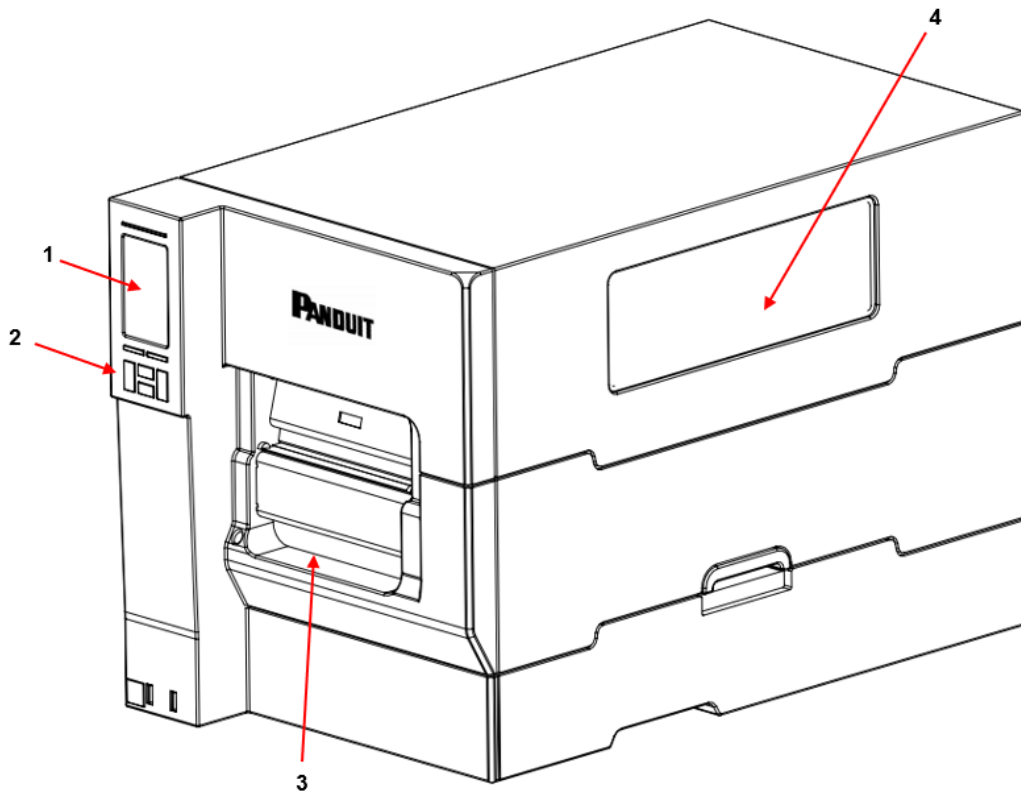

1. Touch Screen
2. Front Panel Buttons
3. Label Exit Chute
4. View Window

2.2.2 Interior view

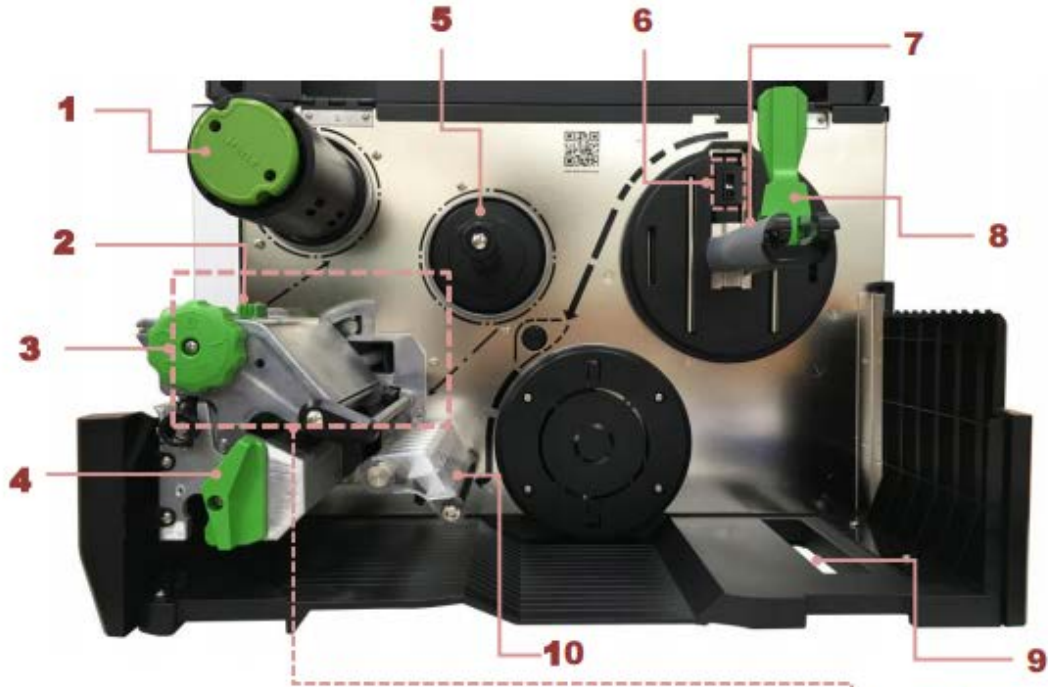

1. Ribbon rewind spindle
2. Print head pressure position adjustment knob
3. Print head pressure adjustment knob
4. Print head release lever
5. Ribbon supply spindle
6. Media near end sensor
7. Label supply spindle
8. Label roll guard
9. External label entrance chute
10. Damper
11. Print head
12. Platen roller
13. Ribbon sensor
14. Black mark sensor (shown as ↓)
15. Gap sensor (shown as ▽)
16. Front label guide

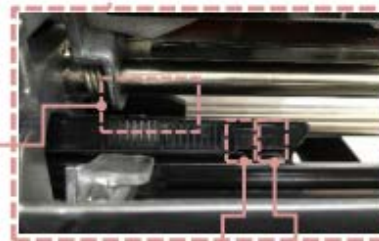
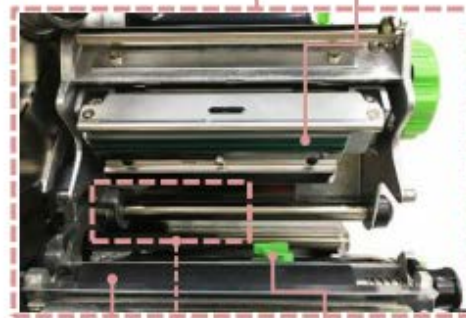



2.3 Operator Controls

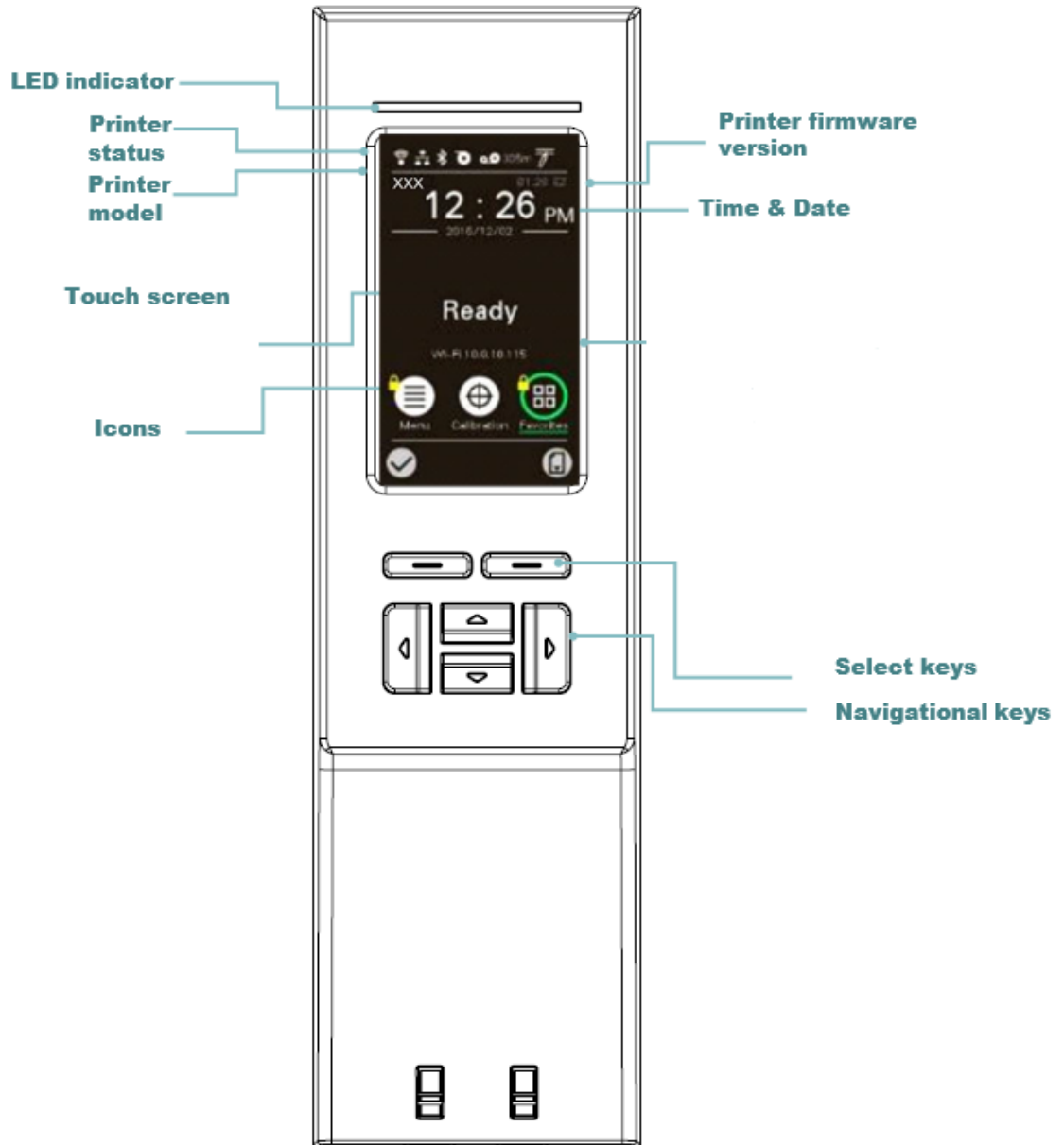

2.3.1 Front Panel Display



2.3.2 Indicators

LED	Status	Indication
 POWER	Off	The printer power is turned off
	On	The printer power is turned on
 ON-LINE	On	Printer is ready
	Blinking	Pause
		Downloading data into printer.
 ERROR	Off	Printer is ready
	On	“CARRIAGE OPEN” or “CUTTER ERROR”
	Blinking	“NO PAPER”, “PAPER JAM”, “NO RIBBON” or “CLEAN DATA”

2.3.3 Front Panel Keys

Keys	Function
	The Select Keys allow the user to select left or right options based on what is shown on the touch screen.
	The Navigational Keys allow the user to navigate between menu options shown on the touch screen.

2.4 Setting up the Printer

1. Place the printer on a flat, secure surface.
2. Make sure the power switch is off.
3. Connect the printer to the computer with the provided USB cable.
4. Plug the power cord into the AC power cord socket at the rear of the printer, and then plug the power cord into a properly grounded power outlet.

Note: Please switch printer power to OFF (O), before plugging the power cord into the power cord socket.

2.5 Loading Ribbon

2.5.1 Loading Ribbon



1. Open the printer right side cover.



2. Install the ribbon onto ribbon supply spindle.





3. Push the Print head release lever to open print head mechanism.

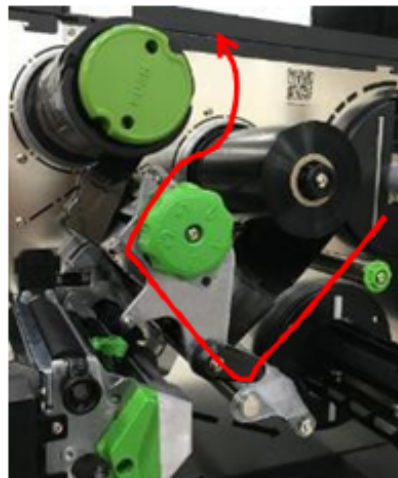

4. Thread ribbon below the ribbon guide bar through ribbon sensor slot and as the loading path printed on the printer.

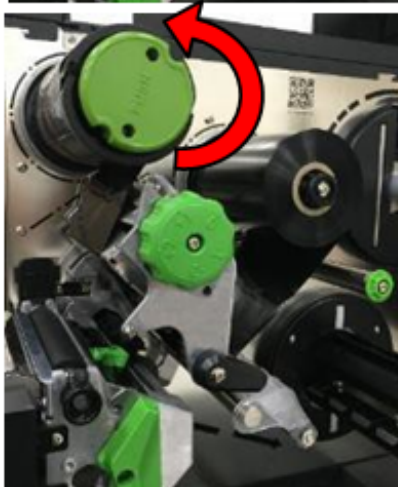

5. Wind the ribbon rewind spindle counterclockwise roughly 3~5 circles until the ribbon is smooth, properly stretched and wrinkle-free.

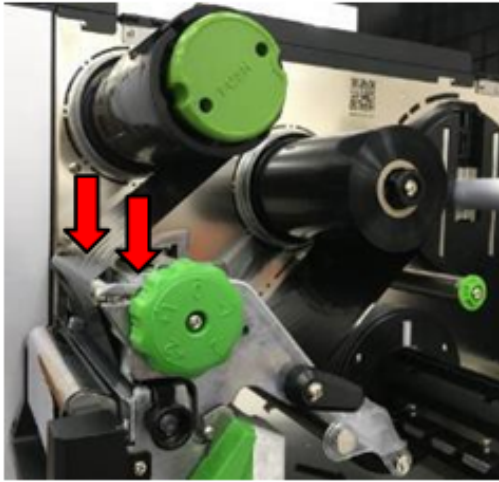

6. Close the print head mechanism by pushing down the both sides of the print head release lever.

Loading path for ribbon

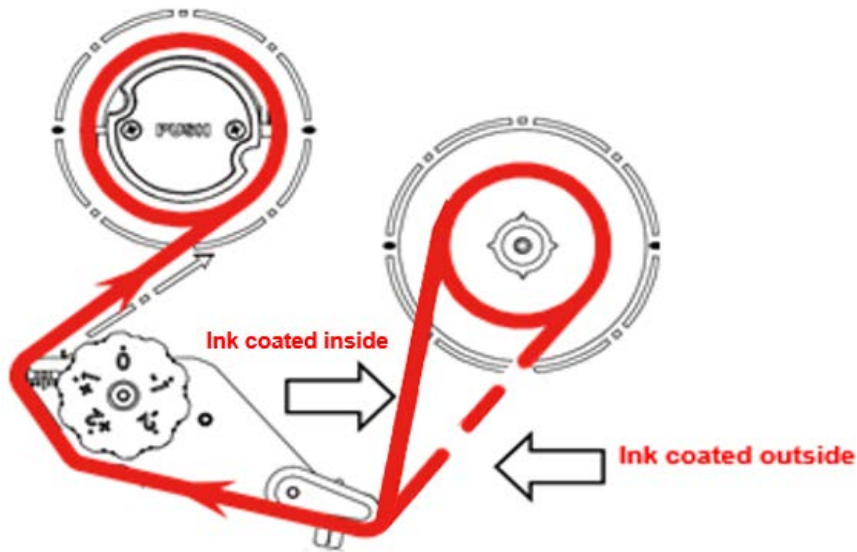

2.5.2 Remove Used Ribbon

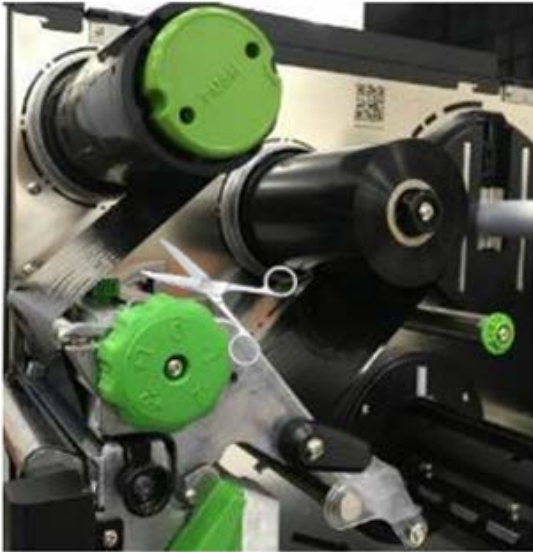

1. Break the ribbon between ribbon guide plate and the ribbon rewind spindle.

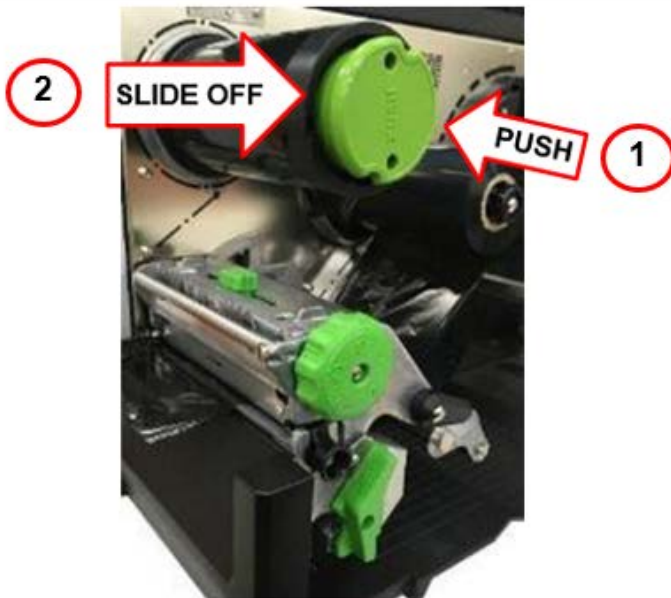

2. Push the ribbon release button and slide the ribbon off to release the ribbon on the ribbon rewind spindle at the same time.

2.6 Loading the Media



2.6.1 Loading the Media

1. Open the printer right side cover.

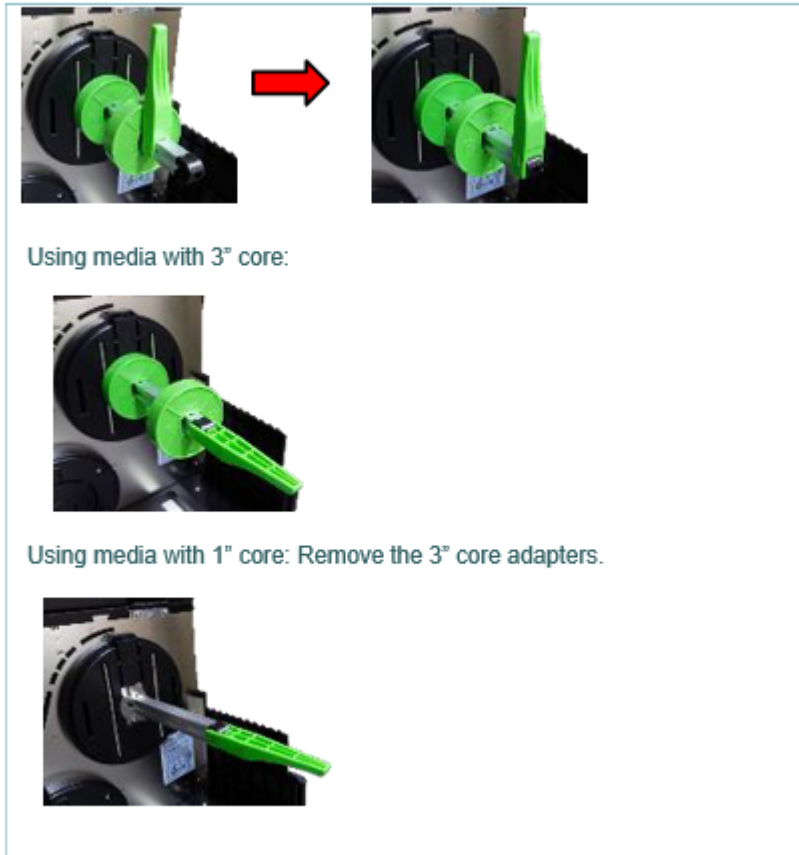

2. Move the label roll guard horizontally to the end of label spindle, then flip down the label roll guard.
For 1" spindle model, it supports the media with 1" core.



<p>For 1.5" spindle model</p> 	<p>For 1" spindle model</p> 
---	---

3. Place the media roll on the label supply spindle and use label roll guard to fix it.

Note:
The media end sensor is movable, which can detect the capacity of media and remind users to change the media roll.



4. Push the print head release lever and install the label through the media guide bar, damper, media sensor, and label guide to install the media.

5. Move the media sensor by adjusting the media sensor position adjustment knob, make sure the gap or black mark sensor is at the location where media gap/black mark will pass through for sensing.

Black mark sensor
(shown as ↓)

Gap sensor
(shown as ▽)





6. Adjust the label guide to fix the media position.

Note:

- * Please install the media through the media sensor.
- * The sensor location is marked by a triangle mark ▽ (gap sensor) and arrow mark ↓ (black mark sensor) at the sensor housing.
- * The media sensor position is movable, please make sure the gap or black mark is at the location where media gap/black mark will pass through for sensing.

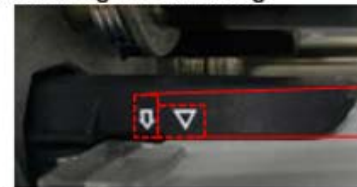

Black Mark Sensor

Gap Sensor



7. Close the print head mechanism on both sides and make sure the latches are engaged securely.
8. Set media sensor type and calibrate the selected sensor.

Note:

- * Please calibrate the gap/black marksensor when changing media.

2.7 Adjustment Knob

2.7.1 Print Head Pressure Adjustment Knob

The print head pressure adjustment knob has 5 levels of adjustment. Because the printer's paper alignment is to the left side of mechanism, different media widths require different pressure to print correctly. Therefore, it may require adjusting the pressure knob to get your best print quality. For example, if the label width is 4", adjust both print head pressure adjustment knobs to the same level. If the label is less than 2" wide, increase the left side print head pressure by rotating the adjustment knob clockwise and decrease the right-side pressure by rotating the adjustment knob counter-clockwise to level 1.

2.7.2 Print Head Burn Line Adjustment Knob

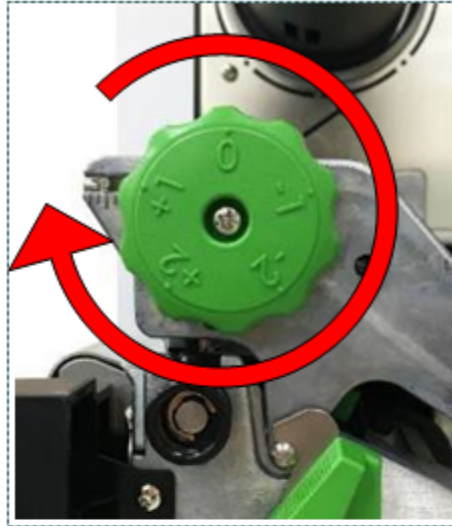

The print head pressure adjustment knob has 5 levels of adjustment. Because the printer's paper alignment is to the left side of mechanism, different media widths require the different pressure to print the label correctly. Therefore, it may require to adjust the print head pressure adjustment knob and get the best print quality.

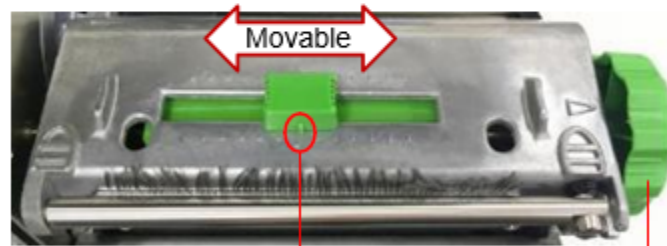

Print head pressure
position adjustment knob

Default setting

Print head pressure
adjustment knob

Note:

For the label width less than 2 inches, please fix the **Print head pressure adjustment knob** inside the edge of the label as possible (prevent the unnecessary friction between the print head and platen roller).

2.7.3 Ribbon Tension Adjustment Knob



The ribbon tension adjustment knob has 5 positions for adjustment. Because the printer's ribbon alignment is to the left side of mechanism, different ribbon or media widths require different tension to print correctly. Therefore, it may require to adjust the ribbon tension adjustment knob to get your best print quality.





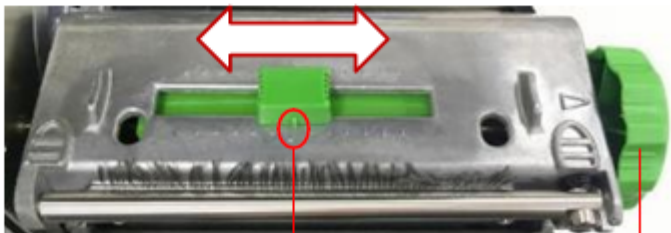

Ribbon Tension Adjustment Knob

2.7.4 Adjusting to Avoid Ribbon Wrinkles

This printer has been fully tested before delivery. There should be no ribbon wrinkle presented on the media for general-purpose printing application. Ribbon wrinkle is related to the media width, thickness, print head pressure balance, ribbon film characteristics, print darkness setting... etc. In case the ribbon wrinkle happens, please follow the instructions below to adjust the printer parts.

Adjustable Printer Parts	<p>Ribbon Tension Adjustment Knob has 5 positions for adjustment. Use flat blade driver to change the ribbon tension position.</p>
	
	<p>Ribbon Tension Adjustment Knob</p>
	<p>The Print Head Pressure Adjustment Knob has 5 levels of settings. Switch the Print head Pressure Adjustment Knob and cooperate with the Print Head Pressure Position Adjustment Knob to adjust the pressure and position on printhead.</p>
	
	<p>Print Head Pressure Adjustment Knob</p>
	
	<p>Print head pressure position adjustment knob Default setting Print head pressure adjustment knob</p>

Symptom	1. Wrinkle happens from label lower left to upper right direction (“^”)	2. Wrinkle happens from label lower right to upper left direction (“^”)
		
<p>Wrinkle Example</p>	<p>If the wrinkle on the label starts from the lower left side to upper right side, please do following adjustment.</p> <ol style="list-style-type: none"> 1. Switch the ribbon tension adjustment knob clockwise per 1 level and print the label again to check if the wrinkle is gone.  <ol style="list-style-type: none"> 2. If the ribbon tension adjustment knob has positioned on the level of innermost side but didn't improve the ribbon wrinkle, please switch the print head pressure position adjustment knob per 1 level and print the label again to check if the wrinkle is gone. 3. If the ribbon wrinkle still can't improve after switch the print head pressure position adjustment knob, please adjust the print head pressure adjustment knob per 1 level again to check if the wrinkle is gone. 	<p>If the wrinkle on the label starts from the lower right side to upper left side, please do following adjustment.</p> <ol style="list-style-type: none"> 1. Switch the ribbon tension adjustment knob counterclockwise per 1 level and print the label again to check if the wrinkle is gone.  <ol style="list-style-type: none"> 2. If the ribbon tension adjustment knob has positioned on the level of outermost side but didn't improve the ribbon wrinkle, please switch the print head pressure position adjustment knob per 1 level and print the label again to check if the wrinkle is gone. 3. If the ribbon wrinkle still can't improve after switch the print head pressure position adjustment knob, please adjust the print head pressure adjustment knob per 1 level again to check if the wrinkle is gone.

3. Printer/Menu/Sensor Function

3.1 Printer Function Overview

1. Printer Function could be found in Printer Configuration. "Printer Function" will be shown on the left side of the window.

Printer Function	Functions	Description
Calibrate Sensor	Calibrate Sensor	Detect media types and the size of the label
RTC Setup	RTC Setup	Synchronize printer with Real Time Clock on PC
Factory Default	Factory Default	Initialize the printer to default settings
Reset Printer	Reset Printer	Reboot printer
Print Test Page	Print Test Page	Print test page according to the specified label size and sensor type.
Configuration Page	Configuration Page	Print printer configurations
Dump Text	Dump Text	Activate the printer to dump mode
Ignore AUTO.BAS	Ignore AUTO.BAS	Ignore AUTO.BAS file when printer boot up.
Exit Line Mode	Exit Line Mode	Exit the line mode to page mode
Enter Line Mode	Enter Line Mode	Leave page mode and enter line mode

3.2 Setup Menu Overview

There are 6 categories for the menu. You can easily adjust the settings of the printer without connecting a computer. Please refer to the following sections for more details.



This "Setting" category can set up the printer settings for TSPL & ZPL2.



This "Sensor" option is used to calibrate the selected media sensor. We recommend calibrating the sensor before printing when changing the media.



This "Interface" option is used to set the printer interface settings.



This "Advanced" option is used to set the printer LCD settings, initialization, cutter type, media low warning setting %...etc.



This "File Manager" option is used to check/ manage the printer's available memory.



This "Diagnostic" option is used to review the printer to troubleshoot problems and other issues.

3.3 Advanced Menu

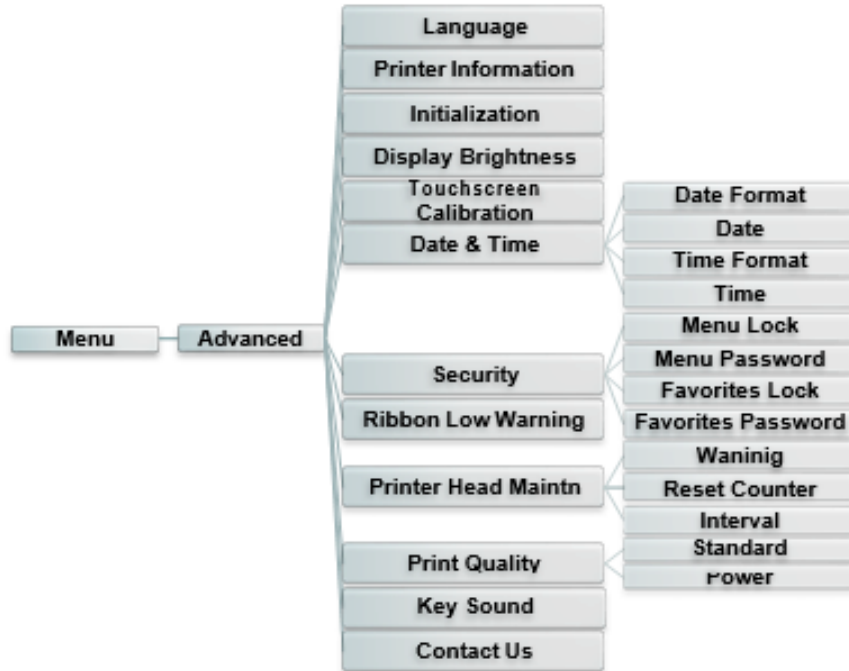

Item	Description	Default
Language	This item is used to setup the language on display.	English
Printer Information	This feature is used to check the printer serial number, printed mileage (m), printed labels (pcs) and cutting counter.	N/A
Initialization	This feature is used to restore printer settings to defaults.	N/A
Display Brightness	This item is used to setup the brightness for display. (Range 0~100)	50

Touchscreen Calibration	This item is used to calibrate the center of the cross for best result for touchscreen.	N/A	
Date & Time	This item is used to setup the date and time on display.	N/A	
Security	This feature is used to set the password for locking the menu or favorites. The default password is 8888.	Disable	
Ribbon Low Warning	This item is used to set the warning for ribbon low. For example, if setting value is 30m, when ribbon capacity was lower than 30m, the  will be shown in red.	30m	
Printer Head Maintn	This item is used to check print head status and to set the settings for print head care.		N/A
	Item	Description	
	Warning	This item is used to enable/disable the print head clean warning. If enable this feature, once print head has been reached the setting mileage then the warning icon will be shown on printer UI for reminding user to clean the print head. The default setting is disable.	
	Reset Counter	This item is used to reset the print head clean warning mileage after cleaned print head.	
Interval	This item is used to set the expected mileage for reminding user to clean the print head. You have to enable the "TPH warning lock" for use. The default setting is 1 km.		
Print Quality	This item is used to select the print quality to standard/ power mode.	Standard	
Key Sound	This item is used to open/close the key sound.	ON	
Contact us	This feature is used to check the contact information for tech support service	N/A	

3.4 Sensor Overview

This option is used to calibrate the selected sensor. We recommend calibrating the sensor before printing when changing the media.

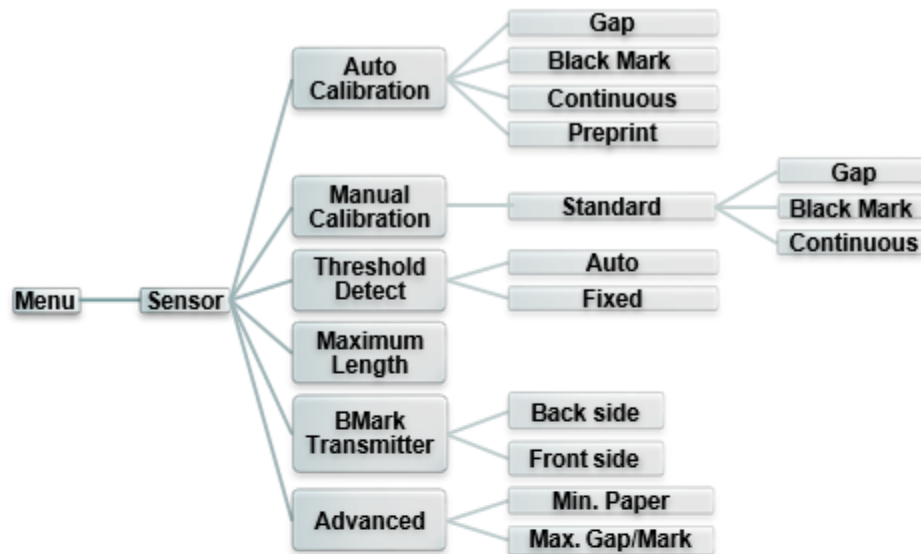

Item	Description	Default
Auto Calibration	This option is used to set the media sensor type and calibrate the selected sensor automatically. Printer will feed 2 to 3 gap labels to calibrate the sensor sensitivity automatically.	N/A
Manual setup	In case "Automatic" cannot apply to the media, please use "Manual" function to set the paper length and gap/bline size then scan the backing/mark to calibrate the sensor sensitivity. Note: The "Media Capacity" item is used to calibrate the media capacity sensor %.	N/A
Threshold Detect	This option is used to set sensor sensitivity in fixed or auto.	Auto
Maximum Length	This option is used to set the maximum length for label calibration.	254 mm
BMark Transmitter	This option is used to set upper black mark sensor or the lower black sensor as the main transmitter.	Back side
Advanced	This function can set the minimum paper length and maximum gap/bline length for auto-calibrate the sensor sensitivity.	0 mm

4. Diagnostics

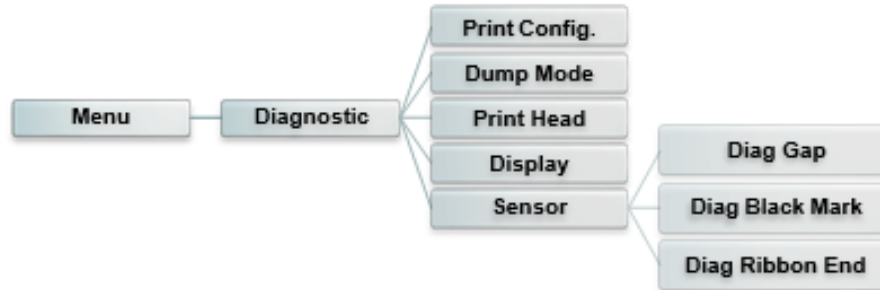

Item	Description																																																									
	This feature is used to print current printer configuration to the label. On the configuration printout, there is a print head test pattern, which is useful for checking if there is any dot damage on the print head heater element.																																																									
	<div style="border: 1px solid black; padding: 5px;"> <p style="text-align: center; margin: 0;">Self-test printout</p> <hr/> <p style="text-align: center; margin: 0;">SYSTEM INFORMATION</p> <table style="width: 100%; border-collapse: collapse;"> <tr> <td style="width: 60%;">MODEL: XXXXXX</td> <td style="width: 40%;">Model name</td> </tr> <tr> <td>FIRMLARE: X.XX</td> <td>F/W version</td> </tr> <tr> <td>CHECKSUM: XXXXXXXX</td> <td>Firmware checksum</td> </tr> <tr> <td>S/N: XXXXXXXXXXXX</td> <td>Printer S/N</td> </tr> <tr> <td>TCF: NO</td> <td>TSC configuration file</td> </tr> <tr> <td>DATE: 1970/01/01</td> <td>System date</td> </tr> <tr> <td>TIME: 00:04:18</td> <td>System time</td> </tr> <tr> <td>NON-RESET: 110 m (TPH)</td> <td rowspan="2">Printed mileage (meter)</td> </tr> <tr> <td>RESET: 110 m (TPH)</td> </tr> <tr> <td>NON-RESET: 0 (CUT)</td> <td rowspan="2">Cutting counter</td> </tr> <tr> <td>RESET: 0 (CUT)</td> </tr> </table> <hr/> <p style="text-align: center; margin: 0;">PRINTING SETTING</p> <table style="width: 100%; border-collapse: collapse;"> <tr> <td style="width: 60%;">SPEED: 5 IPS</td> <td style="width: 40%;">Print speed (inch/sec)</td> </tr> <tr> <td>DENSITY: 8.0</td> <td>Print darkness</td> </tr> <tr> <td>WIDTH: 4.00 INCH</td> <td>Label size (inch)</td> </tr> <tr> <td>HEIGHT: 4.00 INCH</td> <td></td> </tr> <tr> <td>GAP: 0.00 INCH</td> <td>Gap distance (inch)</td> </tr> <tr> <td>INTENSION: 5</td> <td>Gap/black mark sensor intension</td> </tr> <tr> <td>CODEPAGE: 850</td> <td>Code page</td> </tr> <tr> <td>COUNTRY: 001</td> <td>Country code</td> </tr> </table> <hr/> <p style="text-align: center; margin: 0;">Z SETTING</p> <table style="width: 100%; border-collapse: collapse;"> <tr> <td style="width: 60%;">DARKNESS: 16.0</td> <td style="width: 40%;">ZPL setting information</td> </tr> <tr> <td>SPEED: 4 IPS</td> <td>Print speed (inch/sec)</td> </tr> <tr> <td>WIDTH: 4.00 INCH</td> <td>Label size</td> </tr> <tr> <td>TILOE: 7EH (")</td> <td>Control prefix</td> </tr> <tr> <td>CARET: 5EH (^)</td> <td>Format prefix</td> </tr> <tr> <td>DELIMITER: 2CH (,)</td> <td>Delimiter prefix</td> </tr> <tr> <td>POWER UP: NO MOTION</td> <td>Printer power up motion</td> </tr> <tr> <td>HEAD CLOSE: NO MOTION</td> <td>Printer head close motion</td> </tr> </table> <hr/> <p style="text-align: center; margin: 0;">RS232 SETTING</p> <table style="width: 100%; border-collapse: collapse;"> <tr> <td style="width: 60%;">BAUD: 9600</td> <td rowspan="4">RS232 serial port configuration</td> </tr> <tr> <td>PARITY: NONE</td> </tr> <tr> <td>DATA BIT: 8</td> </tr> <tr> <td>STOP BIT: 1</td> </tr> </table> </div> <p style="margin-top: 10px;">Print Config.</p>	MODEL: XXXXXX	Model name	FIRMLARE: X.XX	F/W version	CHECKSUM: XXXXXXXX	Firmware checksum	S/N: XXXXXXXXXXXX	Printer S/N	TCF: NO	TSC configuration file	DATE: 1970/01/01	System date	TIME: 00:04:18	System time	NON-RESET: 110 m (TPH)	Printed mileage (meter)	RESET: 110 m (TPH)	NON-RESET: 0 (CUT)	Cutting counter	RESET: 0 (CUT)	SPEED: 5 IPS	Print speed (inch/sec)	DENSITY: 8.0	Print darkness	WIDTH: 4.00 INCH	Label size (inch)	HEIGHT: 4.00 INCH		GAP: 0.00 INCH	Gap distance (inch)	INTENSION: 5	Gap/black mark sensor intension	CODEPAGE: 850	Code page	COUNTRY: 001	Country code	DARKNESS: 16.0	ZPL setting information	SPEED: 4 IPS	Print speed (inch/sec)	WIDTH: 4.00 INCH	Label size	TILOE: 7EH (")	Control prefix	CARET: 5EH (^)	Format prefix	DELIMITER: 2CH (,)	Delimiter prefix	POWER UP: NO MOTION	Printer power up motion	HEAD CLOSE: NO MOTION	Printer head close motion	BAUD: 9600	RS232 serial port configuration	PARITY: NONE	DATA BIT: 8	STOP BIT: 1
MODEL: XXXXXX	Model name																																																									
FIRMLARE: X.XX	F/W version																																																									
CHECKSUM: XXXXXXXX	Firmware checksum																																																									
S/N: XXXXXXXXXXXX	Printer S/N																																																									
TCF: NO	TSC configuration file																																																									
DATE: 1970/01/01	System date																																																									
TIME: 00:04:18	System time																																																									
NON-RESET: 110 m (TPH)	Printed mileage (meter)																																																									
RESET: 110 m (TPH)																																																										
NON-RESET: 0 (CUT)	Cutting counter																																																									
RESET: 0 (CUT)																																																										
SPEED: 5 IPS	Print speed (inch/sec)																																																									
DENSITY: 8.0	Print darkness																																																									
WIDTH: 4.00 INCH	Label size (inch)																																																									
HEIGHT: 4.00 INCH																																																										
GAP: 0.00 INCH	Gap distance (inch)																																																									
INTENSION: 5	Gap/black mark sensor intension																																																									
CODEPAGE: 850	Code page																																																									
COUNTRY: 001	Country code																																																									
DARKNESS: 16.0	ZPL setting information																																																									
SPEED: 4 IPS	Print speed (inch/sec)																																																									
WIDTH: 4.00 INCH	Label size																																																									
TILOE: 7EH (")	Control prefix																																																									
CARET: 5EH (^)	Format prefix																																																									
DELIMITER: 2CH (,)	Delimiter prefix																																																									
POWER UP: NO MOTION	Printer power up motion																																																									
HEAD CLOSE: NO MOTION	Printer head close motion																																																									
BAUD: 9600	RS232 serial port configuration																																																									
PARITY: NONE																																																										
DATA BIT: 8																																																										
STOP BIT: 1																																																										

	<div style="border: 1px solid black; padding: 5px;"> <p style="text-align: center;">----- DRAM FILE (0 FILES) -----</p> <p style="text-align: center;">PHYSICAL XXXX KBYTES AVAILABLE XXXX KBYTES -----</p> <p style="text-align: center;">FLASH FILE (0 FILES) -----</p> <p style="text-align: center;">PHYSICAL XXXX KBYTES AVAILABLE XXXX KBYTES -----</p>  <p style="text-align: right;">Print head check pattern</p> <p style="color: blue;">Note: Checking dot damage requires 4" wide paper width.</p> </div> <p style="margin-top: 10px;">Numbers of download files Total & available memory space</p>
<p style="color: blue;">Dump Mode</p>	<p>Captures the data from the communications port and prints out the data received by printer. In the dump mode, all characters will be printed in 2 columns. The left side characters are received from your system and right-side data are the corresponding hexadecimal value of the characters. It allows users or engineers to verify and debug the program.</p> <div style="border: 1px solid black; padding: 5px; margin: 10px 0;"> <pre> DOWNLOA 0D 0A 44 4F 57 4E 4C 4F 4I D „TEST2. 44 20 22 54 45 53 54 32 2E DAT“,5,CL 44 41 54 22 2C 35 2C 43 4C S DOWNLO 53 0D 0A 44 4F 57 4E 4C 4F AD F,„TES 41 44 20 46 2C 22 54 45 53 T4.DAT“,5 54 34 2E 44 41 54 22 2C 35 ,CLS DOW 2C 43 4C 53 0D 0A 44 4F 57 NLOAD „TE 4E 4C 4F 41 44 20 22 54 45 ST2.DAT“, 53 54 32 2E 44 41 54 22 2C 5,CLS DO 35 2C 43 4C 53 0D 0A 44 4F WNLOAD F, 57 4E 4C 4F 41 44 20 46 2C „TEST4.DA 22 54 45 53 54 34 2E 44 41 T“,S,CLS 54 22 2C 35 2C 43 4C 53 0D DOWNLOAD 0A 44 4F 57 4E 4C 4F 41 44 „TEST2.D 20 22 54 45 53 54 32 2E 44 AT“,S,CLS 41 54 22 2C 35 2C 43 4C 53 DOWNLOAD 0D 0A 44 4F 57 4E 4C 4F 4I D F,„TEST 44 20 46 2C 22 54 45 53 54 4.DAT“,S, 34 2E 44 41 54 22 2C 35 2C CLS 43 4C 53 0D 0A </pre> </div> <p style="color: blue;">ASCII Data ←</p> <p style="color: blue;">Hexadecimal data related to leftcolumn of ASCII data</p> <p style="color: blue;">Note: Dump mode requires 4" wide paper width.</p>
<p style="color: blue;">Print Head</p>	<p>This feature is used to check print head's temperature and bad dots.</p>
<p style="color: blue;">Display</p>	<p>This feature is used to check LCD's color state.</p>
<p style="color: blue;">Sensor</p>	<p>This feature is used to check sensors intensity and reading state.</p>

5. Troubleshooting

The following guide lists the most common problems that may be encountered when operating this printer. If the printer still does not function after all suggested solutions have been invoked, please contact "Panduit ID Technical Support".

Problem	Possible Cause	Recovery Procedure
Power indicator does not illuminate	<ul style="list-style-type: none"> * The power cord is not properly connected. * The power switch is off. 	<ul style="list-style-type: none"> * Plug the power cord in printer and outlet. * Switch the printer on.
Carriage Open	<ul style="list-style-type: none"> * The printer carriage is open. 	<ul style="list-style-type: none"> * Please close the print carriage.
Not Printing	<ul style="list-style-type: none"> * Check if interface cable is well connected to the interface connector. * The port specified in the Windows driver is not correct. 	<ul style="list-style-type: none"> * Re-connect cable to interface or change a new cable. * Select the correct printer port in the driver. * Clean the printhead. * Printhead's harness connector is not well connected with printhead. Turn off the printer and plug the connector again. * Check your program if there is a command PRINT at the end of the file and there must have CRLF at the end of each command line.
No print on the label	<ul style="list-style-type: none"> * Label or ribbon is not loaded correctly. * Use wrong type paper or ribbon 	<ul style="list-style-type: none"> * Follow the instructions in loading the media and ribbon. * Ribbon and media are not compatible. * Verify the ribbon-inked side. * The print density setting is incorrect.
No Ribbon	<ul style="list-style-type: none"> * Running out of ribbon. * The ribbon is installed incorrectly. 	<ul style="list-style-type: none"> * Supply a new ribbon roll. * Please refer to the steps in user's manual to reinstall the ribbon.
No Paper	<ul style="list-style-type: none"> * Running out of label. * The label is installed incorrectly. * Gap/black mark sensor is not calibrated. 	<ul style="list-style-type: none"> * Supply a new label roll. * Please refer to the steps in user's manual to reinstall the label roll. * Calibrate the gap/black mark sensor.
Paper Jam	<ul style="list-style-type: none"> * Gap/black mark sensor is not set properly. * Make sure label size is set properly. * Labels may be stuck inside the printer mechanism. 	<ul style="list-style-type: none"> * Calibrate the media sensor. * Set media size correctly. * Remove the stuck label inside the printer mechanism.
Take Label	<ul style="list-style-type: none"> * Peel function is enabled. 	<ul style="list-style-type: none"> * If the peeler module is installed, please remove the label. * If there is no peeler module in front of the printer, please switch off the printer and install it. * Check if the connector is plugging correctly.
Can't downloading the file to memory (FLASH / DRAM/CARD)	<ul style="list-style-type: none"> * The space of memory is full. 	<ul style="list-style-type: none"> * Delete unused files in the memory.

microSD card is unable to use	<ul style="list-style-type: none"> * microSD card is damaged. * microSD card doesn't insert correctly. * Use the non-approved SD card manufacturer. 	<ul style="list-style-type: none"> * Use the supported capacity microSD card. * Insert the microSD card again. * The supported microSD card spec and the approved microSD card manufacturers.
Poor Print Quality	<ul style="list-style-type: none"> * Ribbon and media are loaded incorrectly. * Dust or adhesive accumulation on the print head. * Print density is not set properly. * Printhead element is damaged. * Ribbon and media are incompatible. * The printhead pressure is not set properly. 	<ul style="list-style-type: none"> * Reload the supply. * Clean the print head. * Clean the platen roller. * Adjust the print density and print speed. * Run printer self-test and check the print head test pattern if there is dot missing in the pattern. * Change proper ribbon or proper label media. * Adjust the printhead pressure adjustment knob. * The release lever does not latch the printhead properly.
Missing printing on the left or right side of label	<ul style="list-style-type: none"> * Wrong label size setup. 	<ul style="list-style-type: none"> * Set the correct label size.
Gray line on the blank label	<ul style="list-style-type: none"> * The print head is dirty. * The platen roller is dirty. 	<ul style="list-style-type: none"> * Clean the print head. * Clean the platen roller.
Irregular printing	<ul style="list-style-type: none"> * The printer is in Hex Dump mode. * The RS-232 setting is incorrect. 	<ul style="list-style-type: none"> * Turn off and on the printer to skip the dump mode. * Re-set the Rs-232 setting.
Label feeding is not stable (skew) when printing	<ul style="list-style-type: none"> * The media guide does not touch the edge of the media. 	<ul style="list-style-type: none"> * If the label is moving to the right side, please move the label guide to left. * If the label is moving to the left side, please move the label guide to right.
Skip labels when printing	<ul style="list-style-type: none"> * Label size is not specified properly. * Sensor sensitivity is not set properly. * The media sensor is covered with dust. 	<ul style="list-style-type: none"> * Check if label size is setup correctly. * Calibrate the sensor by Auto Gap or Manual Gap options. * Clear the GAP/Black mark sensor by blower.
Wrinkle Problem	<ul style="list-style-type: none"> * Printhead pressure is incorrect. * Ribbon installation is incorrect. * Media installation is incorrect. * Print density is incorrect. * Media feeding is incorrect. 	<ul style="list-style-type: none"> * Please set the suitable density to have good print quality. * Make sure the label guide touches the edge of the media guide.
RTC time is incorrect when reboot the printer	<ul style="list-style-type: none"> * The battery has run down. 	<ul style="list-style-type: none"> * Check if there is a battery on the main board.
The left side printout position is incorrect	<ul style="list-style-type: none"> * Wrong label size setup. * The parameter Shift X in LCD menu is incorrect. 	<ul style="list-style-type: none"> * Set the correct label size. * Press [Menu] → [Setting] → [Shift X] to fine tune the parameter of Shift X.

<p>The printing position of small label is incorrect</p>	<ul style="list-style-type: none">• Media sensor sensitivity is not set properly.• Label size is incorrect.• The parameter Shift Y in the LCD menu is incorrect.• The vertical offset setting in the driver is incorrect.	<ul style="list-style-type: none">• Calibrate the sensor sensitivity again.• Set the correct label size and gap size.• Press [Menu] → [Setting] → [Shift Y] → to fine tune the parameter of Shift Y. 
--	--	---

6. Maintenance

This session presents the methods to maintain your printer.

- **For Cleaning**
Depending on the media used, the printer may accumulate residues (media dust, adhesives, etc.) as a by-product of normal printing. To maintain the best printing quality, you should remove these residues by cleaning the printer periodically. Regularly clean the print head and supply sensors once change a new media to keep the printer at the optimized performance and extend printer life.
- **For Disinfecting**
Sanitize your printer to protect yourself and others and can help prevent the spread of viruses.
- **Important**
 - Set the printer power switch to O (Off) prior to performing any cleaning or disinfecting tasks. Leave the power cord connected to keep the printer grounded and to reduce the risk of electrostatic damage.
 - Do not wear rings or other metallic objects while cleaning any interior area of the printer.
 - Use only the cleaning agents recommended in this document. Use of other agents may damage the printer and void its warranty.
 - Do not spray or drip liquid cleaning solutions directly into the printer. Apply the solution on a clean lint-free cloth and then apply the dampened cloth to the printer.
 - Do not use canned air in the interior of the printer as it can blow dust and debris onto sensors and other critical components.
 - Only use a vacuum cleaner with a nozzle and hose that are conductive and grounded to drain off static build up.
 - All reference in these procedures for use of isopropyl alcohol requires that a 99% or greater isopropyl alcohol content be used to reduce the risk of moisture corrosion to the printhead.
 - Do not touch printhead by hand. If you touch it carelessly, please use 99% Isopropyl alcohol to clean it.
 - Always taking personal precaution when using any cleaning agent.
- **Cleaning Tools**
 - Cotton swab
 - Lint-free cloth
 - Brush with soft non-metallic bristles
 - Vacuum cleaner
 - 75% Ethanol (for disinfecting)
 - 99% Isopropyl alcohol (for printhead and platen roller cleaning)
 - Genuine printhead cleaning pen
 - Mild detergent (without chlorine)

Printer Part	Method	Interval
Print Head	<ol style="list-style-type: none"> 1. Always turn off the printer before cleaning the printhead. 2. Allow the printhead to cool for a minimum of one minute. 3. Use a cotton swab and 99% Isopropyl Alcohol or genuine print head cleaning pen to clean the print head surface. 	Clean the print head when changing a new label roll.
Platen Roller	<ol style="list-style-type: none"> 1. Turn off the printer. 2. Rotate the platen roller and wipe it thoroughly with the lint-free 99% Isopropyl Alcohol. 	Clean the platen roller when changing a new label roll
Peel Bar	Use the lint-free cloth with 99% Isopropyl Alcohol to wipe it.	As needed
Sensor	Use a brush with soft non-metallic bristles or a vacuum cleaner, described above, to remove paper dust. The upper and lower media sensors should be cleaned to ensure reliable Top of Form and Paper Out sensing.	Monthly
Exterior	Clean the exterior surfaces with a clean, lint-free cloth (water-dampened cloth). If necessary, use a mild detergent or desktop cleaning solution then use the 75% Ethanol to wipe it.	As needed
Interior	Clean the interior of the printer by removing any dirt and lint with a vacuum cleaner, as described above, or use a brush with soft non-metallic bristles then use the 75% Ethanol to wipe it.	As needed