

1 Scellement des tiges & fixation de la base

Install anchor J-Bolts in concrete foundation & fix the base

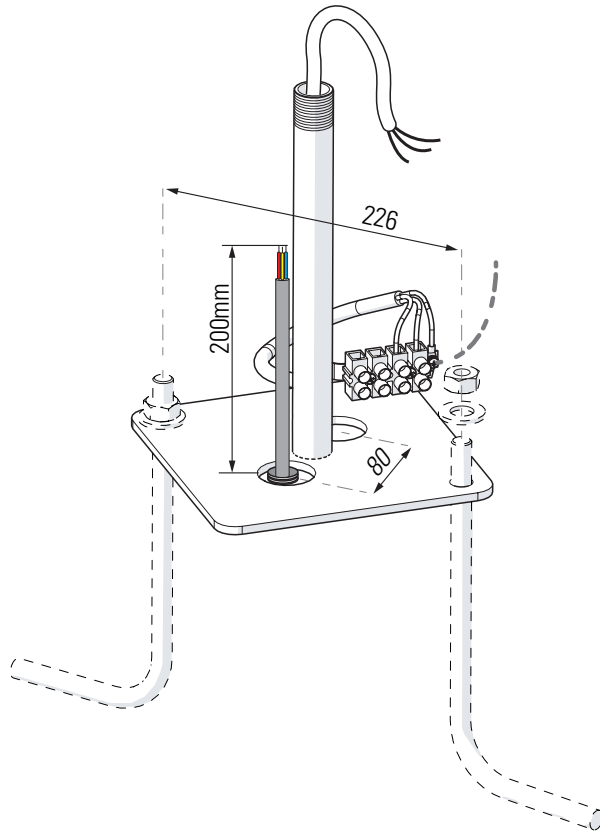

2 Raccordement électrique

Connect electrical wires

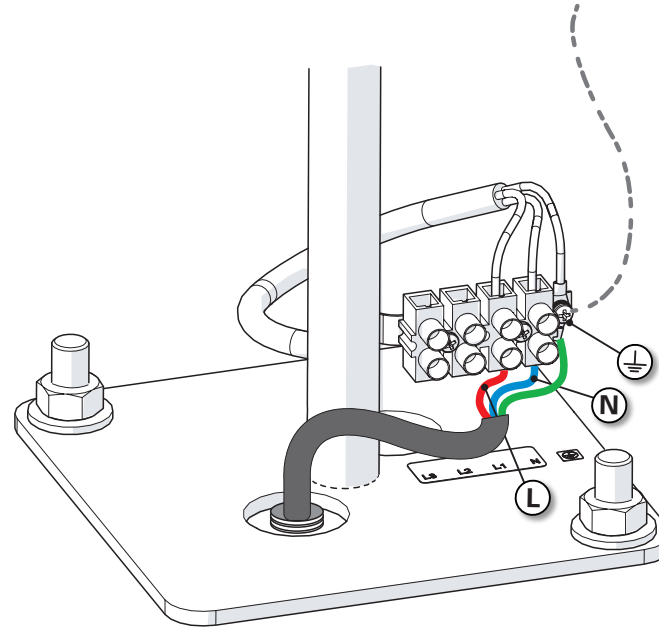

3 Engager le câble dans la fonderie

Engage the cable through the casting part

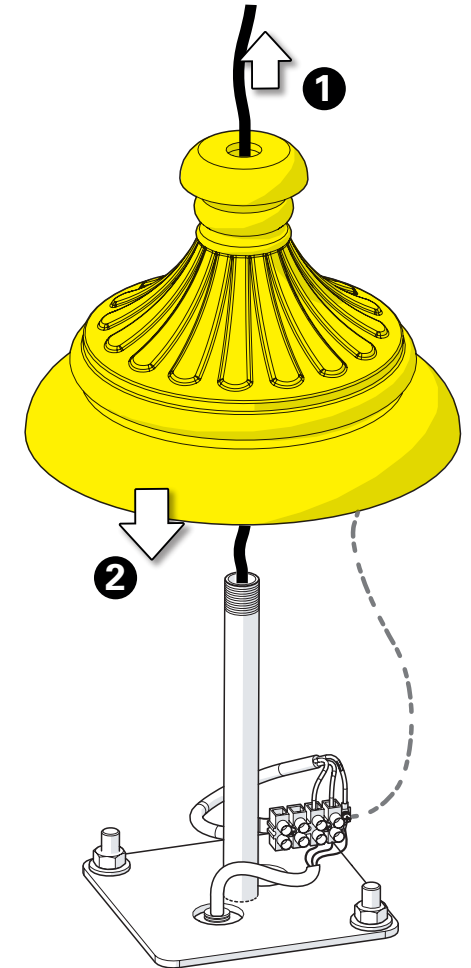

4 Extraire la verrine
Extract the glass

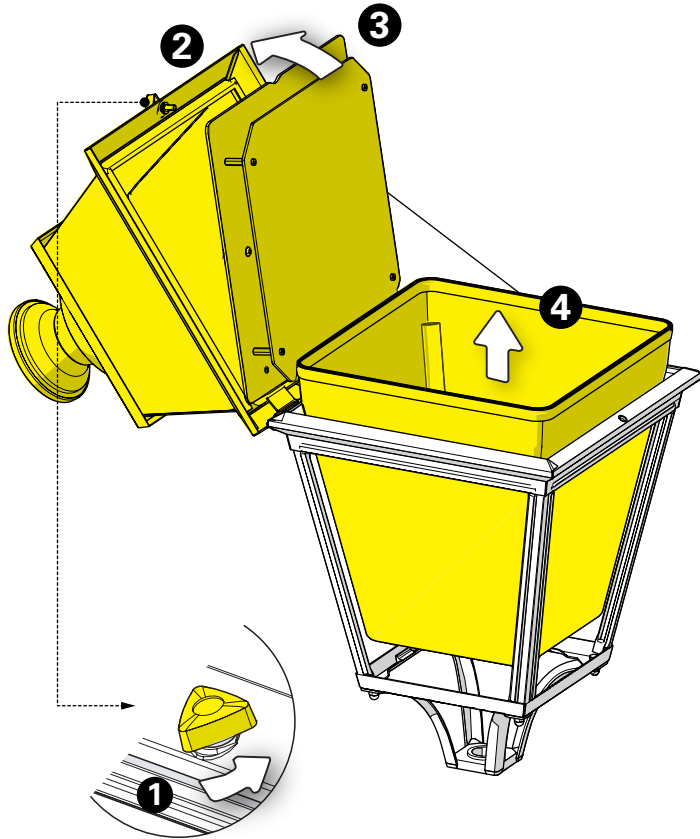

5 Montage de la tête sur l'embase
Mount the luminaire on the base

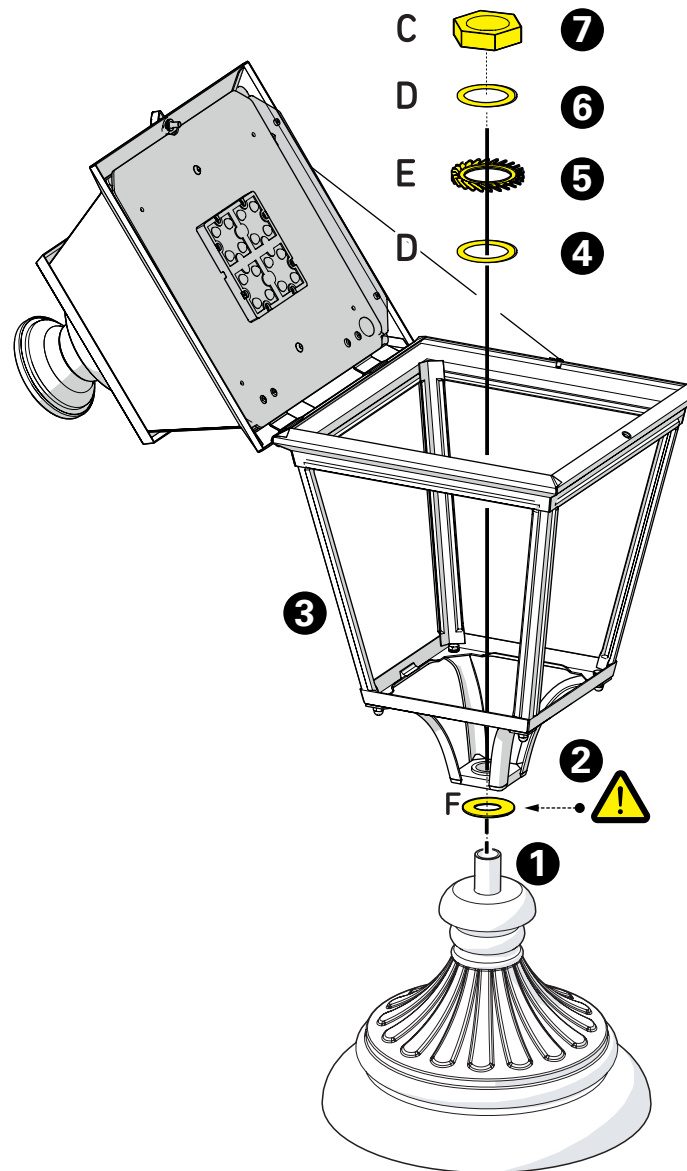

6 Montage du presse-étoupe
Mount the cable-gland

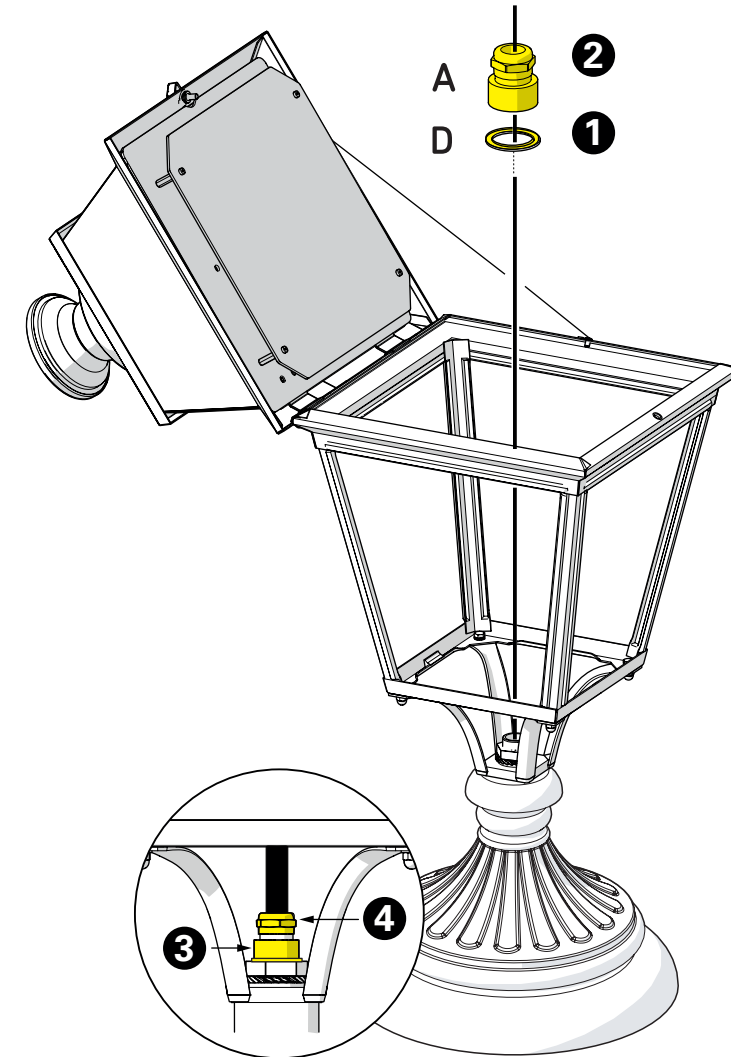

7 Montage de la verrine & passage du câble
Put in place the glass and insert cable into the conduit

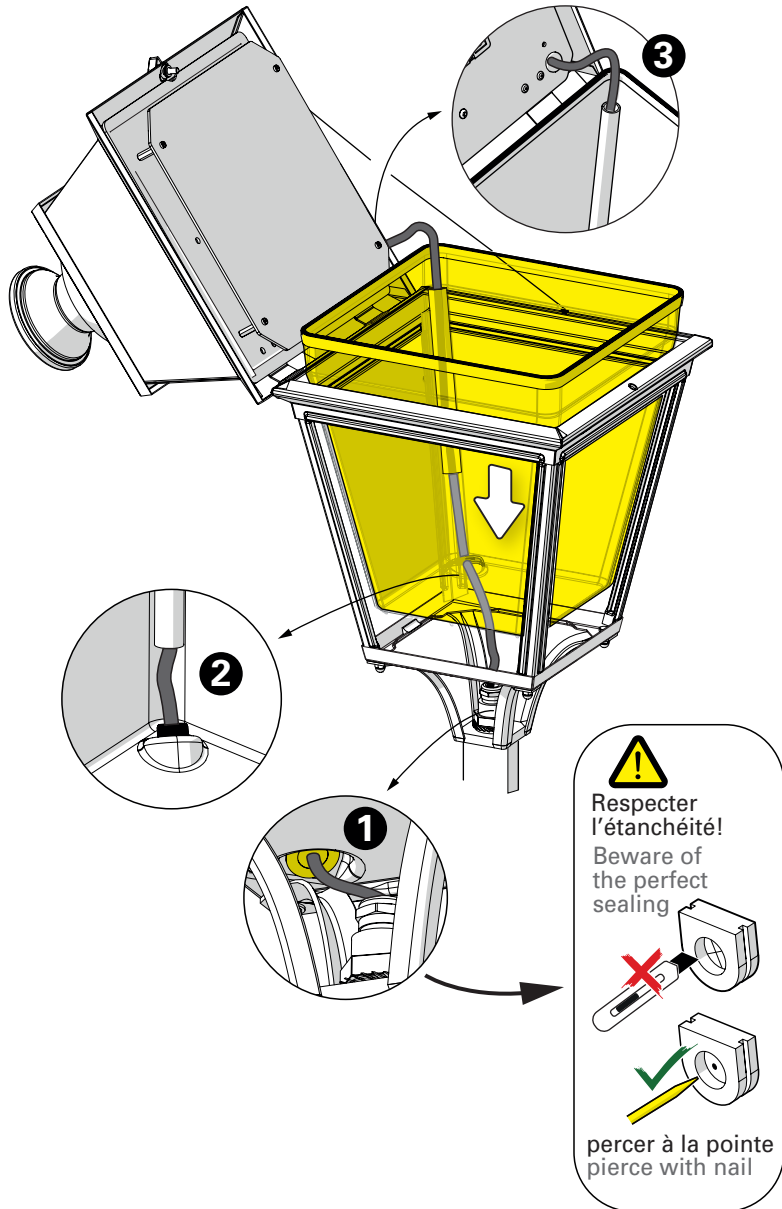

8 Raccordement électrique
Connect electrical wires

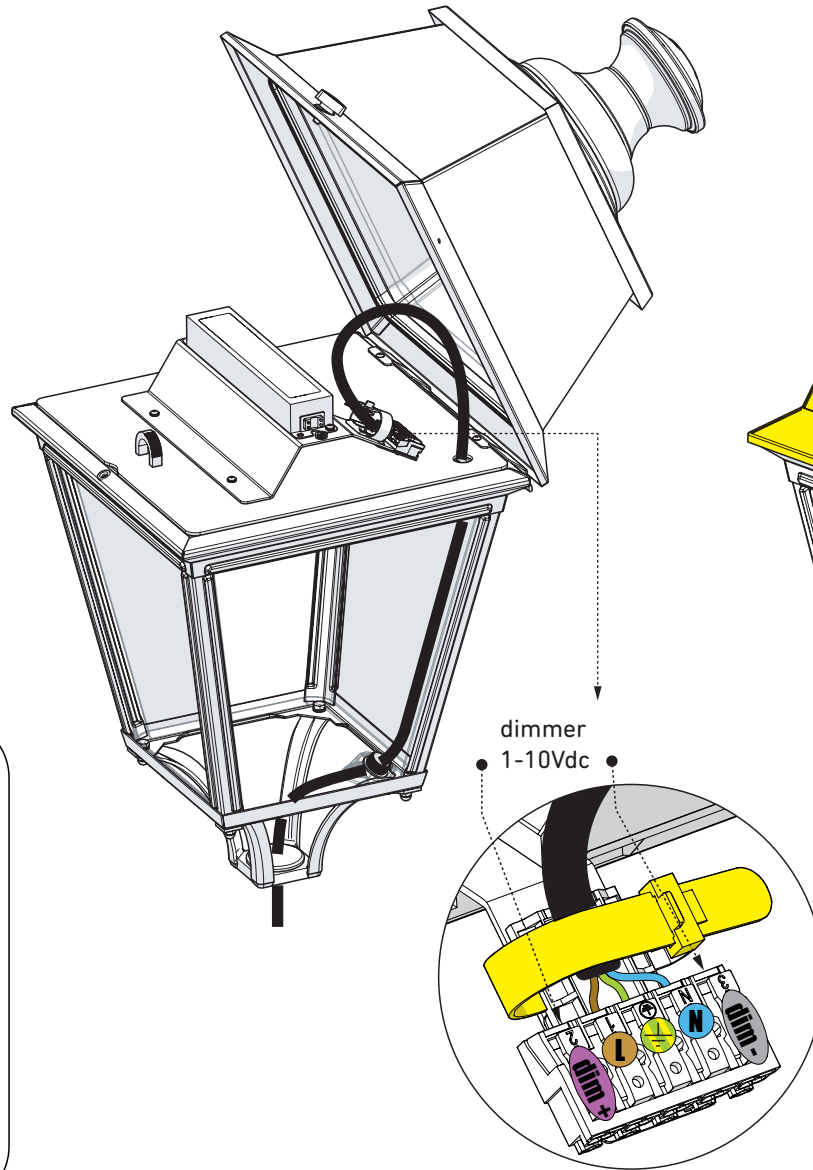

9 Fermeture de la lanterne
Close the luminaire head

