



Harmony™ eXLhoist Compact

ZART8LS



ZARB10WS

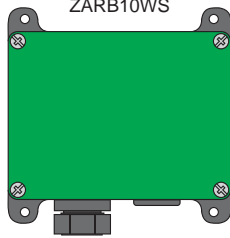

ZARB10WSP

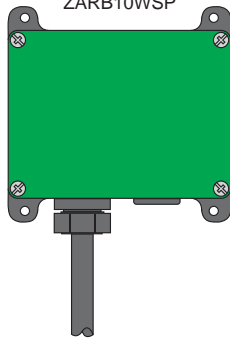

⚡ ⚠ DANGER

HAZARD OF ELECTRIC SHOCK, EXPLOSION OR ARC FLASH

- Disconnect all power from all equipment including connected devices, prior to removing any covers or doors, or installing or removing any accessories, hardware, cables, or wires except under the specific conditions specified in the appropriate hardware guide for this equipment.
- Always use a properly rated voltage sensing device to confirm the power is off where and when indicated.
- Replace and secure all covers, accessories, hardware, cables, and wires and confirm that a proper ground connection exists before applying power to the unit.
- Use only the specified voltage when operating this equipment and any associated products.

Failure to follow these instructions will result in death or serious injury.

⚠ WARNING

UNINTENDED EQUIPMENT OPERATION

- Use appropriate safety interlocks where personnel and/or equipment hazards exist.
- Install and operate this equipment in an enclosure appropriately rated for its intended environment.
- Do not disassemble, repair, or modify this equipment.
- Do not connect any wiring to unused connections, or to connections designated as Not Connected (N.C.).
- Switch off the transmitter when not operating the unit to avoid accidental operations of motions push buttons.

Failure to follow these instructions can result in death, serious injury, or equipment damage.

Electrical equipment should be installed, operated, serviced, and maintained only by qualified personnel. No responsibility is assumed by Schneider Electric for any consequences arising out of the use of this material. You can download our technical user guide file from our web site at www.schneider-electric.com.

⚠ WARNING

UNINTENDED EQUIPMENT OPERATION

Power line must be wired and protected with fuse or thermal magnetic switch (ex: Schneider-Electric GB2) in compliance with local and national regulatory requirements for the rated current and voltage of the particular equipment.

Failure to follow these instructions can result in death, serious injury, or equipment damage.

This device complies with part 15 of the FCC Rules and Industry Canada licence-exempt RSS standard(s). Operation is subject to the following two conditions:

- 1) This device may not cause harmful interference.
- 2) this device must accept any interference received, including interference that may cause undesired operation.

Le présent appareil est conforme aux CNR d'Industrie Canada applicables aux appareils radio exempts de licence. L'exploitation est autorisée aux deux conditions suivantes :

- 1) L'appareil ne doit pas produire de brouillage.
- 2) L'utilisateur de l'appareil doit accepter tout brouillage radioélectrique subi, même si le brouillage est susceptible d'en compromettre le fonctionnement.

Main Characteristics

Dimensions

Transmitter ZART8LS

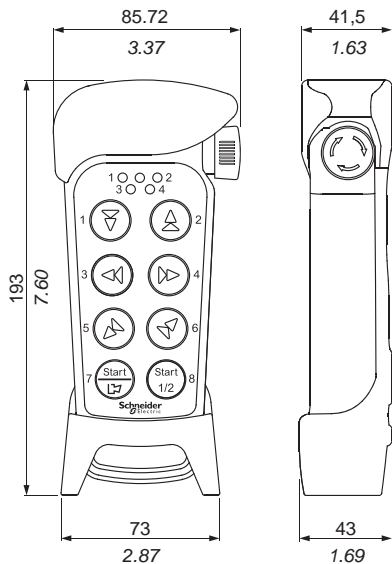

Receiver ZARB10WS

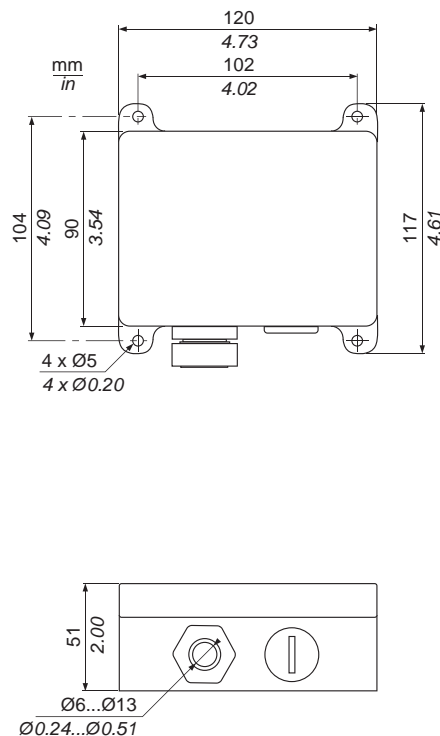

Receiver ZARB10WSP

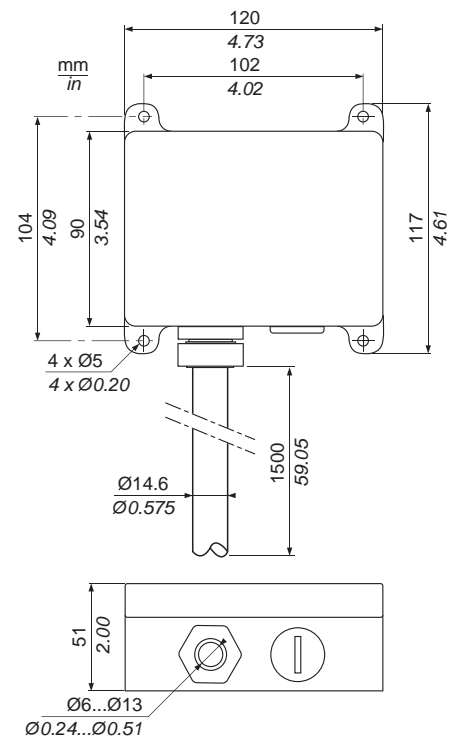

Technical specifications**Transmitter ZART8LS**

Specification	Value
Number of buttons	8 x 2-step buttons
Battery	3 x 1.5 Vdc AAA / LR03 in battery pack ZARC704 ⁽¹⁾
Radio communication	Simplex
Dimensions	85 x 193 x 43 mm (3.4 x 7.7 x 1.7 in)
Weight	300 g / 0.7 lbs
Radio Frequency band	2405...2480 MHz
Number of radio frequency channels	16 (channel 11...26) ⁽²⁾
Operating time (continuous usage)	Approximately 100 h. with alkaline
Degree of protection	IP65
Operating temperature	-20...55 °C (-4...130 °F)

(1) Alkaline batteries are provided with the transmitter ZART8LS.

(2) To know what is the radio frequency channel on your system, refer to the indicate radio frequency channel procedure (see page 6/8)

Receiver ZARB10WS●

Specification	Value
Number of stop relays	2, potential free ⁽¹⁾
Stop relays maximum resistive load	6 A, 250 Vac
Stop relays maximum inductive load	2 A, 250 Vac
Number of relays	10, potential free ⁽¹⁾ , 10 A, 250 Vac
Input power	48...230 Vac
Digital inputs	0
Radio communication	Simplex
Maximum number of registered transmitters	8
Dimensions	120 x 117 x 51 mm (4.7 x 4.6 x 2 in)
Weight	400 g (0.8 lbs)
Operating temperature	-20...55 °C (-4...130 °F)
Frequency band	2405...2480 MHz
Number of channels	16 (channel 11...26) ⁽²⁾
Antenna	Internal antenna
Degree of protection	IP66

(1) Potential free means that a supply voltage is needed to get voltage out of relay.

(2) To know what is the radio frequency channel on your system, refer to the indicate radio frequency channel procedure (see page 6/8)

NOTE: When the equipment controlled by the standard relays of the Receiver is connected via the stop relays, make sure that the maximum current through the stop relays is still within the specification.

Transmitter Battery Charge

NOTE: Two different battery types are available for use in the transmitter. The transmitter is supplied with ZARC704 battery type and 3 x AAA alkaline batteries.

	ZARC702	ZARC704
Type of battery	Lithium-ion battery: replaceable, rechargeable	Replaceable battery pack for 3 x 1.5 V AAA / LR03 batteries
Operating time	Approximately 150 h.	Approximately 100 h. with alkaline
Charge	Charge in the charger device ZARC703	Do not charge in a charger device. Replace the batteries inside the battery pack.
Charging temperature	0...45 °C (32...113 °F)	Not applicable

NOTE: When approximately 10% of battery capacity remains, the top LED lights red.

⚠ WARNING**BATTERY LIFESPAN, RISK OF EXPLOSION AND FIRE**

Do not charge battery pack ZARC704 in the charger device ZARC703 or in any other charger.

Failure to follow these instructions can result in death, serious injury, or equipment damage.

Functional safety

The safety-related stop function in the radio system complies with EN ISO 13849-1 Category 3 PL d with the following values:

Safety function	MTTFd	DCavg	Category	Achievedd PL
Stop function	100 years	95 %	3	d

Note: The stops relays on the receiver unit must be correctly installed on the end-user system to ensure that opened/deactivated stop relays interrupt the power to the safety-related application. The safety level of the stop function can only be accredited when used in a complete end-user system which complies with EN ISO 13849-1:2008 Category 3 PL d.

Note: It is recommended that the functionality of the STOP button being tested at a regular basis: At minimum, when used for 200 hours. Test the stop pushbutton by pressing it and pulling it out

System configuration

The default configuration of the receiver unit complies with the appointed safety requirements. Any reconfiguration that breaches the safety requirements are indicated by a LED on the main board of the receiver. Before commissioning the radio system, the installer must check the LED indication.

Function LED	Status	indicates
PLD status LED (red)	ON	Not compliant with PLD
	OFF	Compliant with PLD

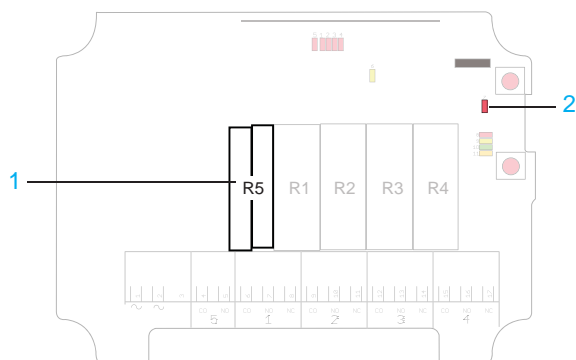

Part	Description
1	Stop relays
2	PLD status LED

NOTE: All safety-related parameters must be configured as follows to comply with the appointed safety requirements:

- The system must be configured in continuous radio mode
- All relays must be switched off when the radio link is down

Wiring

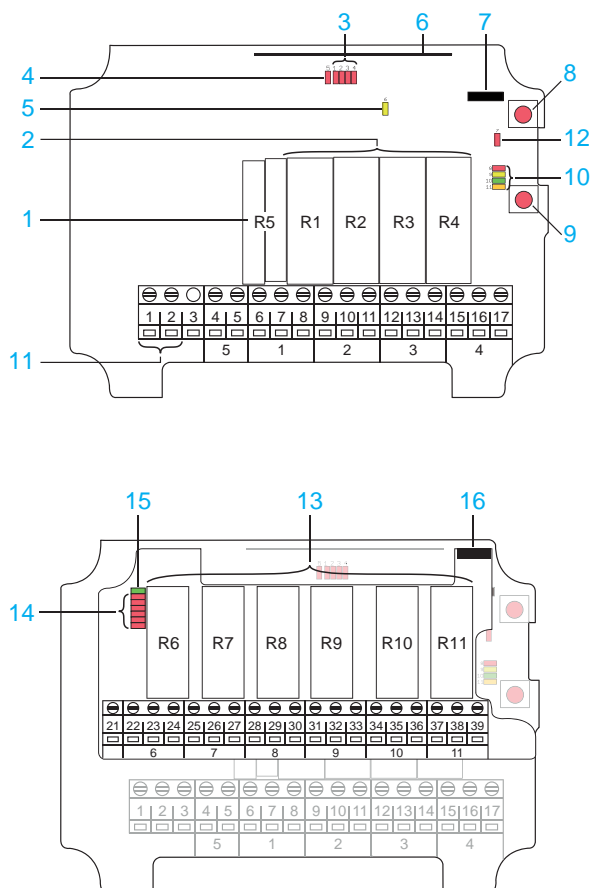

⚠ WARNING

UNINTENDED EQUIPMENT OPERATION

- Use shielded cables wherever specified for inputs and outputs connections.
- Properly ground the cable shields as indicated in the related documentation.
- Route I/O cables separately from power cables.

Failure to follow these instructions can result in death, serious injury, or equipment damage.

⚠ WARNING

UNINTENDED EQUIPMENT OPERATION

Connect the receiver protective earth ground connection to the machine ground.

Failure to follow these instructions can result in death, serious injury, or equipment damage.

Part	Description
1	Stop relays
2	Relays R1...R4
3	Relays LEDs (red)
4	Stop relay LED (red)
5	Power LED (yellow)
6	Radio module
7	Programming connector
8	Function button (cancel)
9	Select button (OK)
10	Function LEDs (8 = red, 9 = yellow, 10 = green, 11 = orange)
11	Terminal block for input power
12	PLD status LED
13	Relays R6...R11
14	Relays LEDs (red)
15	Communication LED (green)
16	Programming connector

Example of wiring diagram for hoisting application:

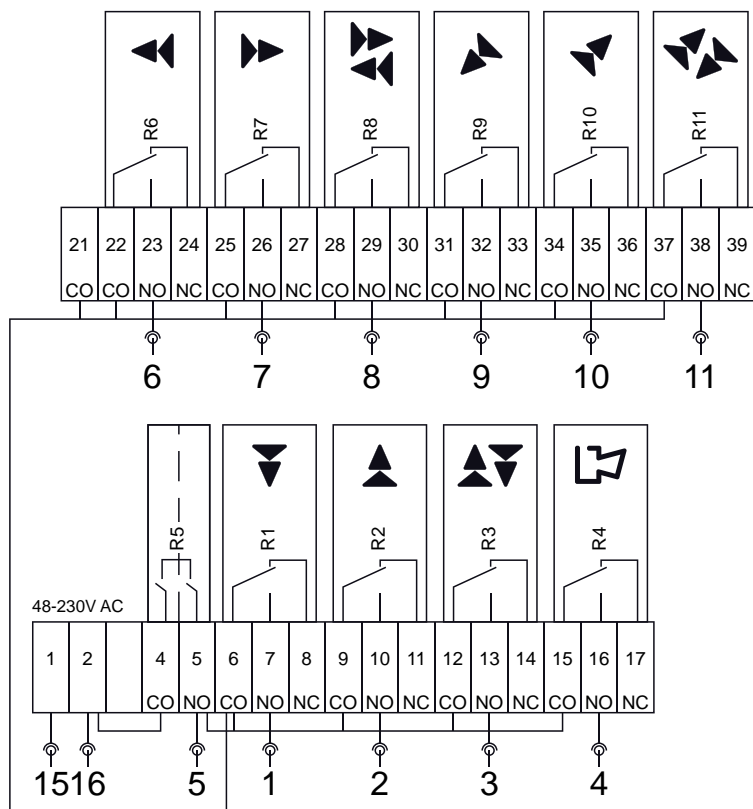

Signal	ZARB10WS. Pin nb.	ZARB10WS. Cable no.
Power supply	1	15
Power supply	2	16
Not connected	3	-
Stop relay R5	Common	4
	Output (NO type)	5
Relay R1	Common	6
	Output (NO type)	7
	Output (NC type)	8
Relay R2	Common	9
	Output (NO type)	10
	Output (NC type)	11
Relay R3	Common	12
	Output (NO type)	13
	Output (NC type)	14
Relay R4	Common	15
	Output (NO type)	16
	Output (NC type)	17
Common		21
Relay R6	Common	22
	Output (NO type)	23
	Output (NC type)	24
Relay R7	Common	25
	Output (NO type)	26
	Output (NC type)	27
Relay R8	Common	28
	Output (NO type)	29
	Output (NC type)	30
Relay R9	Common	31
	Output (NO type)	32
	Output (NC type)	33
Relay R10	Common	34
	Output (NO type)	35
	Output (NC type)	36
Relay R11	Common	37
	Output (NO type)	38
	Output (NC type)	39

Diagnostic

Function LEDs

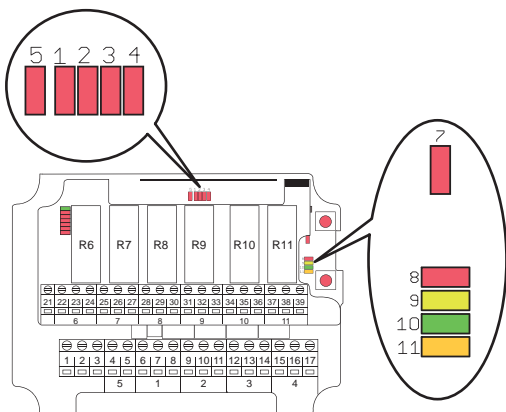

LED	Color	OFF	ON	Indicates
7	Red		X	Not compliant with PLd.
		X		Compliant with PLd.
8	Red	X		No Transmitter is registered.
			X	Flashes once: One or more Transmitters are registered. No radio transmission established.
			X	Double flash: One or more Transmitters are registered and paired in. No radio transmission established.
		X		Radio transmission established.
9	Yellow		X	Receiving a radio packet from a Transmitter other than an eXlhoist.
9	Yellow		X	Receiving a radio packet from a Transmitter set to the radio mode different from that of a Receiver.
10	Green		X	
9	Yellow		X	Receiving a radio packet from a Transmitter that is not registered.
11	Orange		X	
10	Green		X	Receiving a radio packet, low signal (RSSI).
11	Orange		X	Receiving a radio packet, configuration ID not accepted.
10	Green		X	Receiving a radio packet, custom ID not accepted.
11	Orange		X	
9	Yellow		X	1. Receiving a radio packet from a registered Transmitter. The Receiver is already controlled by another registered Transmitter. NOTE: "Radio link" must be activated in the Receiver. 2. Load select mode is activated. Incorrect Load is selected on the Transmitter.
10	Green		X	
11	Orange		X	

1...5 Relay LEDs
7...11 Function LEDs

If an error occurs, all Function LEDs flash as well as one or more Relay LEDs light up. Take note of the Relay LEDs that light up and contact your Schneider Electric representative for assistance.

Main procedures for use

Note: to establish a radio link between the transmitter and the receiver, both devices must be set to the same radio mode.

⚠ ⚠ DANGER

HAZARD OF ELECTRIC SHOCK

The settings of the transmitter into the receiver must respect the following step by step procedure:

- Verify the voltage is OFF before removing the cover of the receiver.
- Remove the cover.
- Power ON the product to register or erase the transmitter(s) from the receiver.
- Do not touch components or terminals with voltage present
- Use your fingers only to press the 2 red buttons
- Power OFF the product after the configuration is applied.
- Close the cover.

Failure to follow these instructions will result in death or serious injury.

⚠ WARNING

UNINTENDED EQUIPMENT OPERATION

Only keep the transmitters that you intend to use registered in the receivers.

Failure to follow these instructions can result in death, serious injury, or equipment damage.

Register the transmitter in the receiver

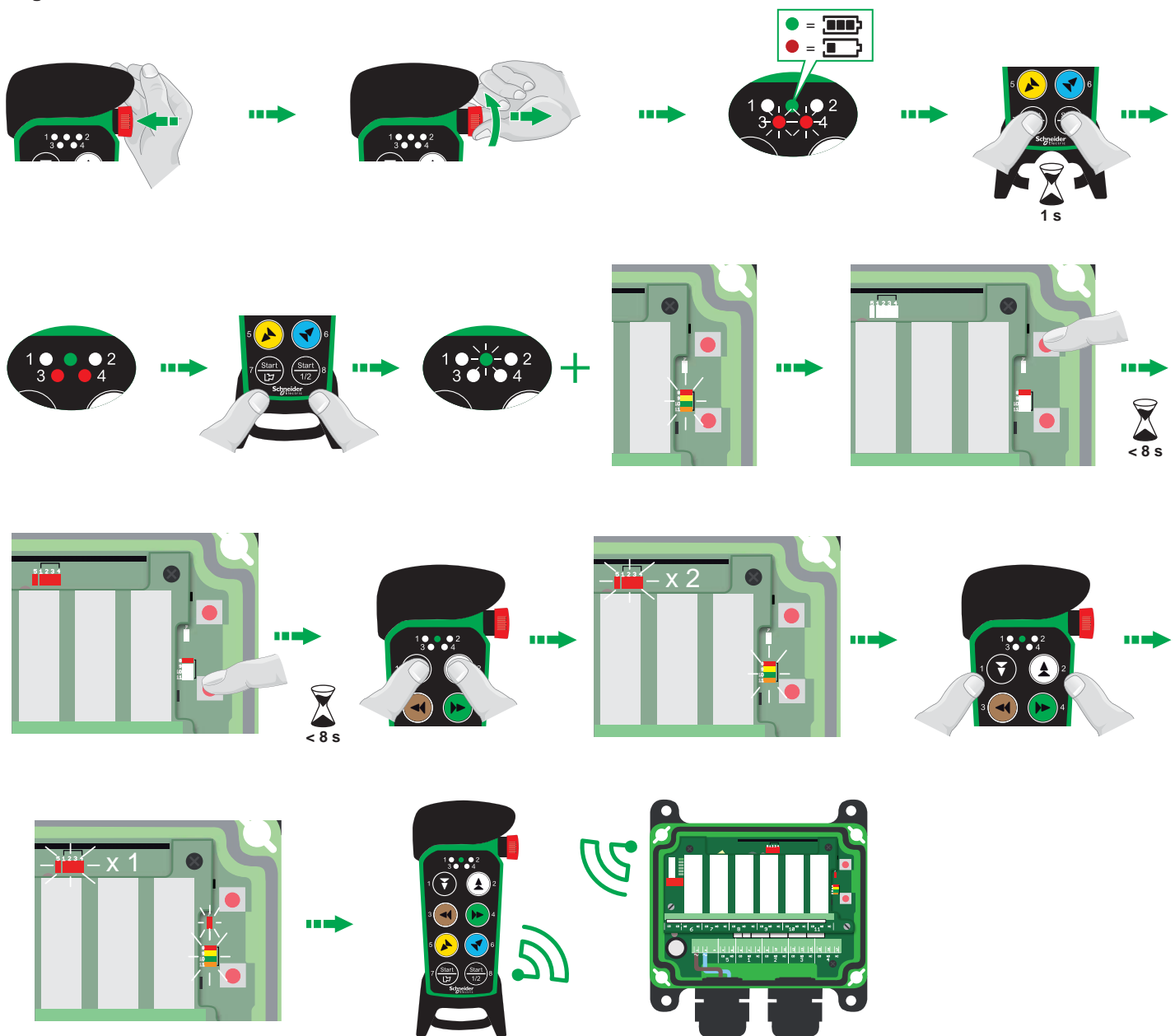

Indicate radio frequency channel

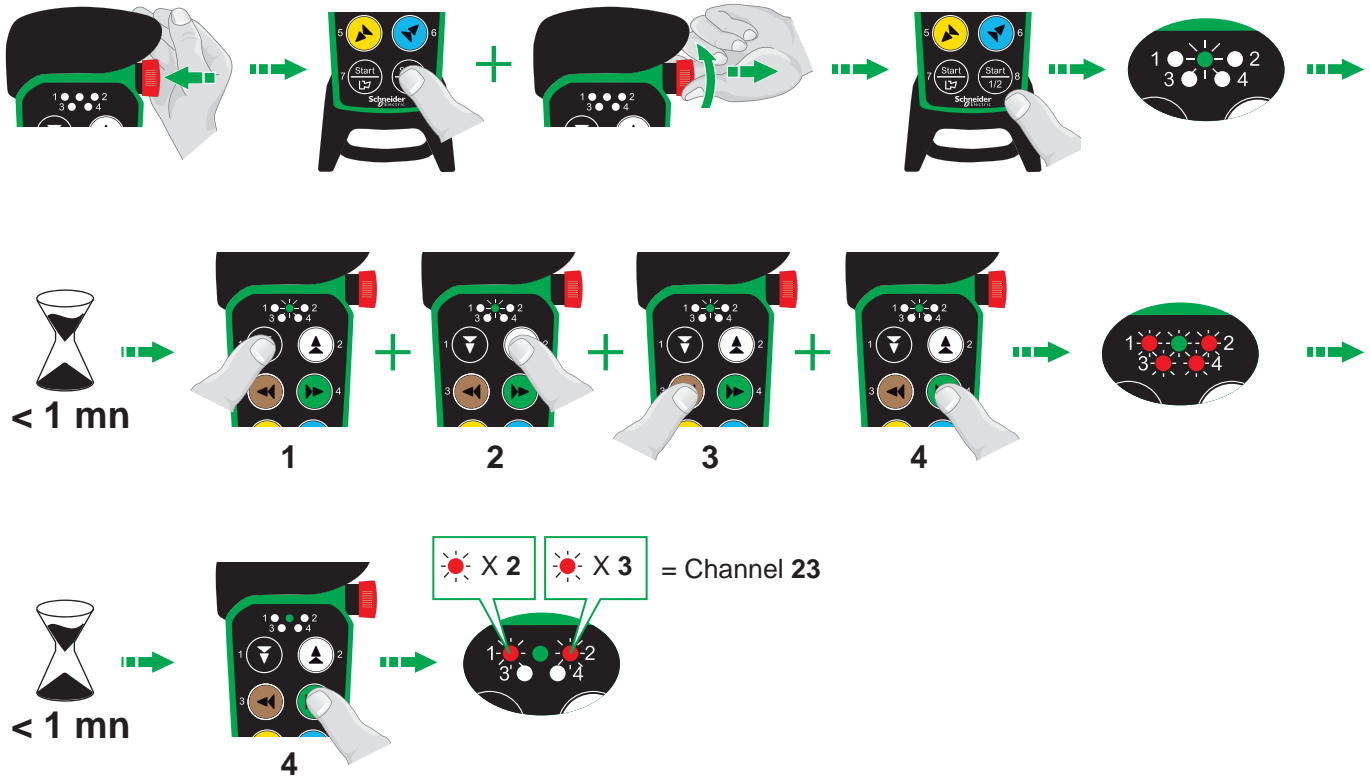

Quick unpairing

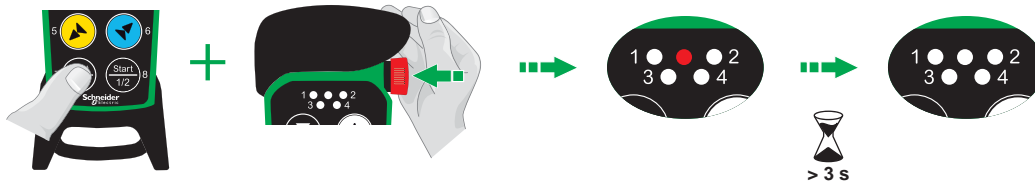

NOTE: Quick unpairing can only be performed when the transmitter is **ON** and the radio link is **UP**. The quick unpairing procedure unpairs the transmitter from all receivers that are part of the radio session.

Unpairing from menu mode

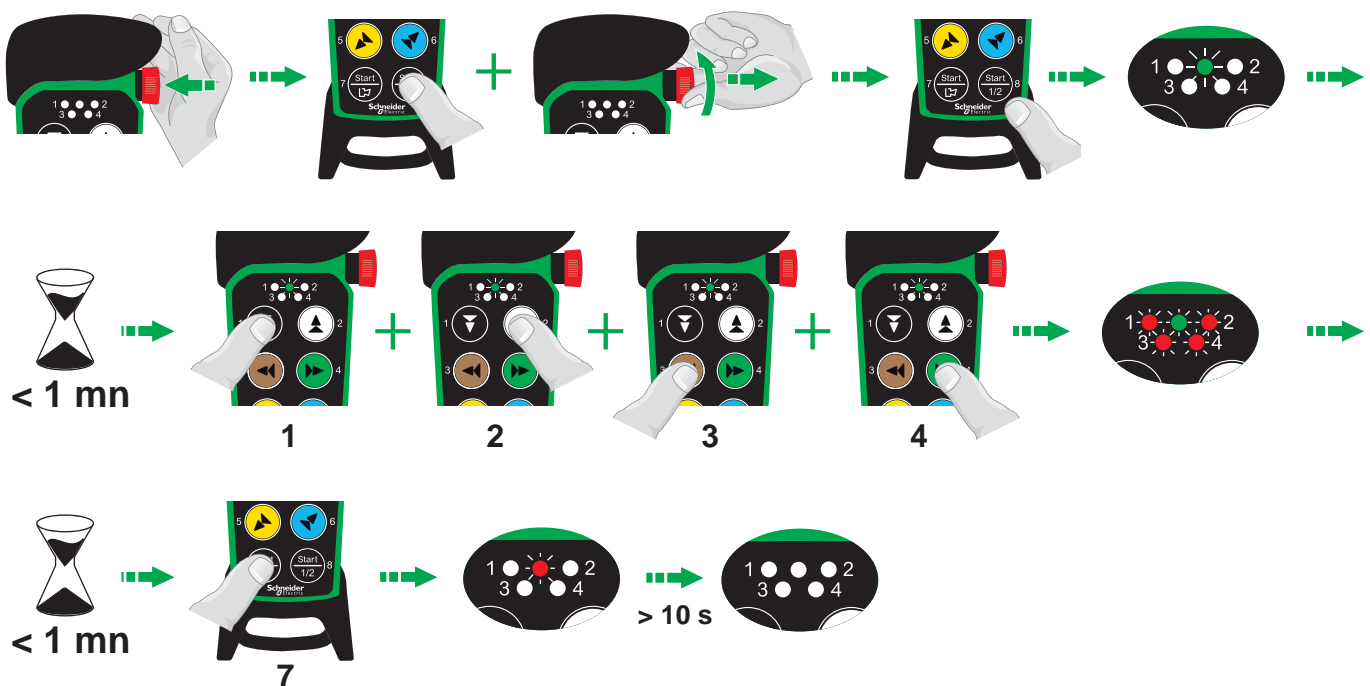

NOTE: This unpairing procedure can be used when the button 7 (used for quick unpairing) is used by another function.

Accessories

ZARC701: Multi charger power supply (6 W) 5 Vdc / 1.2 A

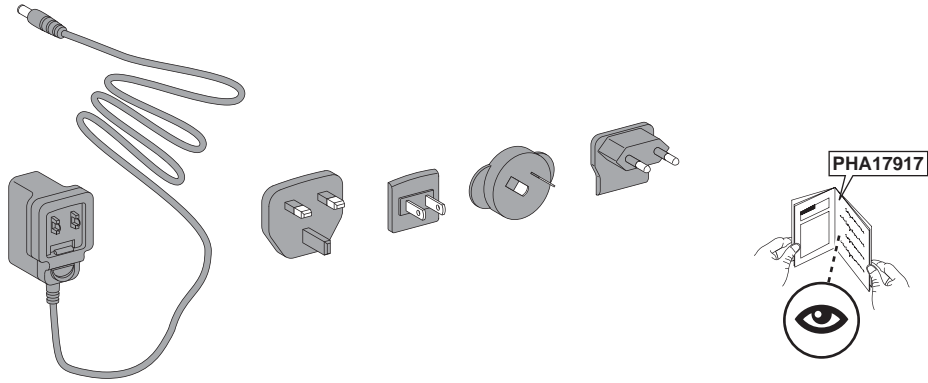

ZARC702: Battery Table Charger 5 V + Li-Ion Rechargeable battery

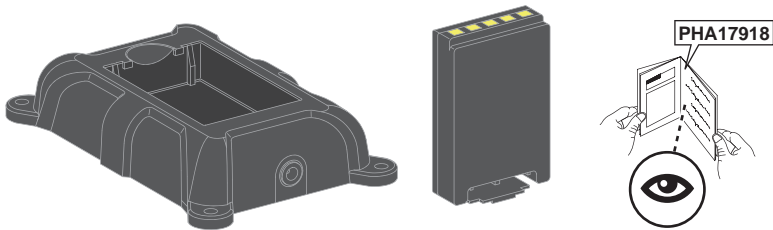

ZARC703: Battery Table Charger 5 V

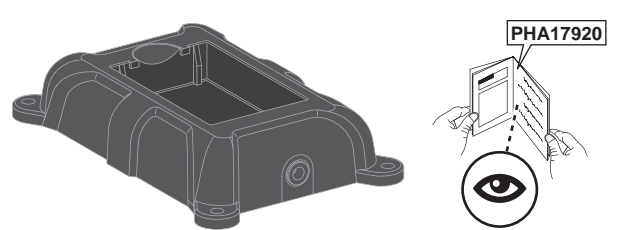

ZARC704: Battery pack for 3xAAA (not included)

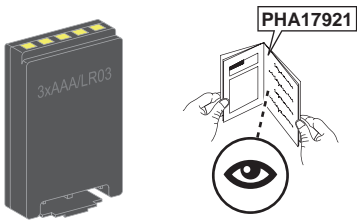

ZARC705: Pushbuttons front cover

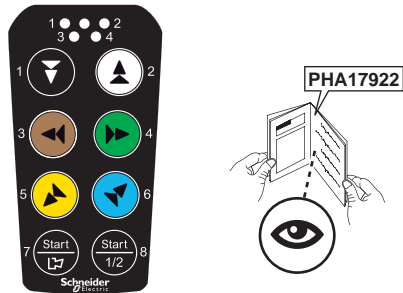

ZARC706: Rubber protection cover

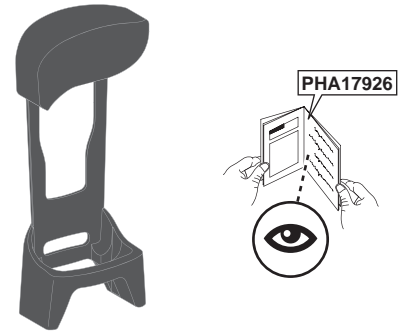

ZARC707: Transmitter hanging belt

