

WIRING DIAGRAM

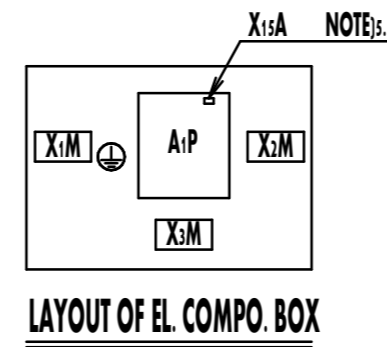

NOTES:

1. THIS WIRING DIAGRAM IS FOR BS UNIT ONLY.
2. THE MARKS IN THIS DIAGRAM INDICATE:
 : TERMINAL BLOCK, : CONNECTOR, : FIELD WIRING, ⊕ : EARTH TERMINAL.
3. FOR WIRING FOR THE TERMINAL BLOCK X2M, X3M (OPERATION), REFER TO THE INSTALLATION MANUAL ATTACHED TO THE PRODUCT.
4. THE FACTORY SETTING OF DIP SWITCH (DS1, DS2) ARE AS FOLLOWS. FOR THE SETTING METHOD OF DIP SWITCH (DS1, DS2), REFER TO "THE INSTALLATION MANUAL".

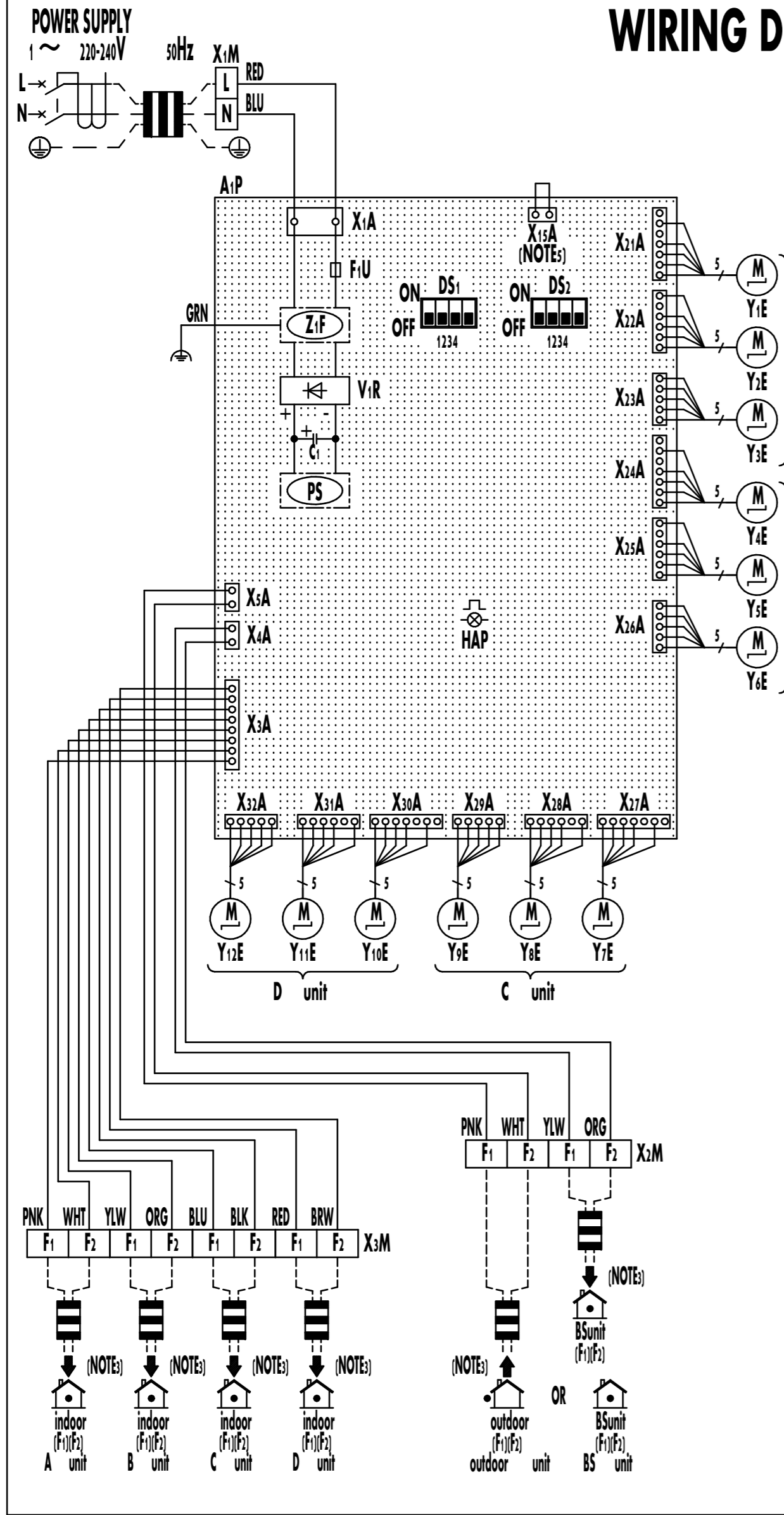
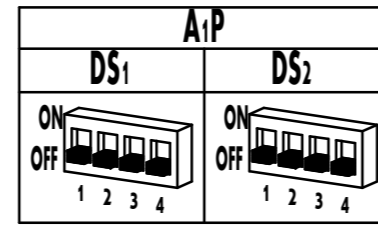

5. AS FOR X15A (A1P), REMOVE THE SHORT CIRCUIT CONNECTOR AND CONNECT THE AIR CONDITIONER STOP SIGNAL (OPTIONAL PRODUCT) WHEN USING THE DRAIN-UP KIT (OPTIONAL PRODUCT). FOR DETAILS, PLEASE REFER TO THE OPERATION MANUAL ATTACHED TO THE KIT.

A1P	PRINTED CIRCUIT BOARD (CONTROL)	
C1	CAPACITOR	
DS1, DS2	DIP SWITCH	
F1U	FUSE (T, 3.15A, 250V)	
HAP	FLASHING LAMP (SERVICE MONITOR-GREEN)	
PS	SWITCHING POWER SUPPLY	
V1R	DIODE BRIDGE	
X1M	TERMINAL STRIP (POWER)	
X2M, X3M	TERMINAL STRIP (TRANSMISSION)	
Z1F	NOISE FILTER	
Y1E	ELECTRIC EXPANSION VALVE (SUCTION)	A unit
Y2E	ELECTRIC EXPANSION VALVE (HP/LP GAS)	
Y3E	ELECTRIC EXPANSION VALVE (SUBCOOL)	
Y4E	ELECTRIC EXPANSION VALVE (SUCTION)	B unit
Y5E	ELECTRIC EXPANSION VALVE (HP/LP GAS)	
Y6E	ELECTRIC EXPANSION VALVE (SUBCOOL)	C unit
Y7E	ELECTRIC EXPANSION VALVE (SUCTION)	
Y8E	ELECTRIC EXPANSION VALVE (HP/LP GAS)	
Y9E	ELECTRIC EXPANSION VALVE (SUBCOOL)	D unit
Y10E	ELECTRIC EXPANSION VALVE (SUCTION)	
Y11E	ELECTRIC EXPANSION VALVE (HP/LP GAS)	
Y12E	ELECTRIC EXPANSION VALVE (SUBCOOL)	
OPTIONAL ACCESSORIES		
X15A	CONNECTOR (DRAIN-UP KIT ABNORMAL SIGNAL)	

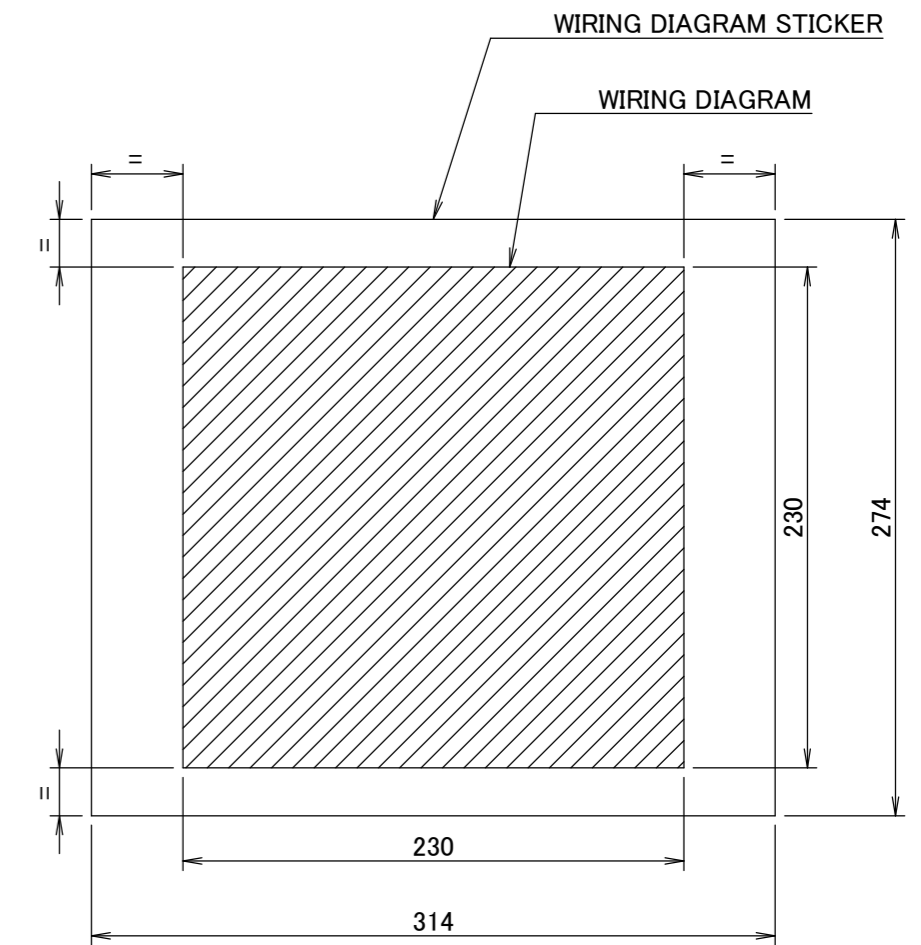

230

2D105405-1

230

NOTES:

1. LAYOUT AND LETTERSIZE = THIS DRAWING.
2. DO NOT PRINT DIMENSIONS.
3. PRINTING: OFFSET PRINTING BLACK.
4. SLITS: MAKE 2 OR 3 SLITS AT THE REAR SIDE.
5. PRINTING MUST COMPLY TO THE RUBBING TEST OF EN60335-2-40 CLAUSE 7. 14.