

POMPE RELEVAGE DE CONDENSAT EXTERIEURE 15L/H

UTILISATION :

• Constituée d'un bloc pompe et d'un système de détection indépendant ou intégré, une pompe de relevage permet, en l'absence de pente (écoulement gravitaire), d'évacuer l'eau de condensation vers une tuyauterie d'eaux usées.

DESCRIPTION :

• Référence : AP12

L'AP12 est la pompe extérieure par excellence ! Design, silencieuse, avec Alarme 5Amp résistifs NO-NF, facile à entretenir, l'AP12 permet de relever les eaux des condensats des appareils jusqu'à 10kW soit 35 000 BTU ! Fini les difficultés d'installation et d'entretien dans des unités intérieures de plus en plus inaccessibles !
Sur conditionnement : Boite de 10

CARACTERISTIQUES :

- Débit : 15 litres/heure à 0 mètre
- Avec Alarme 5 Amp résistifs NO-NF
- Niveau sonore < 21 dBA à 1m
- Hauteur aspi max : 2 m
- Hauteur refoul. max : 10 m
- Tension : 220-240 v
- Fréquence : 50-60 Hz
- Puissance : 19 w
- Dimension hauteur : 55 mm
- Dimension largeur : 230 mm
- Dimension profondeur : 62 mm
- Réversible coté dte/gauche : oui
- Réversible dessous dte/gauche : oui
- Livré préassemblée : oui
- Fixations et visseries fournies

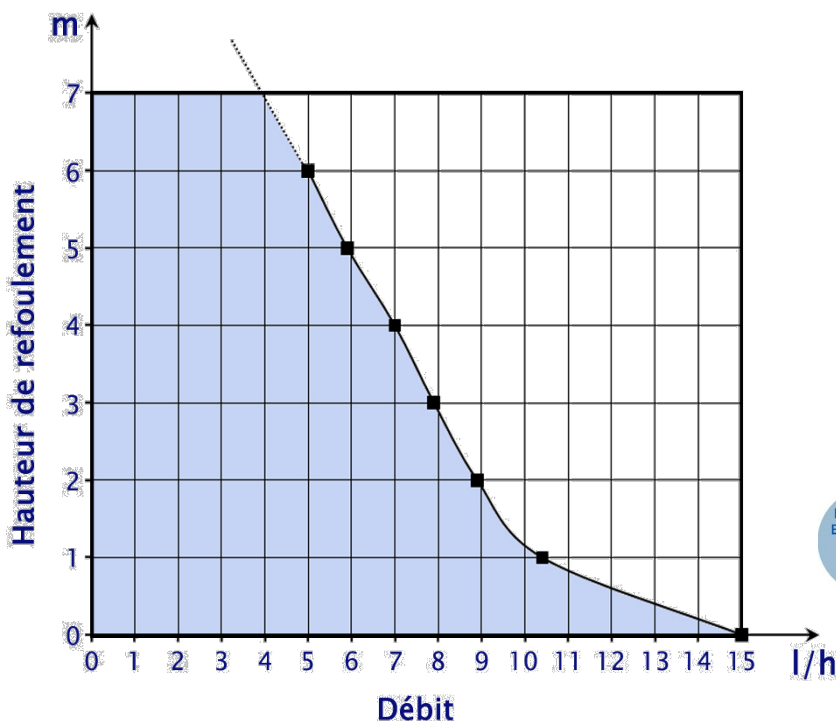
Positionnable
EN DESSOUS
ou
SUR LE
CÔTÉTaille
recordDesign
discretBac
démontableFiltre
intégré
démontable

SICCOM
FLOWATCH® VISION
DE05LCB900

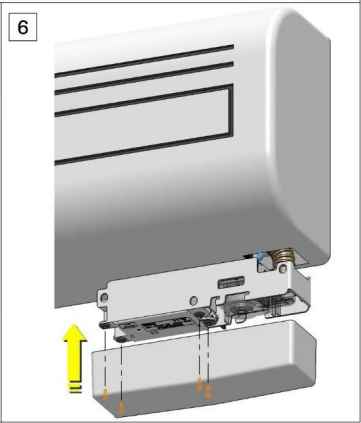
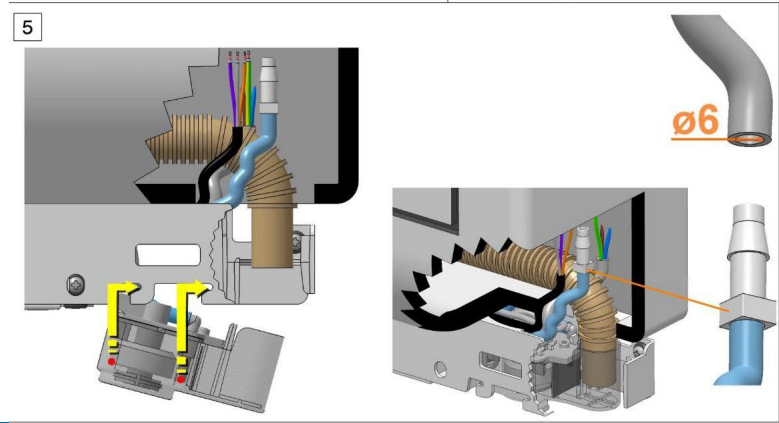
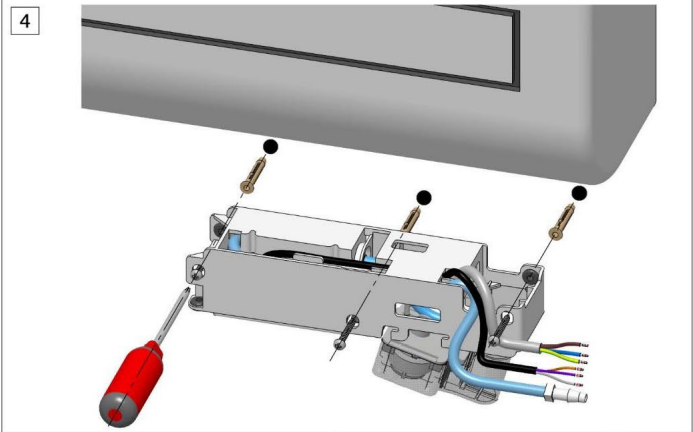
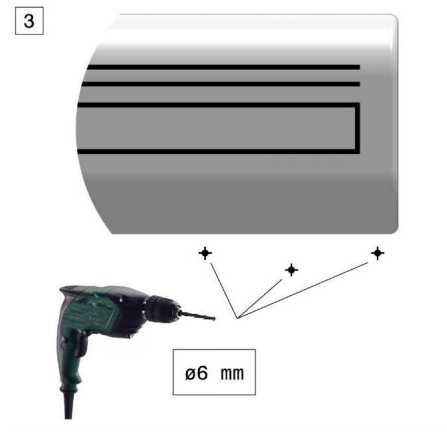
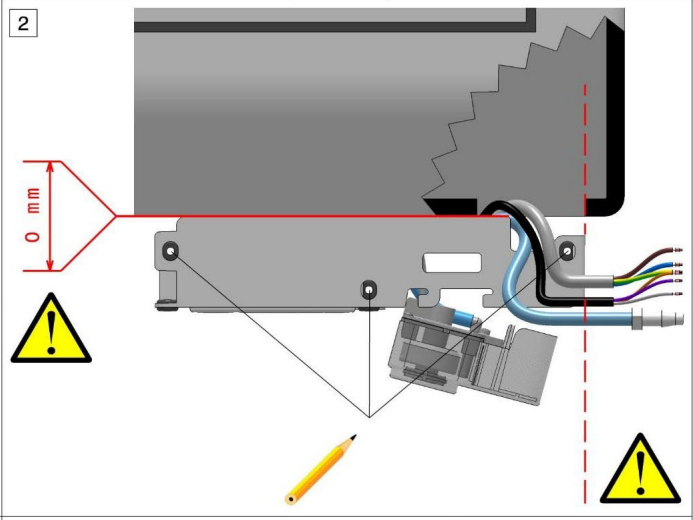
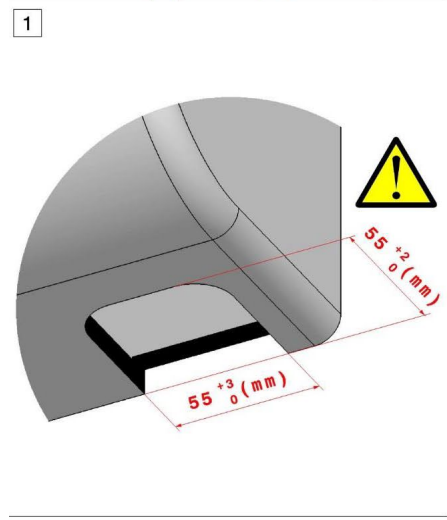
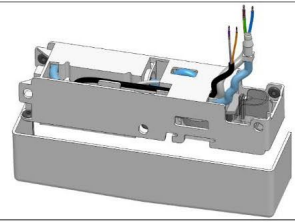
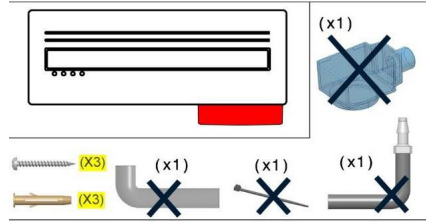

INSTRUCTION DE MONTAGE



Concepteur et fabricant de liaisons frigorifiques et accessoires de climatisation

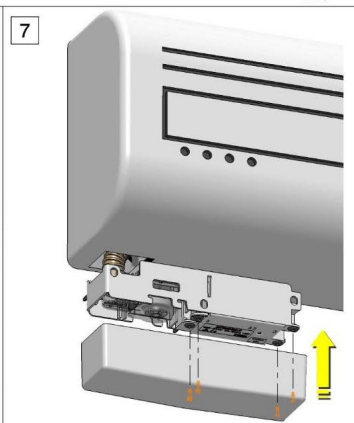
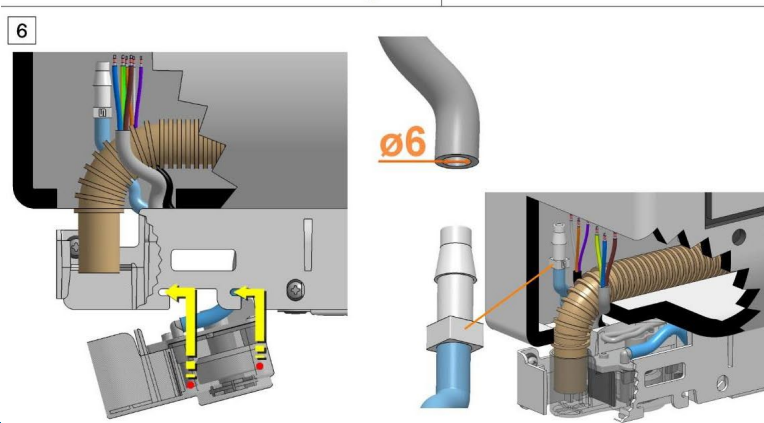
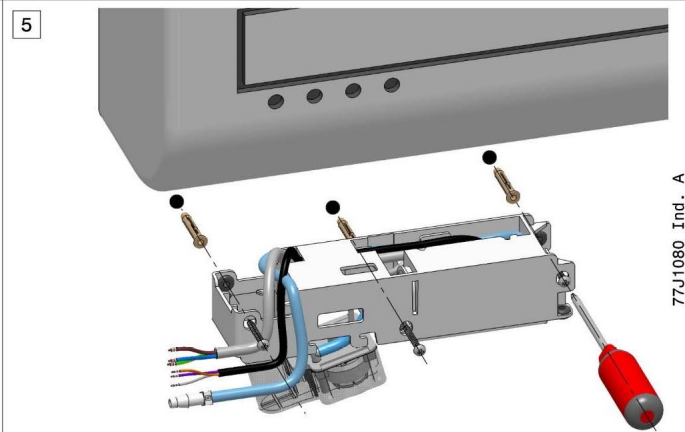
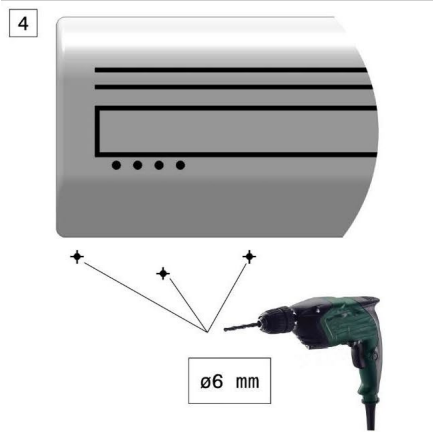
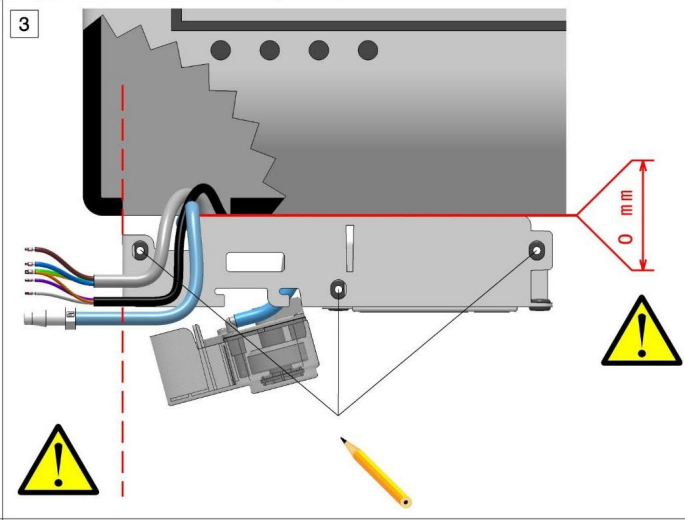
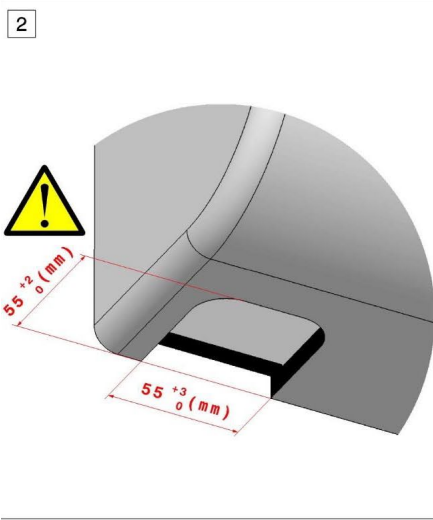
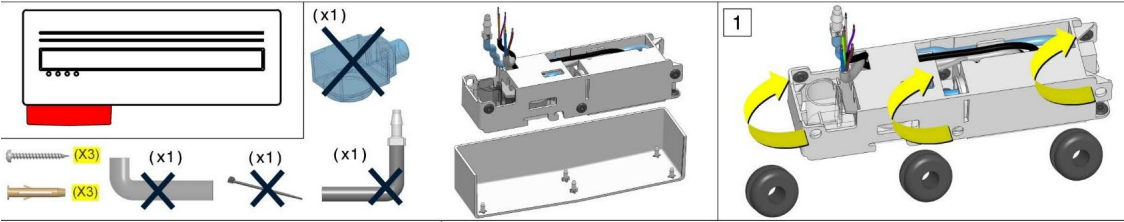

siccom
FLOWATCH® VISION
DE05LCB900

