

## Table of Contents

<b>Hazardous Locations</b> .....	2	<b>Dimensions</b> .....	9
<b>Safety Information</b> .....	3	<b>Schematics</b> .....	10, 11
<b>Informations relatives à la sécurité</b> .....	4	3-Phase Delta, 3-Phase Wye .....	10
<b>System Configuration</b> .....	5, 6	Single Phase .....	10
Components .....	5	DC .....	11
Part Number Identification .....	5	<b>Installation Considerations</b> .....	12
Power for AVT Test .....	5	General Information .....	12
DC Power Input .....	5	Effect on SCCR .....	12
Indicator Module .....	6	Use of Overcurrent Protection .....	12
Absence of Voltage Outputs .....	6	<b>Installation Instructions</b> .....	13, 14
<b>Technical Specifications</b> .....	7, 8	<b>Commissioning Checklist</b> .....	15
Environmental Ratings, Applications .....	7	<b>Operating Instructions</b> .....	16
AVT Power Requirements .....	7	<b>Troubleshooting</b> .....	17
AVT Quiescent Current, Voltage Illumination Level .....	7	<b>Maintenance</b> .....	18, 19
Functional Safety .....	8	<b>Warranty</b> .....	20
Standards and Certifications .....	8		

The VeriSafe™ 2.0 Absence of Voltage Tester (AVT) is a permanently-mounted tester that is used to verify a circuit is de-energized prior to opening an electrical enclosure. Once installed, a push of a button enables personnel who have been trained on the operation of the tester to verify the absence of voltage and see an active indication when the absence of voltage is confirmed.

**The VeriSafe™ 2.0 AVT safety function tests for absence of voltage. When the voltage is verified below 3VAC and 3VDC, the green absence of voltage indicator illuminates and the external outputs activate for 5 seconds.**



### TO REDUCE THE RISK OF INJURY, USER MUST READ INSTRUCTION MANUAL

**NOTE:** In the interest of higher quality and value, Panduit™ products are continually being improved and updated. Consequently, pictures may vary from the enclosed product.

**NOTE:** Updates to this Instruction Manual may be available. Check [www.panduit.com](http://www.panduit.com) for the latest version of this manual.

### Tech Support

#### North America Tech Support:

techsupport@panduit.com  
Tel: 866.405.6654

#### EU Tech Support :

techsupportemea@panduit.com  
Tel: 31.546.580.452  
Fax: 31.546.580.441

#### Asia Pacific Tech Support:

techsupportap@panduit.com  
Tel:  
Singapore: 1-800-Panduit (7263848)  
Australia: 1-800-Panduit (7263848)  
Korea: 02.21827300

For a copy of Panduit product warranties, log on to [www.panduit.com/warranty](http://www.panduit.com/warranty)

For more information

Visit us at [www.panduit.com/verisafe](http://www.panduit.com/verisafe)

1002985, B21110\_EN\_rev4

# Hazardous Locations

Hazardous Locations	
<b>Special Conditions of Use</b> 	<ul style="list-style-type: none"> <li>■ The equipment shall be installed in an enclosure that provides a degree of protection not less than IP 54 in accordance with IEC 60079-0.</li> <li>■ The open-type device shall be installed through an EPL Dc end-equipment enclosure for the applicable dust group, temperature classification and ambient temperature range.</li> <li>■ Ambient temperature range: <math>-25^{\circ}\text{C} \leq T_{\text{amb}} \leq 60^{\circ}\text{C}</math></li> <li>■ The enclosure must only be accessible with use of a tool.</li> <li>■ To minimize the risk of electrostatic discharge, only clean with a damp cloth.</li> <li>■ WARNING – CHANGE BATTERY OR REMOVE CAP ONLY WHEN AREA IS NON-HAZARDOUS.</li> <li>■ Use conductors suitable for at least <math>85^{\circ}\text{C}</math>.</li> </ul>
Isolation Module (Hazardous Location Ratings)	cULus: Class I, Division 2, Groups A, B, C, D Class I Zone 2 AEx ec IIC T5 Gc; Ex ec IIC T5 Gc
Voltage Indicator Modules (Hazardous Location Ratings)	cULus: Class I, Division 2, Groups A, B, C, D Class II, Division 2, Groups F and G Class I Zone 2 AEx ic ec IIC T6 Gc; Ex ic ec IIC T6 Gc Zone 22 AEx tc IIIC T68°C Dc; Ex tc IIIC T68°C Dc*

## ENDROITS DANGEREUX

Endroits dangereux	
<b>Conditions particulières d'utilisation</b> 	<ul style="list-style-type: none"> <li>■ L'équipement doit être installé dans une enveloppe offrant au moins la protection IP54, conformément à la norme IEC 60079-0.</li> <li>■ Le dispositif de type ouvert doit être installé à travers une enveloppe faite d'un matériel d'extrémité dont le niveau de protection de matériel est EPL Dc et qui est conforme au groupe de matériels pour poussières, au classement en température et à la plage de température ambiante applicables.</li> <li>■ Plage de température ambiante : <math>-25^{\circ}\text{C} \leq T_{\text{amb}} \leq 60^{\circ}\text{C}</math></li> <li>■ L'enveloppe doit être accessible uniquement à l'aide d'un outil.</li> <li>■ Pour réduire au minimum le risque de décharge électrostatique, nettoyer uniquement avec un chiffon humide.</li> <li>■ AVERTISSEMENT : REMPLACER LA PILE OU RETIRER LE CAPUCHON UNIQUEMENT LORSQUE LA ZONE EST SANS DANGER.</li> <li>■ Utiliser des conducteurs adaptés à une température d'au moins <math>85^{\circ}\text{C}</math>.</li> </ul>
Module d'isolement (caractéristiques nominales pour les endroits dangereux)	cULus : Classe I, division 2, groupes A, B, C et D Classe I, zone 2, AEx ec IIC T5 Gc; Ex ec IIC T5 Gc
Modules d'indication de tension (caractéristiques nominales pour les endroits dangereux)	cULus : Classe I, division 2, groupes A, B, C et D Classe II, division 2, groupes F et G Classe I, zone 2, AEx ic ec IIC T6 Gc; Ex ic ec IIC T6 Gc Zone 22, AEx tc IIIC T68°C Dc; Ex tc IIIC T68°C Dc*

# Safety Information

This manual contains information and warnings which must be followed to ensure safe operation of the AVT. If the AVT is not used as described in this manual, the safety features of the AVT might be impaired. **Failure to comply with the warnings and information in this manual could result in product failure, electrical shock, severe injury or death.**

## Special Conditions of Use



## Hazardous Locations

■ Refer to Page 2 of this manual for all Special Conditions of Use for Hazardous Locations.

### WARNING:



- Always de-energize power before accessing an electrical enclosure.
- Always follow safety and lockout/tagout procedures when working on or near electrical systems and equipment.
- Use of the AVT does not replace lockout/tagout procedures. The AVT is intended to be used in conjunction with lockout/tagout processes and only addresses the Absence of Voltage verification step.
- Use proper personal protective equipment (PPE) when working around sources of hazardous electrical energy.
- Do not use this product outside of the specified performance and environmental limits.
- This product must be installed and commissioned by a qualified electrical worker familiar with local and national electrical codes.
- The AVT will only test for absence of voltage at the point in the circuit where it is installed. If there are other sources of power in the equipment, dangerous voltage may be present.
- Lack of red voltage presence indicators alone does not verify the absence of voltage, the Absence of Voltage test must be initiated followed by the illumination only of the green indicator to verify the absence of voltage.
- The AVT must be installed correctly and grounded as described in this Instruction Manual to provide proper indication of absence of voltage. Sensor leads must not be mechanically connected with each other for the device to verify connection to the circuit. Correct function of the device must be verified after installation, see Commissioning Checklist section, p. 15
- Excess length from sensor leads should be trimmed. Sensor leads should not be extended with a splice. When using terminal or power distribution blocks, the total length of the sensor leads from the isolation module to the source conductors shall not exceed 10 feet (3.0m).
- Sensor leads of the same label designation should be terminated on the same conductor (L1, L2, L3, GND). Each conductor should have at least one sensor lead set, as shown on the schematic diagrams.
- Always comply with local installation codes and standards.
- The battery powered indicator module contains a lithium battery that is a fire, explosion and severe burn hazard. Do not crush, recharge, disassemble or heat above 85°C (185°F), incinerate, or expose contents to water.
- The AVT will not work with a standard alkaline 1.5 V AA battery. Use only Panduit approved battery.
- Use only 2.0 AVT system components (system cable, isolation module, indicator module). Do not use a standard Ethernet cable. Do not use 1.0 AVT system components with 2.0 AVT system components.
- Battery, system cable, o-rings and gaskets can be replaced. No other part of the product is serviceable. Do not attempt to open the indicator module or isolation module for repair or modification. When servicing this product, only use specified replacement parts.
- The section of the indicator module that is external to the electrical enclosure is approved for wash down when installed in an appropriate enclosure. Before a wash down operation, ensure the o-rings are in good condition, the faceplate is undamaged and fully secured to the unit and the cap is fully installed.
- The AVT system cable must be separated from the sensor leads and other circuits in the electrical enclosure by a minimum of 0.25 inches (6 mm).
- To prevent damage to the AVT in high-vibration installations, surface mount the isolation module using screws and secure the sensor lead wires and AVT system cable to prevent strain on the connection points.
- Ensure all sensor leads are terminated properly and secured to the power conductor or other nearby rigid feature to prevent movement if the termination fails to remain intact.
- The VeriSafe 2.0 AVT is designed for use in 50 or 60Hz AC electrical systems and DC electrical systems. The AVT should not be installed on sections of a circuit where the AVT is exposed to high frequency energy such as variable frequency drives (VFD) or other circuit elements generating high frequency energy (waveforms exhibiting high Electro-Magnetic Interference (EMI)). For more information on where to position the VeriSafe 2.0 AVT in VFD applications, see the Technical Note available on Panduit.com.

Should a problem occur during installation, operation or maintenance of the VeriSafe 2.0 AVT, contact Panduit technical support. Contact Panduit if you have any product problems related to the safety function of the product. The product model number and serial number are printed on the isolation module and indicator module labels.



VeriSafe 2.0 AVT is a product containing electronic circuit boards in both the indicator and isolation modules. The indicator module contains a lithium battery. When decommissioning, remove the battery. Do not discard the battery in the trash; take it to an appropriate battery recycling facility. The indicator and isolation modules can be disposed of at an electronics recycling facility.

# INFORMATIONS RELATIVES À LA SÉCURITÉ

Le présent manuel contient des renseignements et des avertissements qui doivent être suivis pour assurer un fonctionnement en toute sécurité du VAT. Si le VAT n'est pas utilisé comme décrit dans le présent manuel, ses fonctions de sécurité pourraient être altérées.

**Le non-respect des renseignements et des avertissements contenus dans le présent manuel pourrait entraîner une défaillance du produit, des décharges électriques, des blessures graves ou même la mort.**

Conditions particulières d'utilisation



Endroits dangereux

- Se reporter à la page 2 du présent manuel pour toutes les conditions spéciales d'utilisation des emplacements dangereux.

## AVERTISSEMENTS



- Toujours éteindre l'alimentation électrique avant d'accéder à une enveloppe électrique.
- Toujours suivre les procédures de sécurité, de verrouillage et d'étiquetage pour exécuter des travaux sur des systèmes et des équipements électriques ou à proximité de tels dispositifs.
- L'utilisation du VAT ne remplace pas les procédures de verrouillage et d'étiquetage. Le VAT est conçu pour être utilisé conjointement avec les processus de verrouillage et d'étiquetage; il remplace uniquement l'étape de vérification d'absence de tension.
- Utiliser un équipement de protection individuelle approprié lors de travaux à proximité de sources d'énergie électrique dangereuses.
- Ne pas utiliser ce produit en dehors des limites de performance et des limites environnementales spécifiées.
- Ce produit doit être installé et mis en service par un électricien qualifié connaissant les codes électriques locaux et nationaux.
- Le VAT ne vérifiera l'absence de tension qu'au point du circuit où il est installé. S'il existe d'autres sources d'alimentation dans l'équipement, une tension dangereuse peut être présente.
- L'absence des indicateurs rouges de présence de tension ne permet pas à elle seule de vérifier l'absence de tension. Pour ce faire, il faut amorcer la vérification d'absence de tension et seul l'indicateur vert doit s'allumer.
- Le VAT doit être correctement installé et mis à la terre comme décrit dans le présent manuel pour fournir une indication appropriée de l'absence de tension. Pour que l'appareil vérifie la connexion au circuit, les fils de détection ne doivent pas être connectés mécaniquement entre eux. Le bon fonctionnement de l'appareil doit être vérifié après son installation (voir la Liste de vérification de mise en service à la page 15).
- L'excédent des fils de détection doit être coupé et ceux-ci ne doivent pas être prolongés à l'aide d'une épissure. Lors de l'utilisation de borniers ou de blocs de distribution d'énergie, la longueur totale des fils de détection entre le module d'isolement et les conducteurs de la source ne doit pas dépasser 3,0 m (10 pi).
- Les fils de détection ayant la même désignation sur l'étiquette doivent être raccordés au même conducteur (L1, L2, L3 ou TERRE). Chaque conducteur doit compter au moins un ensemble de fils de détection, comme indiqué sur les schémas.
- Toujours respecter les normes et les codes d'installation locaux.
- Le module d'indication alimenté par pile contient une pile au lithium qui présente un risque d'incendie, d'explosion et de brûlures graves. Ne pas écraser, recharger, démonter, incinérer ou chauffer la pile à plus de 85 °C (185 °F), ni exposer son contenu à l'eau.
- Le VAT ne fonctionne pas avec une pile alcaline AA standard de 1,5 V. Utiliser uniquement des piles approuvées par Panduit.
- Utiliser uniquement les composants du système VAT 2.0 (câble système, module d'isolement, module d'indication). Ne pas utiliser un câble Ethernet standard. Ne pas utiliser les composants du système VAT 1.0 avec ceux du système VAT 2.0.
- La pile, le câble système, les joints toriques et les joints d'étanchéité peuvent être remplacés. Aucune autre pièce du produit ne peut être remplacée. Ne pas essayer d'ouvrir le module d'indication ou le module d'isolement à des fins de réparation ou de modification. Lors de l'entretien de ce produit, utiliser uniquement les pièces de rechange spécifiées.
- La partie du module d'indication qui se trouve à l'extérieur de l'enveloppe électrique peut être lavée lorsque le module est installé dans une enveloppe appropriée. Avant de laver cette partie, s'assurer que les joints toriques sont en bon état, que la plaque frontale est intacte et bien fixée à l'appareil et que le capuchon est bien installé.
- Le câble système du VAT doit être situé à une distance d'au moins 6 mm (0,25 po) des fils de détection et d'autres circuits dans l'enveloppe électrique.
- Dans des installations à vibrations élevées, fixer le module d'isolement à une surface à l'aide de vis pour éviter d'endommager le VAT et attacher les fils de détection et le câble système pour éviter toute contrainte aux points de connexion.
- Le VAT VeriSafe est conçu pour être utilisé dans des systèmes électriques de 50 ou 60 Hz.
- S'assurer que tous les fils de détection sont correctement raccordés et fixés au conducteur d'alimentation ou à toute autre partie rigide à proximité afin d'empêcher leur mouvement si le raccordement venait à être endommagé.
- Le VAT VeriSafe 2.0 est conçu pour être utilisé dans les systèmes électriques c.c. et les systèmes électriques c.a. de 50 ou 60 Hz. Le VAT ne doit pas être installé sur les sections d'un circuit où le VAT est exposé à une énergie à haute fréquence comme dans le cas de variateurs de fréquence (VFD) ou d'autres éléments de circuit générant une énergie à haute fréquence (formes d'onde présentant une forte interférence électromagnétique [EMI]). Pour obtenir plus d'informations sur le bon positionnement du VAT VeriSafe 2.0 dans les applications de VFD, consulter la note technique accessible en ligne sur [panduit.com](http://panduit.com).

Si un problème survient pendant l'installation, l'utilisation ou l'entretien du VAT VeriSafe 2.0, contacter le soutien technique de Panduit. Communiquer également avec Panduit en cas de problème avec la sécurité fonctionnelle du produit. Le numéro de modèle et le numéro de série du produit sont imprimés sur les étiquettes des modules d'isolement et d'indication.



Les modules d'isolement et d'indication du VAT VeriSafe 2.0 contiennent tous deux des cartes de circuits électroniques. Le module d'indication contient également une pile au lithium qu'il faut retirer à la mise hors service. Ne pas jeter la pile dans la poubelle; l'apporter plutôt à une installation de recyclage de piles appropriée. Les modules d'isolement et d'indication peuvent être apportés à une installation de recyclage d'appareils électroniques.

# System Configuration

## COMPONENTS

- 1 Isolation Module**
- 2 System Cable**
- 3 Indicator Module**  
3.6V Battery Powered option shown  
Battery Free option available
- 4 Instruction Label**  
Place a Label for each Indicator used
- 5 Warning Label**  
For Hazardous Locations, place label on exterior of enclosure near Indicator Module

## PART NUMBER IDENTIFICATION

VS2-AVT-XYZ-##

VS2-AVT	XY Power System	Z Indicator	## System Cable
VeriSafe 2.0 AVT	<b>3P</b> = Three-Phase System <b>1P</b> = Single-Phase / DC System	<b>F</b> = Battery Free Indicator <b>B</b> = Battery Powered Indicator	<b>02</b> = 2' (0.6m) System Cable <b>08</b> = 8' (2.4m) System Cable <b>16</b> = 16' (4.8m) System Cable

**NOTE:** Accessories are available for the VS2-AVT, refer to [www.panduit.com](http://www.panduit.com).

**NOTE:** Indicator Module Models VS2-AVT-xIF and VS2-AVT-xIB shall only be connected with the Isolation Module Model VS2-AVT-xP-ISO [x denotes single-phase / DC (1) or three-phase (3)]

## POWER FOR AVT TEST

Battery	Auxiliary DC	Power over Ethernet (PoE)*
<ul style="list-style-type: none"> <li>3.6V lithium industrial battery.</li> <li>Replace without opening the enclosure.</li> </ul>	<ul style="list-style-type: none"> <li>12 - 24 VDC</li> <li>Must be available when main is de-energized.</li> <li>Aux power is only used for powering the AVT in use cases without the network module*. Do not apply power to the AVT when using the network module*.</li> </ul>	<ul style="list-style-type: none"> <li>10/100 PoE</li> <li>IEEE 802.3af Type 1 Class III PoE topology.</li> </ul>

\* Refer to network module instruction manual, available at [www.panduit.com](http://www.panduit.com).

## DC POWER INPUT

The 2.0 AVT includes an optional DC Power Input.

**IMPORTANT** The power supply must be surge protected, otherwise external surge protection is required at the input to the supply.

Recommended Wiring	DC Input and Connector Specifications
<p>This connection features a pluggable screw-terminal connector and is used for DC power input or connection to the network module (optional).</p>	<ul style="list-style-type: none"> <li>Approved Power Source Type: IEC Class I regulated power supply; 12 - 24 VDC, 50 mA (minimum) output</li> <li>Power Requirement: 35 mA max @ 12 VDC; 17 mA max @ 24 VDC</li> <li>Connector / Wiring Requirements;                     <ul style="list-style-type: none"> <li>Wire Range: (1 wire): AWG #24 - 12 [2.5mm<sup>2</sup>] SOL / STR</li> <li>(2 wire): AWG #18 [1.0mm<sup>2</sup>] SOL</li> <li>AWG #18 [1.5mm<sup>2</sup>] STR</li> </ul> </li> <li>Wire strip length: 7.0mm (min) / 8.0mm (max)</li> <li>Screw Drive Size: M3x0.5</li> <li>Screw Torque Required: 5.0 in-lb [0.57 N-m] +/- 10%</li> </ul>



## INDICATOR MODULE

The 2.0 AVT isolation module is compatible with up to two indicator modules. The test can be initiated at either location and results will be shown simultaneously on both indicators. Primary indicator must be installed locally near the isolation module. A combination of battery-powered and battery-free indicators can be used in either port. Refer to the table below for maximum system cable length.

	Indicator Module Port	Indicator Type(s) Supported	Maximum System Cable Length
	INDICATOR (Primary Indicator)		Battery Free
Battery Powered (see NOTE 2)			30 feet (9.1 m)
AUX (Auxiliary Indicator, see NOTE 1)		Battery Free	500 feet (152.4 m)
		Battery Powered (see NOTE 2)	500 feet (152.4 m)
<b>NOTES:</b> <ol style="list-style-type: none"> <li>AUX port does not accept battery power.</li> <li>Battery powered indicator module can be used in the AUX port, however the battery will not have any impact on powering the AVT.</li> </ol>			

## ABSENCE OF VOLTAGE OUTPUTS

The AVT includes a set of redundant isolated transistor outputs for optional use with control systems. These outputs are located on the isolation module. These outputs are normally inactive, and are only active when the green absence of voltage indicator is illuminated. By utilizing these outputs, the AVT can be used to interface with a control system.

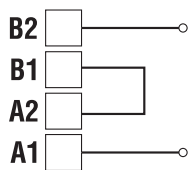
	Recommended Wiring	Output Specifications
	<p>For redundant monitoring of output state. Outputs are normally inactive, and active only when absence of voltage is detected.</p> 	<ul style="list-style-type: none"> <li>NPN Transistor output</li> <li>8kVrms Input/Output Isolation</li> <li>Applied Voltage maximum 24 VDC</li> <li>Load Current 80 mA DC</li> <li>SIL3 compliant</li> <li>Duty Cycle: 10 seconds per test cycle</li> <li>Connector / Wiring Requirements                             <ul style="list-style-type: none"> <li>Wire Range: AWG #26 - 16 SOL / STR (1 wire only)</li> <li>Wire strip length: 9.0mm (min) / 10.0mm (max)</li> </ul> </li> </ul>

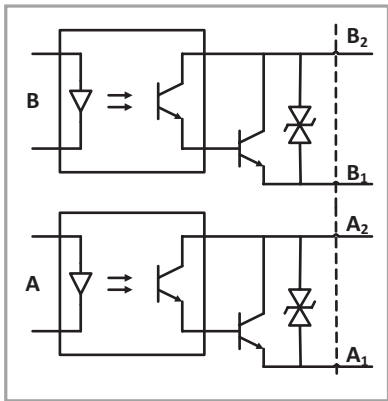

ISOLATED NPN OUTPUTS

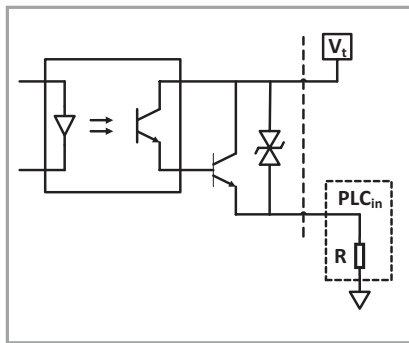

SOURCING

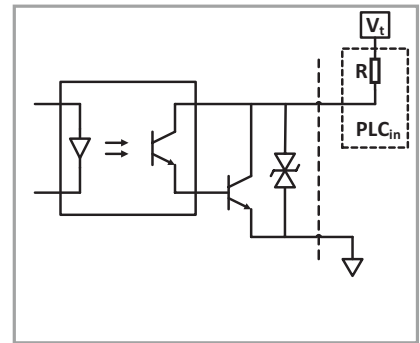

SINKING

# Technical Specifications



**WARNING:** Do not use this product outside of the specified performance and environmental limits. **Failure to comply with these specifications could result in product failure, personal injury, or death.**



**WARNING:** The VeriSafe 2.0 AVT is designed for use in 50 or 60Hz AC electrical systems and DC electrical systems. The AVT should not be installed on sections of a circuit where the AVT is exposed to high frequency energy such as variable frequency drives (VFD) or other circuit elements generating high frequency energy (waveforms exhibiting high Electro-Magnetic Interference (EMI)). For more information on where to position the VeriSafe 2.0 AVT in VFD applications, see the Technical Note available on Panduit.com.

## Special Conditions of Use



### Hazardous Locations

- Refer to Page 2 of this manual for all Special Conditions of Use for Hazardous Locations.

## Environmental Ratings

Operating Temperature	-25°C to 60°C (-13°F to 140°F)
Storage Temperature	-45°C to 85°C (-49°F to 185°F)
Humidity	5 to 90% non-condensing; Rated 80% at 40°C (104°F), decreasing linearly to 50% at 60°C (140°F)
Pollution Degree	3
Altitude	Up to 5000 meters (16400 feet)

## Applications

Electrical System	For use in 3-phase AC systems, single-phase AC systems and DC systems
Voltage Detection Range	Up to 1000 VAC (50 or 60 Hz), 1000 VDC
Absence of Voltage Threshold	3 V (See the Installation Considerations section for additional information)
Overvoltage Category	III (1000 V), IV (600 V)
Degree of Protection	<u>Indicator Module:</u> for flat surface mounting in a TYPE (UL, NEMA and CSA) 1, 12, 13, 4, 4X, IP66, IP67 or IP69 enclosure. Verify that the seal, o-rings and gaskets are clean to ensure proper sealing. <u>Isolation Module:</u> Open Type, IP20.

## Power Requirements

Battery	Industrial 3.6 V Lithium. Refer to Maintenance section for list of approved batteries.
Auxiliary (DC) Power	35 mA max @ 12 VDC; 17 mA max @ 24 VDC
Power over EtherNet (PoE)	PoE (10/100), 15 mA, IEEE 802.at (-af) Type 1 Class III PoE topology

## Quiescent Current

Battery Powered	Per Phase: 0.85 mA rms @ 480 Vrms; 1.2 mA rms @ 1000 Vrms
Auxiliary (DC or PoE) Powered	Per Phase: 0.33mA rms @ 480 Vrms; 0.65mA rms @ 1000 Vrms

## Voltage Presence Indicators (Red LEDs) - Voltage Illumination Level

Voltage Illumination Level	AC System Voltage		DC System Voltage		
	Three-Phase	Single-Phase	3-Wire Center Ground	Positive or Negative Ground	Isolated Ground
Battery Powered	50 VAC	60 VAC	90 VDC	55 VDC	90 VDC
Auxiliary Powered (DC or PoE)	50 VAC	50 VAC	50 VDC	50 VDC	50 VDC

continued on next page

Functional Safety	
Mode of operation	Continuous, High Demand
Failure Rate	$\lambda_{SD}$ 488   $\lambda_{SU}$ 235   $\lambda_{DD}$ 267   $\lambda_{DU}$ 9   $S_{FF}$ 99.1%
Supported Safety Integrity Levels	SIL3
Demand Response Time	8.5 Seconds
Device Type	Type A
Systematic Capability	SC 3
Error Handling Response Time	12.1 Seconds
Reference Report	PAN 19/08-093 R001
Operating Modes	SIL mode only
Hardware Fault Tolerance (HFT)	0

Standards and Certifications	
UL 1436	Standard for outlet circuit testers and similar indicating devices
CAN/CSA-C22.2 No. 160	Voltage and polarity testers
IEC / UL / CSA C22.2 NO. 61010-1 IEC / UL / CSA C22.2 NO. 61010-2-030	Safety requirements for electrical equipment for measurement, control, and laboratory use
UL 508 & CSA-C22.2 No. 14	Industrial control equipment
IEC 61508-1, -2, and -3 {SIL 3 Rating}	Functional safety of electrical/electronic/programmable safety-related security systems
FCC - CFR 47 Part 15 Subpart B	Radio frequency devices
CAN ICES-001	Industrial, scientific and medical (ISM) radio frequency generators
EN 55011, CISPR 11 AS/NZS CISPR 11	Radio frequency disturbance characteristics
IEC / EN 61326-1, -3-1	EMC and immunity requirements
IEC / EN 61000-3-2, -3-3, -6-2	Electromagnetic compatibility (EMC)
CE UKCA	Conformity Marking for European Economic Area Conformity Marking for United Kingdom
RoHS	Restriction of hazardous substances

**NOTE:** By design and installation guidelines the VeriSafe 2.0 AVT is not impacted by the occurrence of phenomena from IEC 61000-4-16





# Dimensions

NOTES: UNITS = inches [mm]

## BATTERY POWERED INDICATOR MODULE

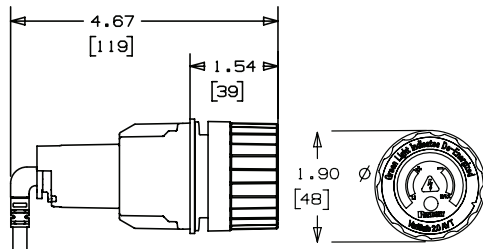

## BATTERY FREE INDICATOR MODULE

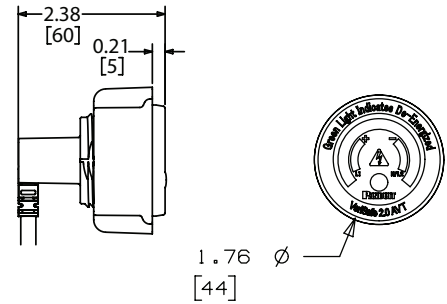

## PANEL KNOCKOUT (FOR INDICATOR MODULE INSTALLATION)

- The Indicator Module is designed for use with a standard **30 mm knockout** with notch.
- The notch should be positioned on top as shown in the image shown.
- The VeriSafe AVT indicator module can be installed into a **maximum panel thickness of 0.25" [6.4]**.

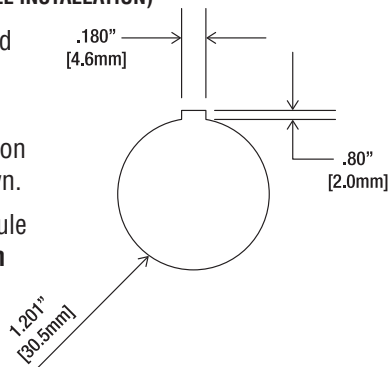

## INSTRUCTION LABEL

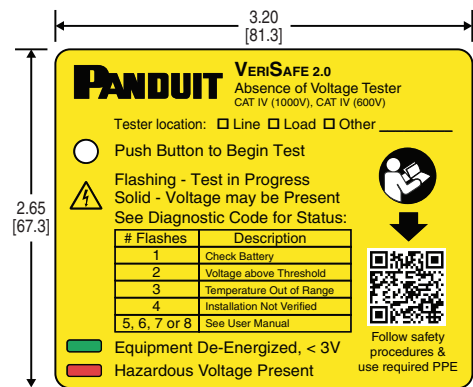

## ISOLATION MODULE

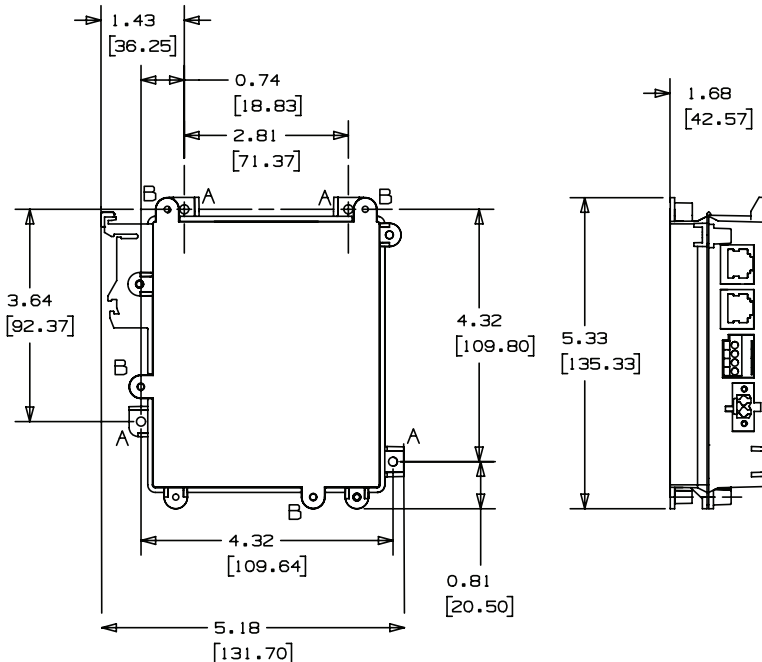

# Schematics



**WARNING:**

- The AVT must be installed correctly and grounded as described in this Instruction Manual to provide proper indication of absence of voltage. Sensor leads must not be mechanically connected with each other for the device to verify connection to the circuit. Correct function of the device must be verified after installation, see Commissioning Checklist section, p. 15. Failure to comply with these instructions could result in product failure, injury or death.
- Sensor leads of the same labeled set (i.e.; L1, L2, L3 and GND) should be terminated on the same conductor. Each conductor should have at least one sensor lead set, as shown on the schematic diagrams.

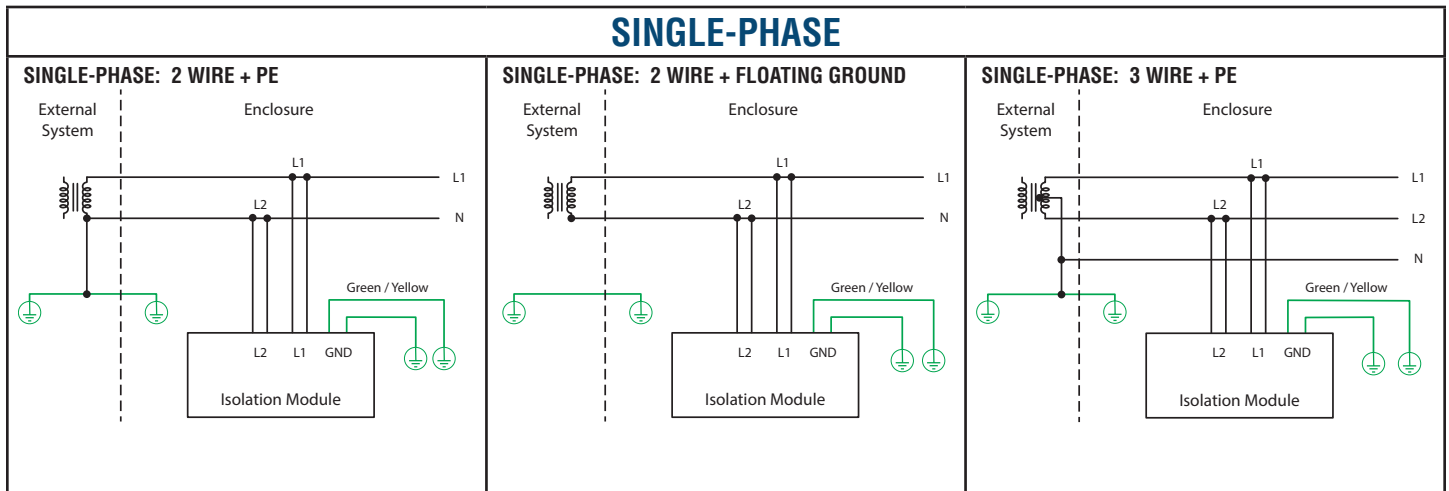
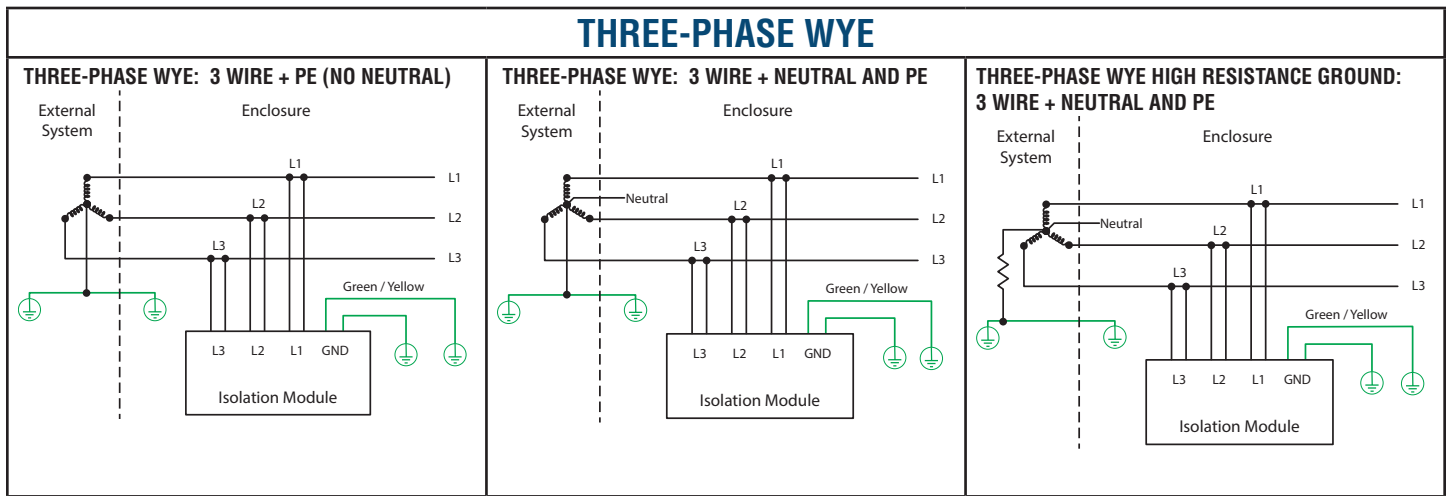
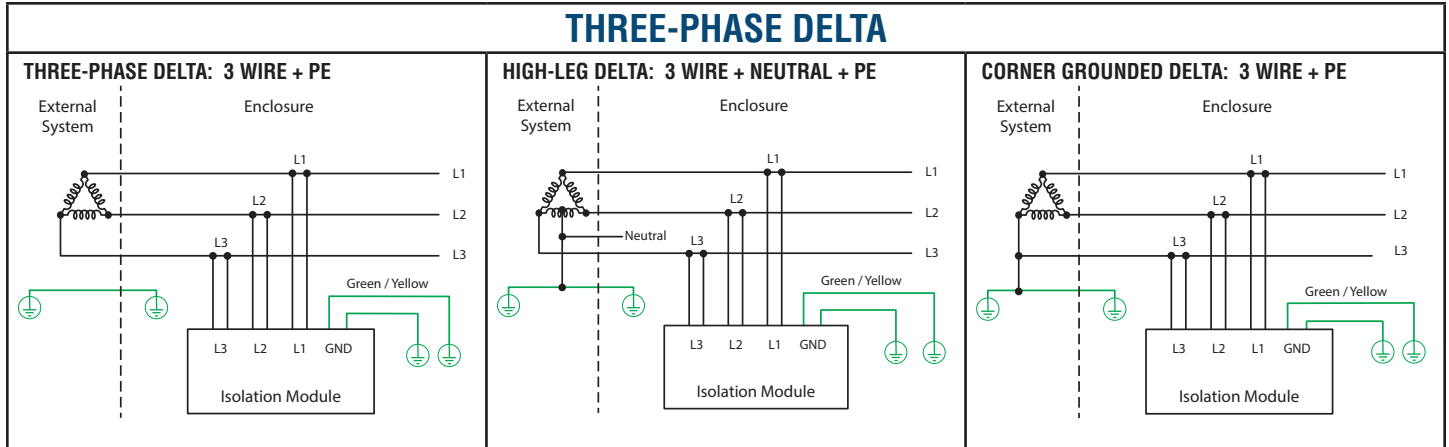

continued on next page

# Schematics (cont.)

## DC SYSTEMS

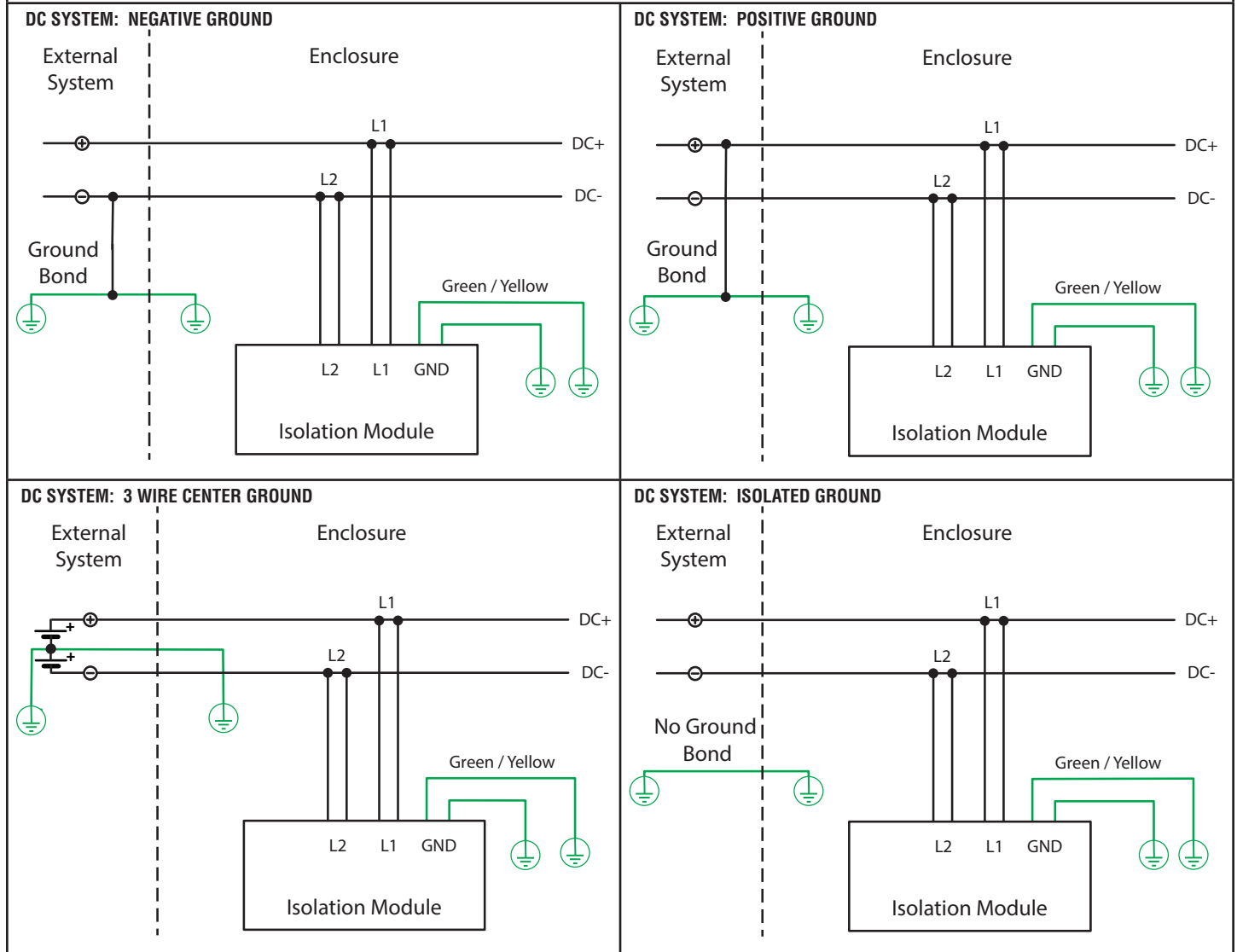

# Installation Considerations

This section provides guidelines for installing the 2.0 AVT. It also addresses common application scenarios and describes best practices.

## GENERAL INFORMATION

Before installing the AVT, identify all sources of electrical energy in the equipment. Install the AVT at the point in the circuit where you would normally test for voltage. The AVT will only test for voltage at the point where it is installed. If there are multiple energy sources or multiple test points, consider using multiple AVTs. Mark the test location on the yellow instruction label. Apply this label to outside of enclosure near the indicator module. There should not be any circuit elements (ex. circuit breaker, fuse, VFD, switch or similar control devices, etc.) installed between each pair of sensor leads. Although the absence of voltage threshold is 3.0 V, residual voltages should be less than 2.7 V to ensure proper function.

## EFFECT ON SHORT CIRCUIT CURRENT RATING (SCCR)

AVTs listed to UL 1436 are required to operate as a secondary circuit that is isolated from the circuit conductors by use of a transformer, optical isolator, or limiting impedance, or other similar means. This is intended to reduce the risks of both electric shock and thermal hazard. These isolation circuits allow very limited current flow, if any, through the AVT.

The VeriSafe 2.0 AVT is suitable for use on circuits delivering up to 300,000 rms symmetrical A at 1000 V.

AVT sensor lead terminations should be made via a tap to the circuit conductor using connectors, terminal strips, or power distribution blocks, etc. which are rated for the application. It is generally preferred to use connection methods that DO NOT pierce or otherwise compromise the integrity of the conductor. Connectors that require conductors to be cut or spliced can be used but may limit the SCCR.

## USE OF OVERCURRENT PROTECTION

Installation of an AVT with overcurrent protection is neither required nor recommended. UL 1436 requires AVTs to be constructed so that internal component failures will not expose the AVT to available short circuit currents from the main power supply during normal operation and under single-fault conditions. The 2.0 AVT uses high impedance to limit voltage and current flow through the device to safe levels. In addition, the AVT has been tested to withstand transient overvoltage up to 8 kV.

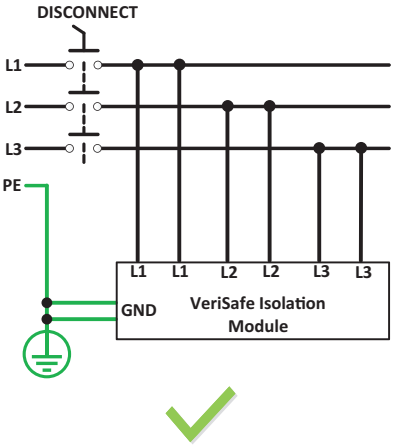
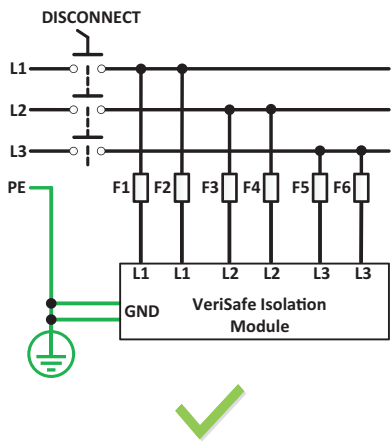
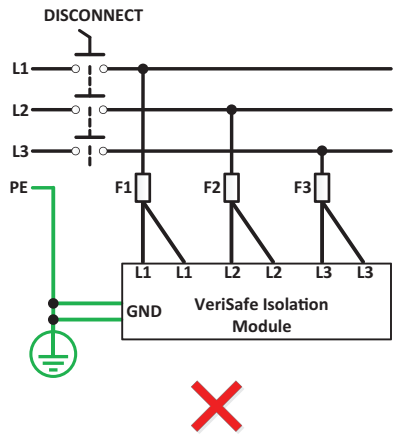
<p>If the AVT sensor leads are not longer than 10 feet, they can be treated as a feeder circuit and do not require overcurrent protection [NFPA 70:2020 240.21(B)(1)(b) Exception and CSA C22.1:21 14-100(b)]</p>	<p>In certain regions and countries, additional overcurrent protection is required to conform to standards such as AS/NZS3000. Do not install multiple sensor leads on one overcurrent protection device. Sensor lead pairs must not be electrically connected in the event that the overcurrent protection is in the open state. Do not install overcurrent protection on the two green ground leads.</p>	
		

# Installation Instructions

## Special Conditions of Use



### WARNING:



## Hazardous Locations

- Refer to Page 2 of this manual for all Special Conditions of Use for Hazardous Locations.

- The AVT must be installed correctly and grounded as described in this Instruction Manual to provide proper indication of absence of voltage. Sensor leads must not be mechanically connected with each other for the device to verify connection to the circuit. Correct function of the device must be verified after installation, see Commissioning Checklist section, p. 15.
- Sensor leads of the same label designation should be terminated on the same conductor (L1, L2, L3, GND). Each conductor should have at least one sensor lead set, as shown on the schematic diagrams.
- Excess length from Sensor Leads should be trimmed; lead wires should not be extended with a splice. When using terminal or power distribution blocks, the total length of the sensor leads from the isolation module to the source conductors shall not exceed 10 feet (3.0m).
- Always comply with local installation codes and standards.
- Always follow safety and lockout/tagout procedures when working on or near electrical systems and equipment.

**NOTE:** Before installation, verify that after power is removed from the circuit to be monitored. The potential measured between each line and ground should be less than 2.7V, including voltages on the line from auxiliary systems.

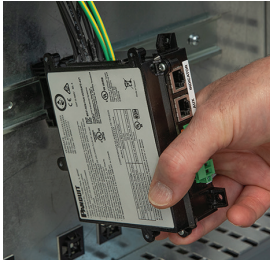
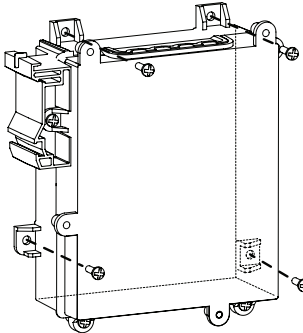
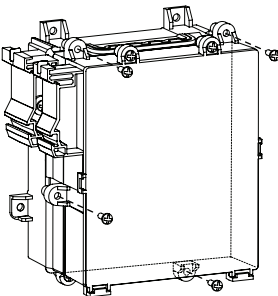
<b>ISOLATION MODULE</b>		<b>NETWORK MODULE</b>
<p><b>DIN-RAIL MOUNTING</b> Snap the Isolation Module onto the DIN rail.</p> 	<p><b>OR</b></p> <p><b>SURFACE MOUNTING</b> Mount the isolation module to any surface using four #6 [M3.5] pan head screws or another compatible fastener. Surface mounting with screws is recommended for high vibration environments</p> 	<p><b>ATTACHING NETWORK MODULE TO ISOLATION MODULE (OPTIONAL)</b> If mounting to isolation module, use screws provided with network module.</p> 

## SENSOR LEAD TERMINATION

- Route the sensor and ground leads.
  - The sensor leads should not be any longer than necessary and should be routed to avoid sharp edges, pinch points or mechanical damage.
  - There is no maximum distance limitation between the two leads on each phase, however there should not be any circuit elements installed between them.
  - Sensor leads should not be extended with a splice. When using terminal or power distribution blocks, the total length of the sensor leads from the isolation module to the source conductors shall not exceed 10 feet (3.0m).
- Terminate the sensor and ground leads.
  - Use of ferrules or terminals is recommended.
  - Sensor leads for each phase and ground must not be mechanically terminated at the same point for the AVT to function properly.
  - Sensor leads of the same label designation should be terminated on the same conductor (L1, L2, L3, GND). Each conductor should have at least one sensor lead set, as shown on the schematic diagrams.
  - Secure the sensor leads to the conductors and insulate the connections.

## AUXILIARY DC POWER (OPTIONAL)

If using DC power, connect the 12 or 24 VDC power source, see DC Power Input (page 5). The DC Power Input is marked for polarity; connect the positive output of the supply to the terminal marked (+) and the negative output of the supply to the terminal marked (-).

## INDICATOR MODULE AND INSTRUCTION LABEL

### BATTERY POWERED INDICATOR MODULE

1. Tighten the panel nut until both it and the gasket make full contact with the enclosure surface. Then, tighten an additional 1/4 turn.
2. Install battery into battery tray. The positive terminal should face the operator. Ensure the battery is fully seated before proceeding. See Battery Replacement section for details.
3. Install instruction label near the indicator module on the exterior of the enclosure. Mark the label to indicate where in the circuit the AVT is installed.
4. Install the cap label with the appropriate language, if other than English.

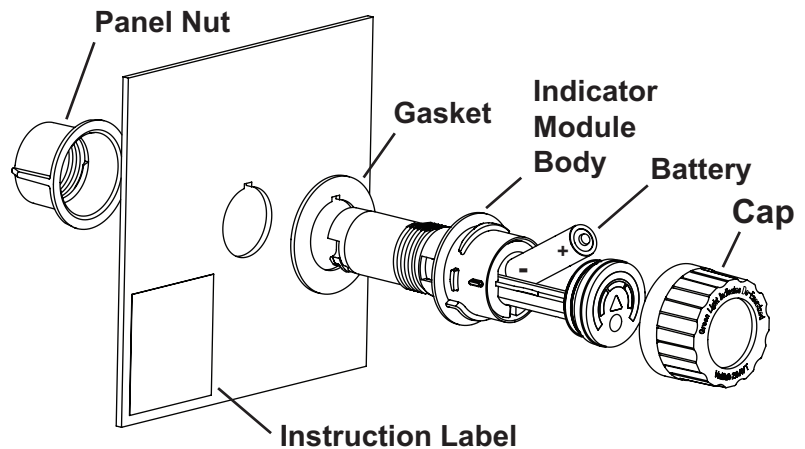

### BATTERY FREE INDICATOR MODULE

1. Tighten the panel nut until both it and the gasket make full contact with the enclosure surface. Then, tighten an additional 1/4 turn.
2. Install instruction label near the indicator module on the exterior of the enclosure. Mark the label to indicate where in the circuit the AVT is installed.
3. Install the cap label with the appropriate language, if other than English.

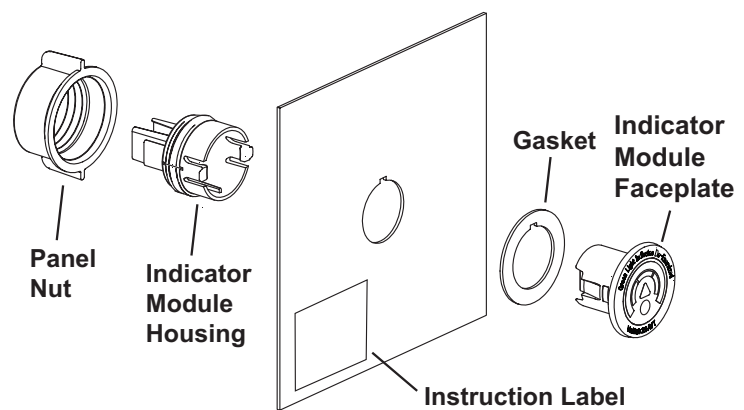

**NOTE:** The Instruction Label is UL approved for application to galvanized and stainless steel, ABS, polycarbonate, and polyester painted surfaces. It is up to the installer to verify proper bond to other surface types.

## SYSTEM CABLE

1. Insert the end of the system cable with the right-angle connector in the back of the indicator module. Press firmly into the opening until you feel it latch. Pull back on the connector to verify that it has properly latched.
2. Insert the keyed-end of the system cable into the isolation module port labeled INDICATOR. System cable for an additional indicator (optional) may be inserted into the isolation module port labeled AUX.

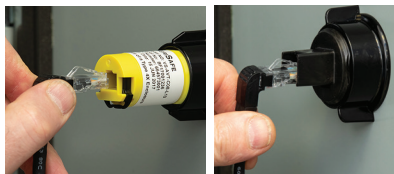

Battery Powered

Battery Free



- The system cable must be separated from the sensor leads and other circuits in the electrical enclosure by a minimum of 0.25 inches (6 mm).
- The maximum allowable system cable length for the INDICATOR port is 30 ft (9.1m).
- The maximum allowable system cable length for AUX port is 500 ft (152m).
- If the system cable is routed outside of the enclosure that contains the isolation module, the system cable must be installed in a conduit. When installed in conduit, the system cable should be regarded as a data cable and must not use the same conduit as the electrical power conductors.



# Commissioning Checklist:

**IMPORTANT** REPEAT THE COMMISSIONING CHECKLIST WHEN CHANGES TO THE ELECTRICAL SYSTEM ARE MADE. COMMISSIONING TEST RESULTS SHALL BE RECORDED.

## Special Conditions of Use



## Hazardous Locations

- Refer to Page 2 of this manual for all Special Conditions of Use for Hazardous Locations.

- De-energize the circuit that is being monitored by the AVT.
- Visually inspect the AVT.
  - **AVT system cable:** Verify cable is locked into place on both the indicator module and isolation module.
  - **DC power input:** If an external DC power source is used to power the AVT, ensure the wiring from DC power source is connected and properly terminated into screw-terminal connector. Ensure connector is fully seated. Ensure the DC power source is fully functional.
  - **Indicator module(s):** Ensure o-ring and gaskets are in place. Check that retaining nut is secure. Verify battery is installed and battery cap is locked into place (if applicable).
  - **Isolation module:** Ensure module is secured to subpanel or DIN rail.
  - **Sensor leads:** Gently pull on each sensor lead to ensure termination is secure.
    - Verify no wiring is exposed and all terminations are properly insulated.
    - Verify that leads are connected as described in the appropriate wiring diagram from the Schematic section, including verifying that each conductor has two lead wires of matching label designation with no circuit elements between each pair.
    - Verify leads on each phase are not mechanically connected to each other.
  - **Instruction label:** Verify that a label is placed near each indicator module and marked to indicate where the AVT is installed.
- Record changes to panel documentation.
- Close panel and secure doors/covers.
- Press the test button to initiate the test. The yellow caution indicator should flash rapidly to indicate the test is in progress followed by the absence of voltage indicator illuminated green.
- Review the Operating Instructions section of this manual before proceeding.



**WARNING:** Always follow your company's safety procedures when energizing equipment. To avoid electric shock, use proper personal protective equipment when working on or near electrical hazards.

- Energize the system being monitored by the AVT.
  - Verify that the red voltage presence indicators are illuminated.
  - Press the test button on the indicator module to initiate the absence of voltage test.
  - Look for the yellow caution indicator to flash repeatedly before turning to a solid indication  
\*\*You should not see the green indicator illuminate when power is energized\*\*
  - Repeat for each indicator module
- De-energize the circuit that is being monitored by the AVT.
  - Verify that voltage presence indicators are not illuminated.
  - Press the test button on the indicator module to begin the absence of voltage test. Look for the yellow caution indicator to flash and then the green absence of voltage indicator should illuminate.
  - Repeat for each indicator module.

# Operating Instructions



**WARNING:**

- To avoid electric shock, always de-energize power before entering an electrical enclosure.
- Always follow safety and lockout/tagout procedures when working on or near electrical systems and equipment.
- Use proper personal protective equipment (PPE) when working around sources of hazardous electrical energy.
- The product must be installed and commissioned by a qualified electrical worker familiar with local and national electrical codes.
- The AVT will only test for absence of voltage at the point in the circuit where it is installed. If there are other sources of power in the equipment, dangerous voltage may be present.
- Lack of red voltage presence indicators alone does not verify the absence of voltage, the absence of voltage test must be initiated followed by the illumination only of the green indicator to verify the absence of voltage.

The AVT should only be operated by individuals who have been trained on the operation of the tester and can demonstrate knowledge of the following criteria:

- Familiar with requirements and information in the Instruction Manual and understand the function of the AVT, meaning of the indicators and markings, and limitations of the Voltage Presence Indicators.
- Aware of where the AVT is installed in the electrical system and any additional electrical hazards that may be present in the system that are not detectable by the AVT.
- Able to recognize electrical hazards and familiar with lockout/tagout procedures.

Indicator Module Faceplate	
	<p><b>TEST BUTTON:</b> Initiates test</p> <p><b>ABSENCE OF VOLTAGE INDICATOR:</b> Illuminates <b>green</b> when the absence of voltage is verified.</p> <p><b>CAUTION INDICATOR:</b> Flashes <b>yellow</b> rapidly to indicate test in process, illuminates solid to indicate the test has failed and flashes after a solid illumination to indicate the reason for failure, see Troubleshooting section for additional information.</p> <p><b>VOLTAGE PRESENCE INDICATORS:</b> The <b>red</b> indicators illuminate when the presence of hazardous voltage is detected. <b>Lack of red voltage presence indicators alone does not verify the absence of voltage.</b></p>

<p><b>VOLTAGE PRESENCE INDICATORS</b></p> <p>A. When voltage is detected in one or more phases, the appropriate voltage presence indicators will illuminate.</p> <p>B. Lack of red voltage presence indicators alone does not verify the absence of voltage. To test for absence of voltage, push the test button.</p>	
--	--



<p><b>ABSENCE OF VOLTAGE TEST</b></p> <p>Each time the test button is engaged, the absence of voltage test sequence will be activated. The test sequence includes running a self-check, using a known voltage source to test-the-tester to verify that the AVT is functioning, testing for AC and DC voltage phase-to-phase and phase-to-ground, and verifying the sensor leads are in contact with circuit conductors.</p> <ol style="list-style-type: none"> <li>1. De-energize the circuit according to company safety procedures.</li> <li>2. Verify that lockout/tagout devices have been applied to all applicable energy sources and the voltage presence indicators are not illuminated.</li> <li>3. Press the test button to initiate the absence of voltage test.</li> <li>4. The caution indicator will begin to flash. This indicates that the test is in progress.</li> <li>5. When the absence of voltage is verified, the absence of voltage indicator will illuminate.</li> <li>6. If the absence of voltage is not verified, the caution indicator will illuminate for about five seconds followed by a series of flashes. The number of flashes will help diagnose why the test failed. Refer to the Troubleshooting section for additional information.</li> </ol>	
---	--

# Troubleshooting

**WARNING:** 

- Always de-energize power before accessing an electrical enclosure.
- Always follow safety and lockout/tagout procedures when working on or near electrical systems and equipment.
- Use proper personal protective equipment (PPE) when working around sources of hazardous electrical energy.
- Battery, system cable, o-rings and gaskets can be replaced. No other part of the product is serviceable. Do not attempt to open the indicator module or isolation module for repair or modification. When servicing this product, only use specified replacement parts.
- Use only 2.0 AVT system components (system cable, isolation module, indicator module). Do not use a standard Ethernet cable. Do not use 1.0 AVT system components with 2.0 AVT system components.

If absence of voltage is not confirmed the caution indicator will illuminate for approximately 5 seconds. If absence of voltage is not confirmed, illumination of the caution indicator will be followed by a number of brief flashes ranging from 1-8 . The number of flashes can be used to determine why the absence of voltage was not confirmed.

Number of Flashes	Description	Recommended Actions
1	Battery voltage too low to run the test	Replace the battery and re-test
2	Voltage detected above the threshold	 <b>WARNING: This indicates that the enclosure is energized</b> <ul style="list-style-type: none"> <li>■ Follow safety procedures and use the appropriate PPE when investigating the source of voltage</li> <li>■ If panel has a stored energy source, wait several minutes then re-test to see if energy has dissipated</li> </ul>
3	Temperature out of range	<ul style="list-style-type: none"> <li>■ Verify that the temperature of the isolation module is within the acceptable range.</li> </ul>
4	Proper installation of the sensor leads could not be verified	 <b>WARNING: The enclosure may be energized</b> <ul style="list-style-type: none"> <li>■ Follow safety procedures and use the appropriate PPE when verifying the enclosure is de-energized before performing additional troubleshooting</li> <li>■ Refer to the Installation Instruction section and verify that the sensor leads are installed properly, and that the device is grounded properly</li> </ul>
5, 6, 7, or 8	Hardware failure	<ul style="list-style-type: none"> <li>■ Contact Panduit Technical Support for additional troubleshooting</li> </ul>

**If the caution indicator does not illuminate after pressing the test button**

1. Verify the system cable is fully engaged into the connectors on the indicator and isolation module. The indicator module will not function if it is not connected to the isolation module.
2. Verify power is applied to the AVT
  - Battery
    - Verify the battery tray is fully engaged in the indicator module housing with the cap installed.
    - Replace the battery. If the battery voltage is too low, the indicator module will not operate.
  - DC Input
    - Verify external power source is functional and all wiring is installed properly.
    - Verify DC input terminations are secure and polarity is correct.
    - Verify DC supply is available when the test location is de-energized.
  - Network Module
    - Verify the connections between the network module and isolation module are properly terminated.

**Should a problem occur during installation, operation or maintenance of the VeriSafe 2.0 AVT, contact Panduit Technical Support.**

# Maintenance

**WARNING:** 

- The battery powered indicator module contains a lithium battery that is a fire, explosion and severe burn hazard. Do not crush, recharge, disassemble or heat above 85°C (185°F), incinerate, or expose contents to water.
- The AVT will not work with a standard alkaline 1.5 V AA battery. Use only Panduit approved battery.
- Battery, system cable, o-rings and gaskets can be replaced. No other part of the product is serviceable. Do not attempt to open the indicator module or isolation module for repair or modification. When servicing this product, only use specified replacement parts.
- The o-rings and gaskets can be replaced if they become dry or brittle. In critical sealing applications, such as wash down environments, it is recommended that the o-rings and gaskets be replaced every 5 years. Apply a light coating of silicone grease to the o-rings to promote sealing and extend o-ring life.

<b>Special Conditions of Use</b> 	<b>Hazardous Locations</b> ■ Refer to Page 2 of this manual for all Special Conditions of Use for Hazardous Locations.
--	---

## VISUAL INSPECTION

- Periodically inspect the AVT and replace any damaged parts, cables or terminations.
- Inspect the sensor lead terminations to ensure they are tight, the leads are secure, and does not show signs of damage.
- Inspect the system cable to ensure it is locked into place on both ends, is secure and does not show signs of damage.
- Inspect the indicator module to ensure o-rings or gaskets are not dry or brittle.
- Inspect the indicator module to ensure the retention nut is tight and cap is firmly in place.

## CLEANING INSTRUCTIONS





The indicator module can be cleaned with a damp cloth or isopropyl alcohol based cleaner. Do not use abrasives or high alkaline cleaners. Do not leave cleaners on the device for a long period, rinse immediately. Do not apply cleaners in direct sunlight or elevated temperatures.

Before a wash down operation, ensure the o-rings and gaskets are in good condition, the faceplate is not damaged and fully secured to the unit, and the cap is fully installed.

## BATTERY REPLACEMENT

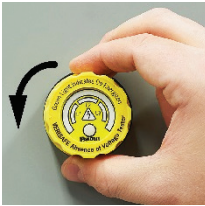
 Follow the steps below to replace the battery. The table below provides the list of batteries approved for use with the AVT. Do not discard the battery in the trash; take it to an appropriate battery recycling facility.

Panduit Part No.	Manufacturer	Mfr. Model No.	Size	Description	Operating Temperature
VS-AVT-BATTERY	Titus	ER14505M	ER14505	3.6 Volt Lithium Battery	-25°C to 60°C (-13°F to 140°F)

<p><b>1.</b> Twist the indicator module cap counterclockwise approximately 90 degrees, until you feel a stop.</p> 	<p><b>2.</b> Grip the battery tray and slide it out until you feel a stop. The battery tray is not intended to be fully removed.</p> 	<p><b>3.</b> Remove used battery. Install a new battery. Ensure the battery is fully seated before proceeding.</p> 	<p><b>4.</b> Slide the battery tray back in the housing. A self test is initiated when the battery tray is inserted and connection is made between the battery and AVT electronics.</p> 	<p><b>5.</b> Replace the cap.</p>  <p>Twist cap clockwise to lock into place.</p>	
<p><b>6.</b> Record the date the battery was replaced in equipment documentation.</p>					

## SYSTEM CABLE REMOVAL (BATTERY POWERED INDICATOR MODULE)

 <p>RIGHT-ANGLE CONNECTOR</p> <p>RETENTION SPRING</p>	<ol style="list-style-type: none"> <li>1. Grip the retention spring on both sides.</li> <li>2. Pull down on the retention spring approximately 1/16 inch [1.5 mm].</li> </ol> 	<ol style="list-style-type: none"> <li>3. Continue holding the retention spring down while pulling back on the right-angle connector to release the system cable.</li> </ol> 
--	--	--

## O-RING AND GASKET REPLACEMENT

The o-rings and gaskets can be replaced if they become dry or brittle. In critical sealing applications, such as wash down environments, it is recommended that the o-rings and gaskets be replaced every 5 years.

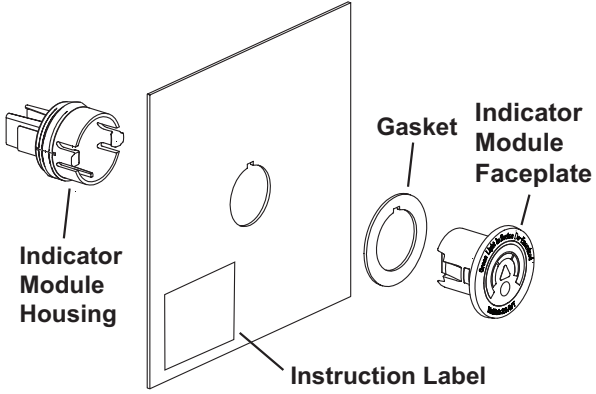
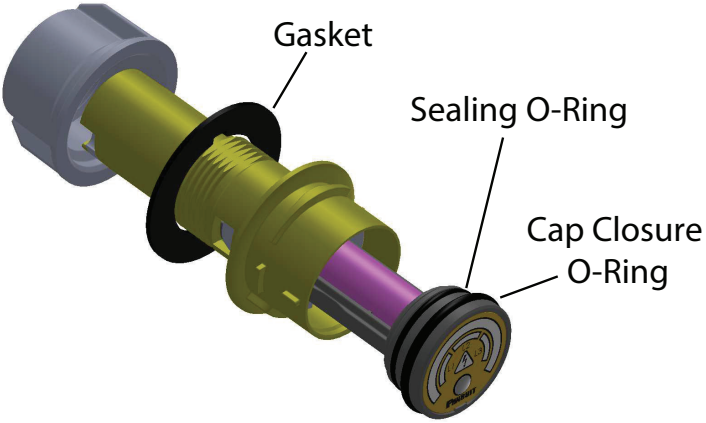
<p><b>BATTERY FREE INDICATOR MODULE</b></p> <p>For the battery free indicator module, order Panduit SKU <b>VS2-AVT-GASKET</b> for gasket replacement kit.</p> <ol style="list-style-type: none"> <li>1. Unplug the system cable and remove the panel nut.</li> <li>2. Squeeze the top and bottom of the housing and pull back to release the latches from the faceplate.</li> </ol>  <ol style="list-style-type: none"> <li>3. Separate housing from faceplate and replace gasket.</li> </ol>  <p>Indicator Module Housing</p> <p>Indicator Module Faceplate</p> <p>Gasket</p> <p>Instruction Label</p>	<p><b>BATTERY POWERED INDICATOR MODULE</b></p> <p>For the battery powered indicator module, order Panduit SKU <b>VS-AVT-ROR</b> for o-rings and gasket replacement kit.</p> <ol style="list-style-type: none"> <li>1. Unplug the system cable and remove the panel nut.</li> <li>2. Replace the gasket and o-rings.</li> <li>3. Apply a light coating of silicone grease to the o-rings to promote sealing and extend o-ring life.</li> </ol>  <p>Gasket</p> <p>Sealing O-Ring</p> <p>Cap Closure O-Ring</p>
---	--



# Warranty

## PANDUIT LIMITED PRODUCT WARRANTY

- 1. Limited Product Warranty.** For purposes of this Limited Product Warranty, “**Panduit products**” mean all Panduit-branded products that Panduit sells. Unless a different time period is set forth in the Panduit product manual, user guide or other product documentation, Panduit warrants that the Panduit product, and each part or component of the Panduit product, will comply with Panduit’s published specifications and will be free from defects in material and workmanship for a period of 1 year from the date of invoice from Panduit or its authorized distributor, not to exceed 18 months from the original date of shipment from Panduit’s facility.
- 2. Firmware.** Unless otherwise provided in a separate license agreement, and subject to the limitations for third-party products set forth below, Panduit warrants that any firmware contained in any Panduit products, when used with Panduit-specified hardware and when installed properly, will perform in accordance with the Panduit published specifications for a period of 1 year from the date of invoice from Panduit or its authorized distributor, not to exceed 18 months from the original date of shipment from Panduit’s facility. Any exceptions to this 1 year warranty period will be identified in the Panduit product manual, user guide or other product documentation. Panduit does not warrant that the operation of the firmware will be uninterrupted or error-free, or that the functions contained therein will meet or satisfy Buyer’s intended use or requirements. Any warranties, if any, that Panduit provides for any standalone software that Panduit sells will be stated in the applicable End User License Agreement.
- 3. Remedies.** Panduit’s sole and exclusive obligation and Buyer’s exclusive remedy under this warranty is Panduit’s repair or replacement of the defective Panduit product. Panduit shall have sole discretion as to which of these remedies Panduit will provide to Buyer. Buyer requested on-site warranty service is not covered and will be at Buyer’s sole expense, unless authorized in writing by Panduit in advance of the commencement of the on-site warranty service. Panduit has the right to either examine the Panduit products where they are located or, in its sole discretion, issue shipping instructions for return of the product. Where applicable, Buyer must return the defective product, part or component, transportation prepaid to Panduit’s customer service department accompanied by Panduit’s Return Material Authorization. If Panduit confirms that there is a defect that is covered by this warranty, the repaired or replaced Panduit product will be warranted for the remainder of the warranty period applicable to the originally shipped Panduit product, or for a period of 90 days from the date of shipment to Buyer, whichever is longer.
- 4. No Warranty for Third-Party Products.** Panduit makes no representations and disclaims all warranties of any kind, express or implied relative to any third-party product or services, including any third-party software or firmware, which may be incorporated into a Panduit product and/or resold or sublicensed by Panduit. To the extent any warranties extended to Panduit by the third-party manufacturer are transferable, Panduit will transfer such warranties to Buyer and any enforcement of such third-party warranties shall be between the Buyer and the third-party. Panduit does not warrant the compatibility of the Panduit products with the products of other manufacturers or Buyer’s application except to the extent expressly represented in Panduit’s published specifications or written quotation.
- 5. Exclusions.** Before using, Buyer shall determine the suitability of the Panduit product for his intended use and Buyer assumes all risk and liability whatsoever in connection therewith. The warranties contained herein shall not apply to any Panduit products that have been subjected to misuse, neglect, improper storage, handling, installation or accidental damage or modified or altered by persons other than Panduit or persons authorized by Panduit. In addition, the firmware warranty does not cover any defects resulting from Buyer-supplied firmware or unauthorized interfacing, operation outside of the environmental specifications for the products, or improper or inadequate site preparation or maintenance by Buyer. Panduit products are not designed, intended or authorized to be used in medical applications or as components in medical devices that are used to sustain or support human life. Should Buyer purchase or use a Panduit product for any such unintended or unauthorized medical application, Buyer shall indemnify and hold Panduit harmless from any liability or damage whatsoever arising out of the use of Panduit products in such medical applications.
- 6. LIMITATION ON LIABILITY. THE WARRANTIES PROVIDED HEREIN ARE BUYER’S SOLE AND EXCLUSIVE WARRANTIES. ALL IMPLIED WARRANTIES, INCLUDING WITHOUT LIMITATION THE IMPLIED WARRANTIES OF MERCHANTABILITY OR FITNESS FOR ANY PARTICULAR USE ARE DISCLAIMED. TO THE EXTENT PERMITTED BY LAW, IN NO EVENT SHALL PANDUIT BE LIABLE FOR ANY LOSS OR DAMAGES ARISING FROM ANY PANDUIT PRODUCT WHETHER DIRECT, INDIRECT, CONSEQUENTIAL, INCIDENTAL OR SPECIAL, INCLUDING WITHOUT LIMITATION ANY CLAIM FOR LOSS OF DATA, LOSS OF ACTUAL OR ANTICIPATED REVENUE, PROFITS OR SAVINGS.**
- 7. General.** This Limited Product Warranty applies to the Panduit products only and not to any combination or assembly of the Panduit products. Nothing in this Limited Product Warranty shall be construed to provide Buyer with a warranty for any system implementation using Panduit products. The Panduit Certification Plus System Warranty is available for projects that are installed by Panduit Certified Installers, meet various requirements and are registered with Panduit in accordance with the terms of the Panduit Certification Plus System Warranty.