



Product designation

SSF

Product type designation

RFID safety
sensor

General characteristics

General characteristics

Coding type

Teach-in

Switching distance

mm

10mm (X axis);
5mm (Y axis);
5mm (Z axis)

Contact characteristics

Type of contact

OSSD

Auxiliary supply

Nominal auxiliary voltage supply

24VDC

Operating range

V

19...28

Insulation voltage

kV

0.3

Input characteristics

Number of inputs

Nr.

2

Start/Restart inputs and EDM

nr.

1

Output characteristics

Number of safe OSSD outputs

nr.

2

Number of feedback outputs

Nr.

1

Output contacts ratings

300mA

Safety parameters

ISO 13849-1 security category

Cat. 4

ISO 13849-1 performance level

PLe

Mechanical features

Cable connection

M12 connector

Fixing

Both directions

Weight

g

44

Ambient conditions

Protection degree

IP67 and IP69K

Pollution degree

2

Temperature

Operating temperature

min

°C

-25

max

°C

+70

Storage temperature

min

°C

-25

max

°C

+70

Relative humidity

%

<90%

Dimensions

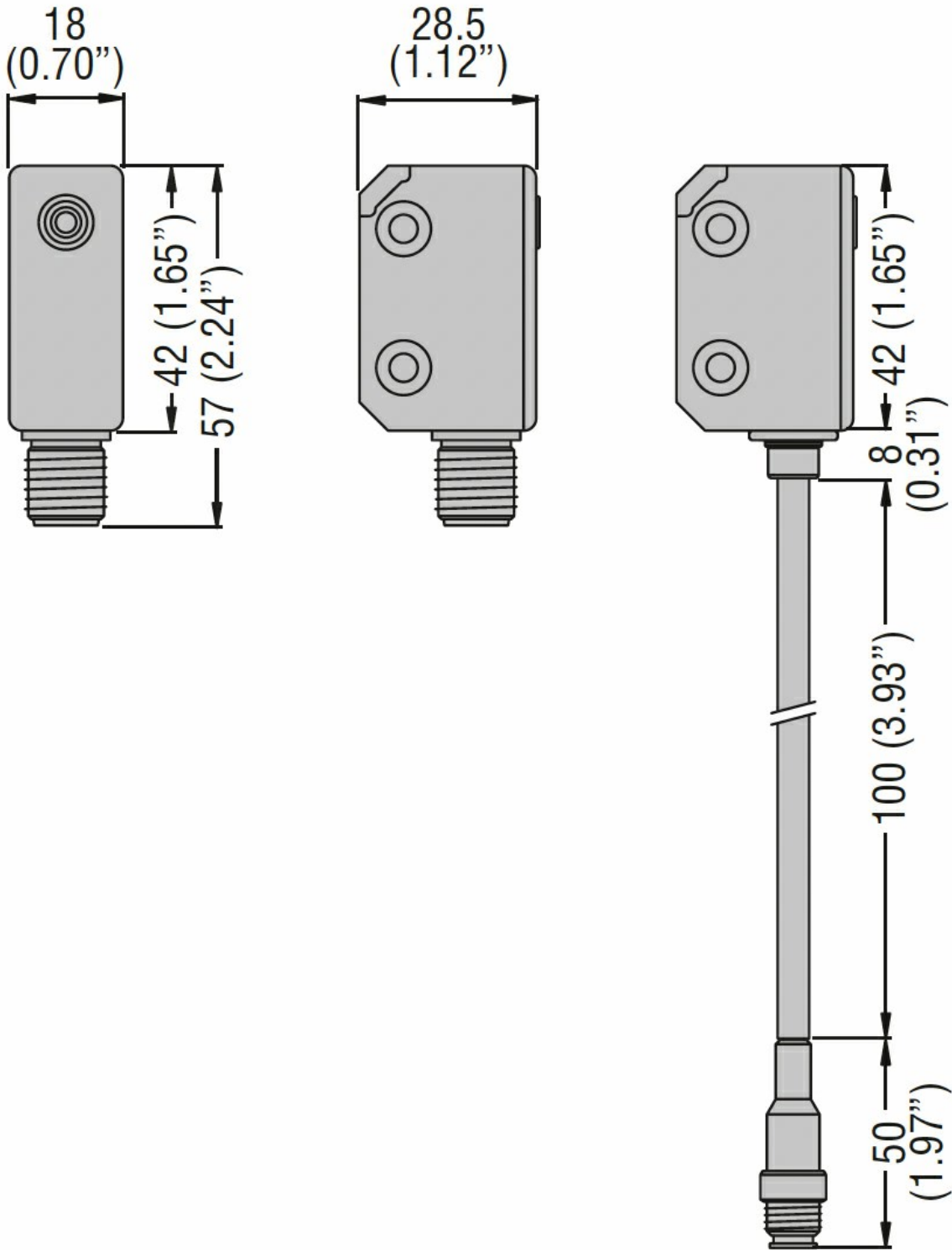

Wiring diagrams

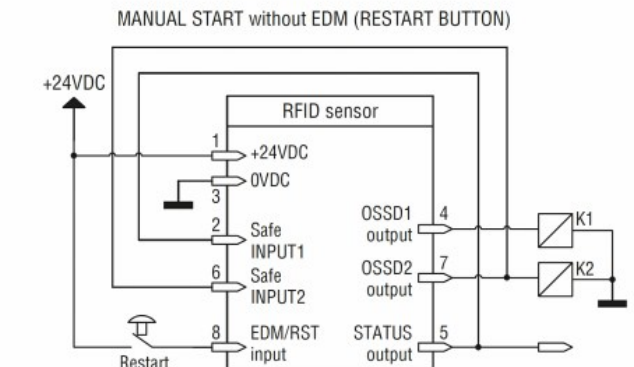
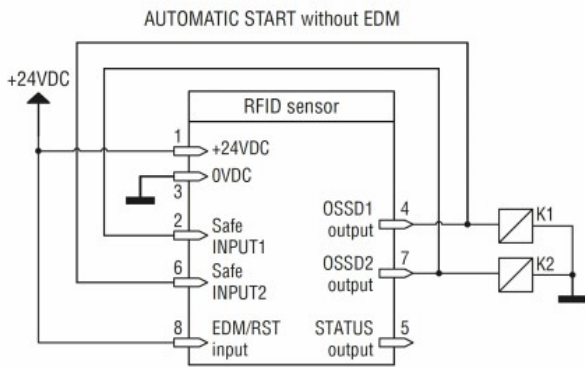
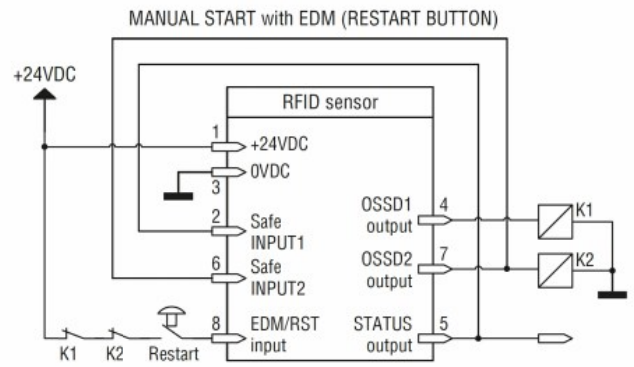
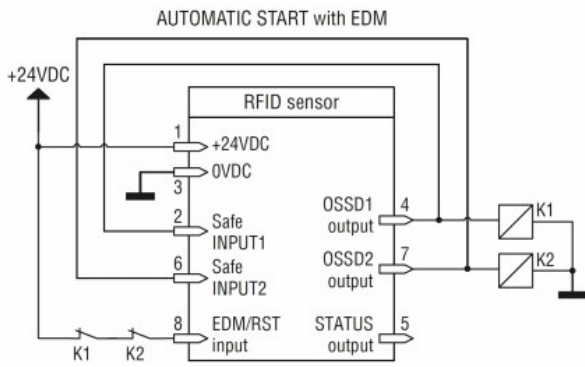

Certifications and compliance

Compliance

- Cat. 4
- EN/BS 61508-1(SIL 3)
- EN/BS 61508-2 (SIL 3)
- EN/BS 61508-3 (SIL3)
- IEC/BS 62061 (max. SIL 3).
- PLe according to EN/BS 13849-1

Certificates

- cULus
- TÜV

ETIM classification

ETIM 8.0

EC001449 -
Device for
monitoring of
safety-related
circuits