



ALKALINE BATTERY NX-POWER TECH

PILE ALCALINE NX-POWER TECH

MAIN INFORMATION / INFORMATIONS GÉNÉRALES

SIZE	FORMAT	LR1-N
BRAND	MARQUE	NX
TECHNOLOGY	TECHNOLOGIE	Alkaline / Alcaline
VOLTAGE	TENSION	1.5V
WEIGHT	POIDS	8.5 to 9.5gr
SHELF LIFE*	DURÉE DE VIE*	5 years / 5 ans
STORAGE TEMPERATURE RANGE	TEMPÉRATURE DE STOCKAGE	10°C to 25°C
TERMINALS	SORTIE	Flat / Plot pile
PACKING	CONDITIONNEMENT	Blister x1

*In consideration of typical loss of capacity at storage. *Dans les conditions normales de stockage.



DIMENSIONS / DIMENSIONS

A	29.1 to/à 30.2mm
Ø	10.9 to/à 12mm
C	7.2 to/à 7.8mm
F	3.3 to/à 3.7mm
G	0.9 to/à 1.3mm

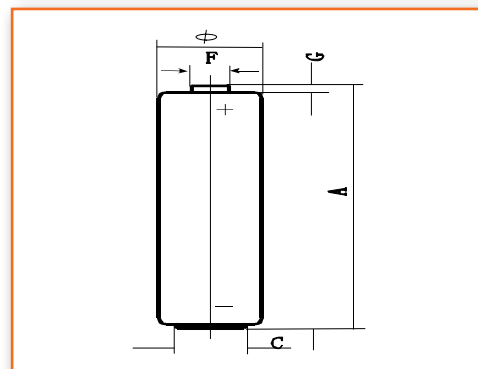

DISCHARGE DIAGRAM / COURBES DE DÉCHARGE

