

STIP W R

DEEL
PARTIE
TEIL
PART
PARTE
PARTE **A**

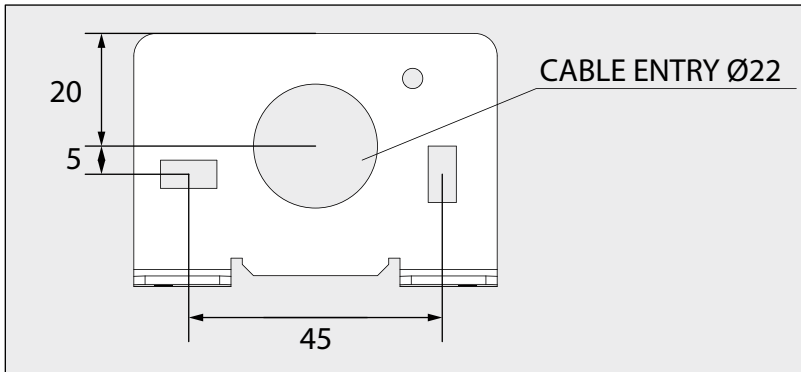
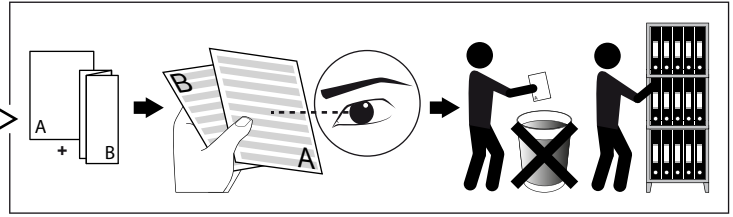

U	100-240V
P	4,1W

IP55

Beschermd tegen stof - Beschermd tegen waterstralen
 Protégé contre les poussières - Protégé contre les jets d'eau
 Staubgeschützt - Geschützt gegen Wasserstrahl
 Dust-protected - Protected against water jets
 Protegido contra el polvo - Protegido contra chorros de agua
 Protetto contro la polvere - Protetto contro i getti d'acqua

Goederen zijn dubbel geïsoleerd - geen aarding nodig
 Les produits ont une isolation double et ne peuvent pas être mis à la terre
 Güter sind doppelt isoliert und müssen nicht geerdet werden
 Goods have double insulation and must not be grounded
 Los productos tienen u aislamiento doble y no se pueden conectar a tierra
 I prodotti possiedono un doppio isolamento e non devono essere collegati a terra

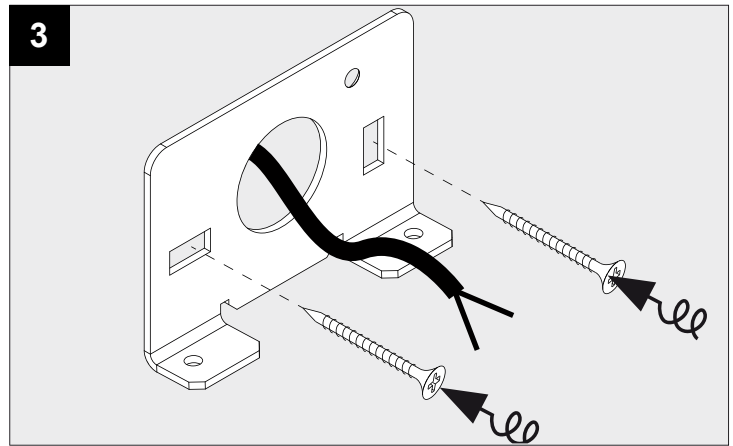
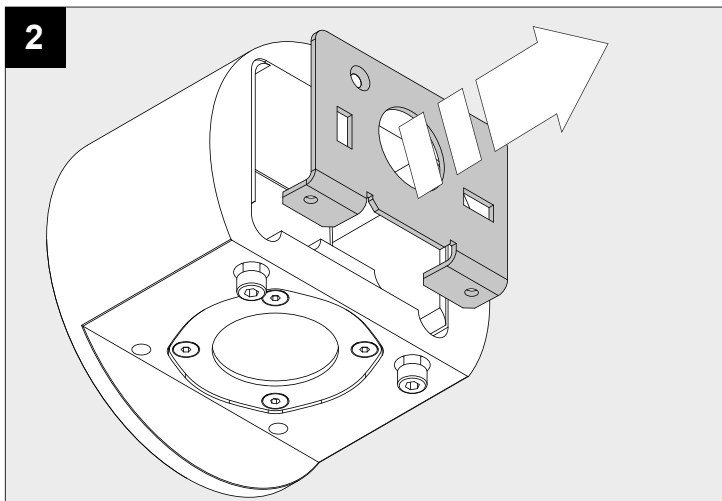
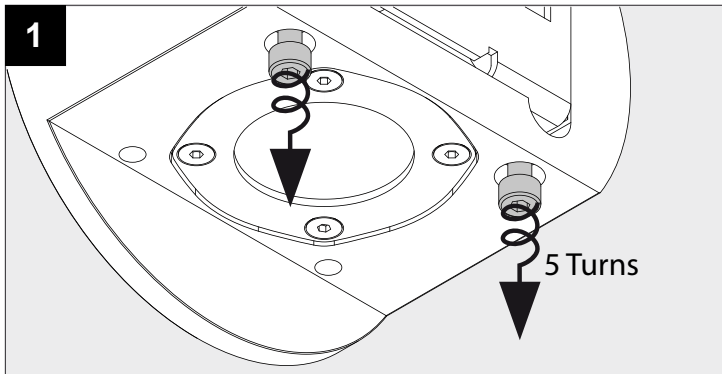

CAUTION! DO NOT PERFORATE THE PROTECTIVE COATING

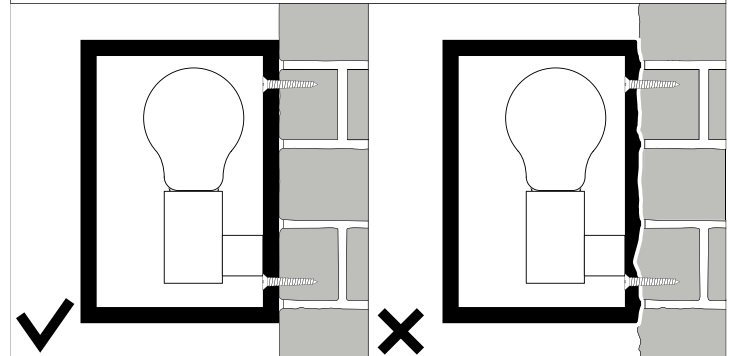

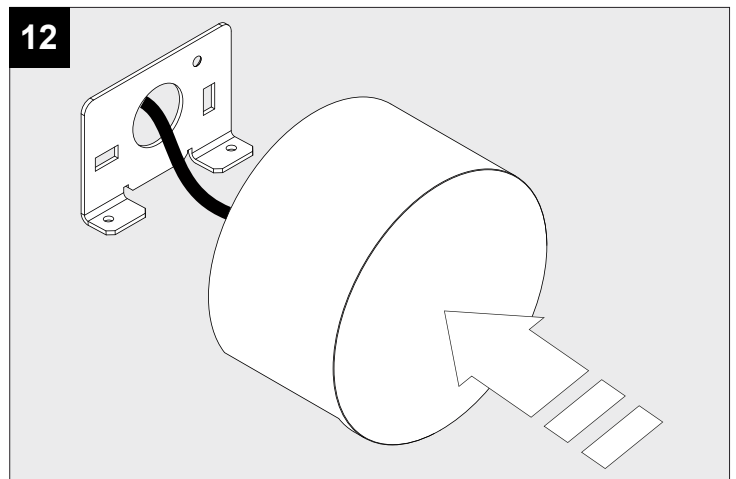
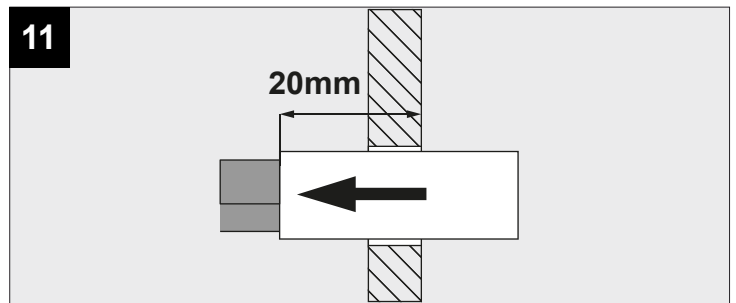
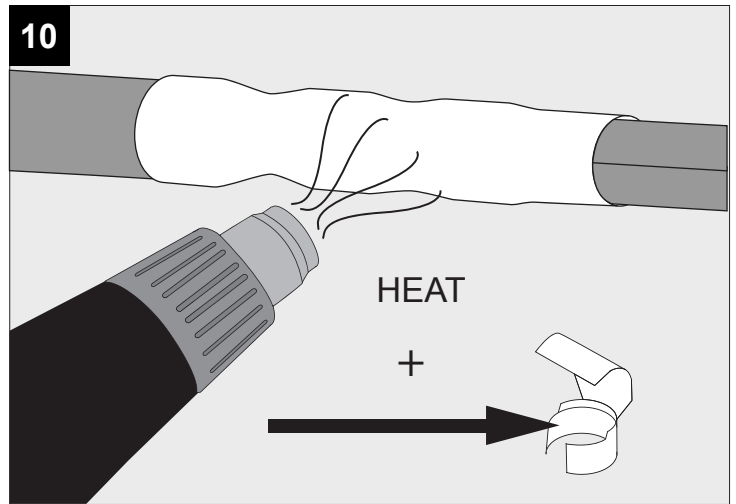
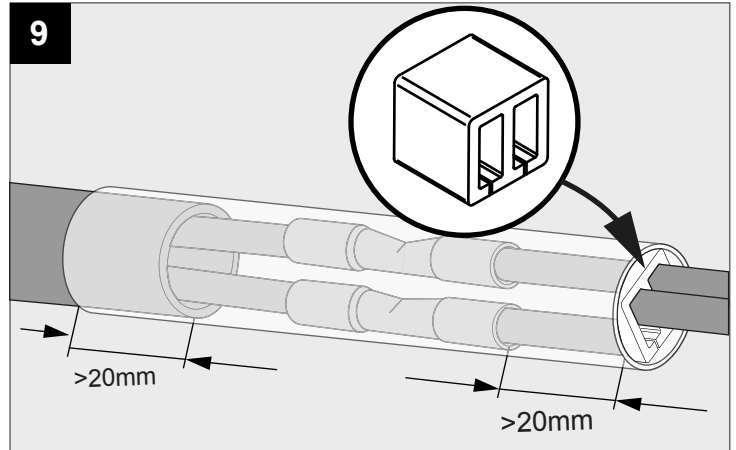
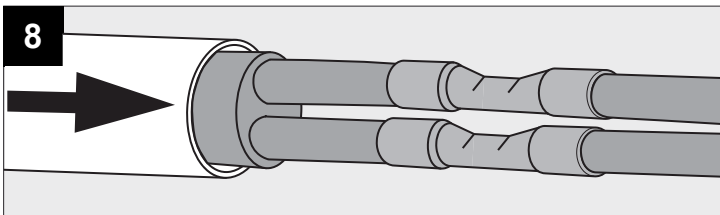
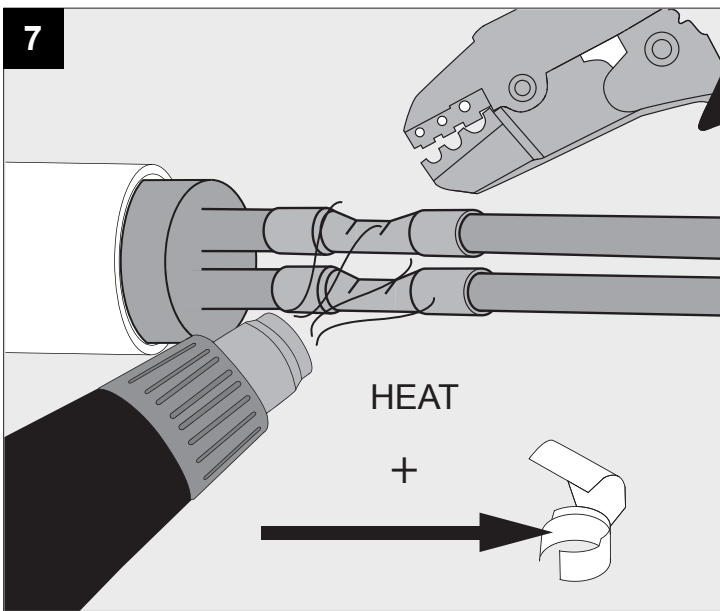
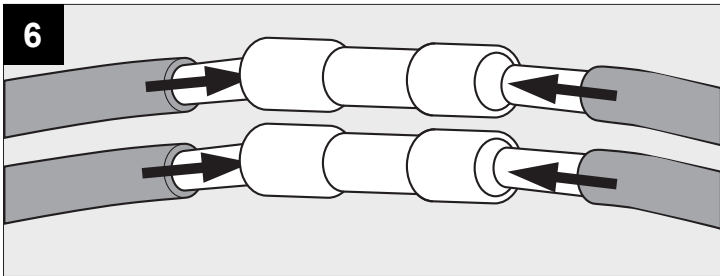
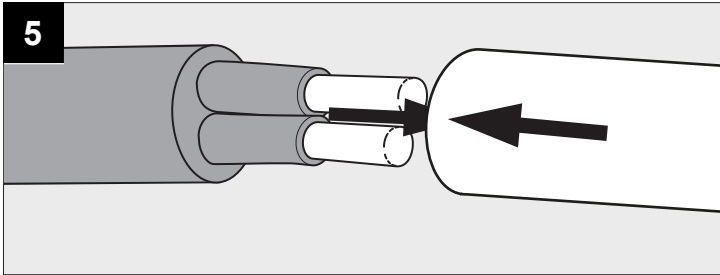
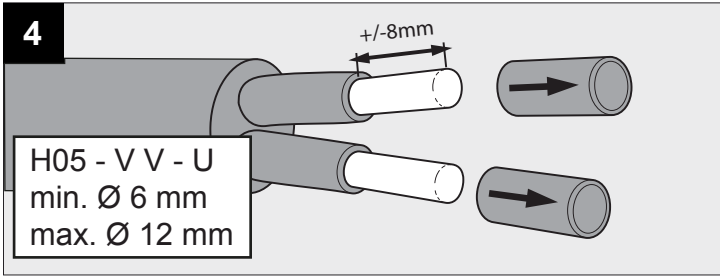

13

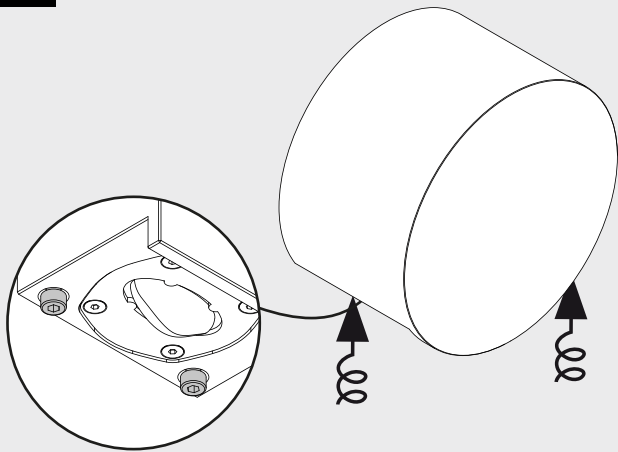

14

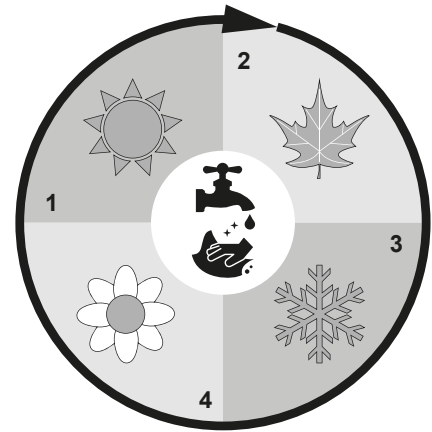
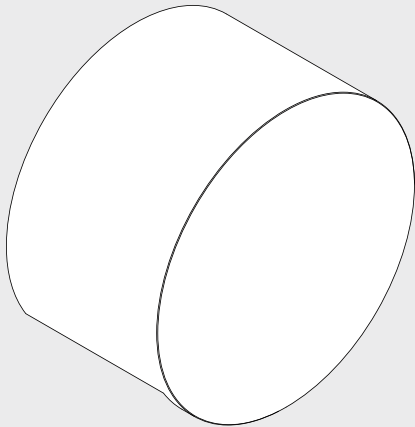

CAUTION! CLEAN AT LEAST QUATERLY WITH WATER AND NON-ABRASIVE CLOTH

De verlichtingsbron van dit verlichtingstoestel zal enkel door de fabrikant of door de fabrikant aangestelde installateur vervangen worden.

La source lumière de cet appareil ne sera remplacée que par l'entreprise ou par un agent reconnu.

Das enthaltene Leuchtmittel sollte nur durch entsprechendes Fachpersonal ersetzt werden.

The light source contained in this luminaire shall only be replaced by the manufacturer or his service agent.

La fuente de iluminación que tiene esta luminaria sólo puede remplazarse por el fabricante o por un instalador autorizado.

La sorgente luminosa incorporata in questo apparecchio può essere sostituita solo dal produt tore, da un suo centro assistenza oppure da una persona in possesso della necessaria abilitazione.

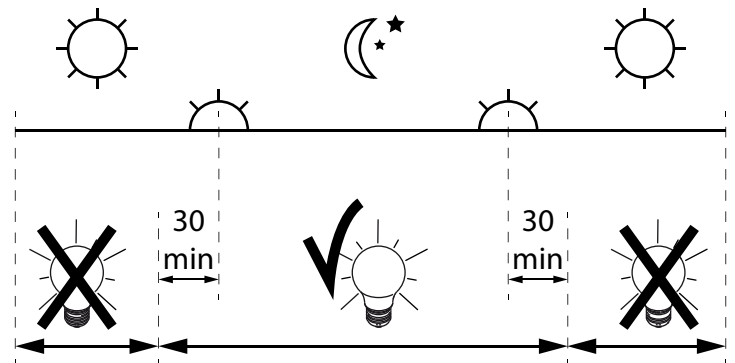

Dagelijkse ontstekingsperiode toegestaan
 Durée quotidienne d'allumage admissible
 Erlaubte tägliche einschaltdauer
 Allowed daily operation period
 Period giornaliero di accensione ammesso
 Periodo diario de encendido permitido