

1 Raccordement électrique Connect electrical wires

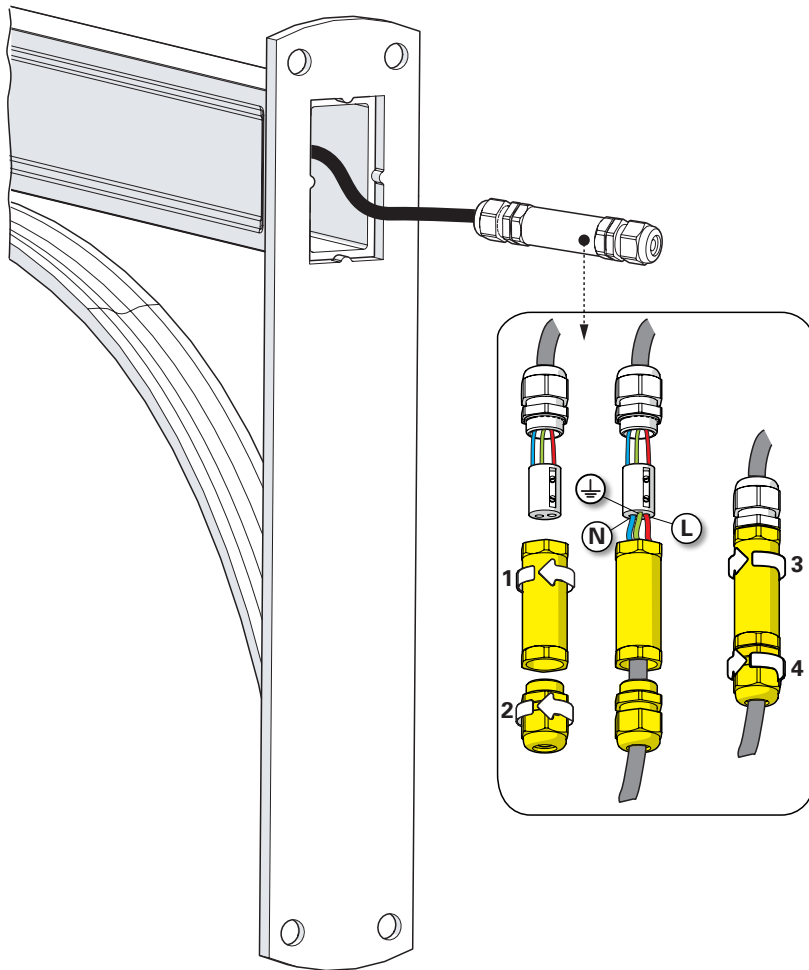

2 Fixation de la potence au mur Fix the bracket to the wall

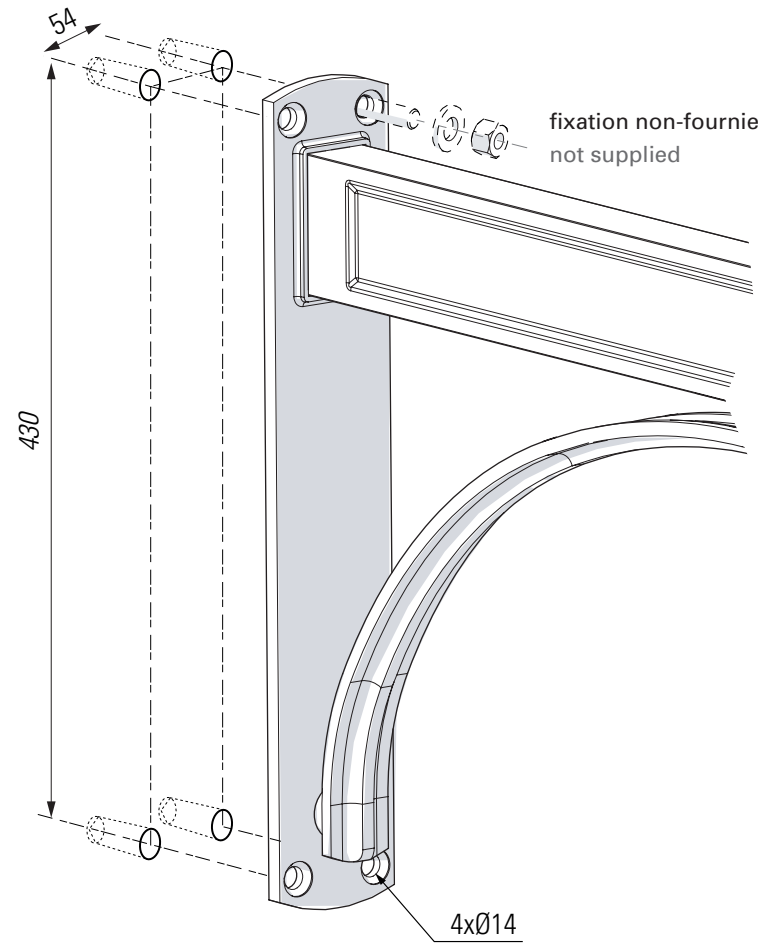

3 Extraire la verrine
Extract the glass

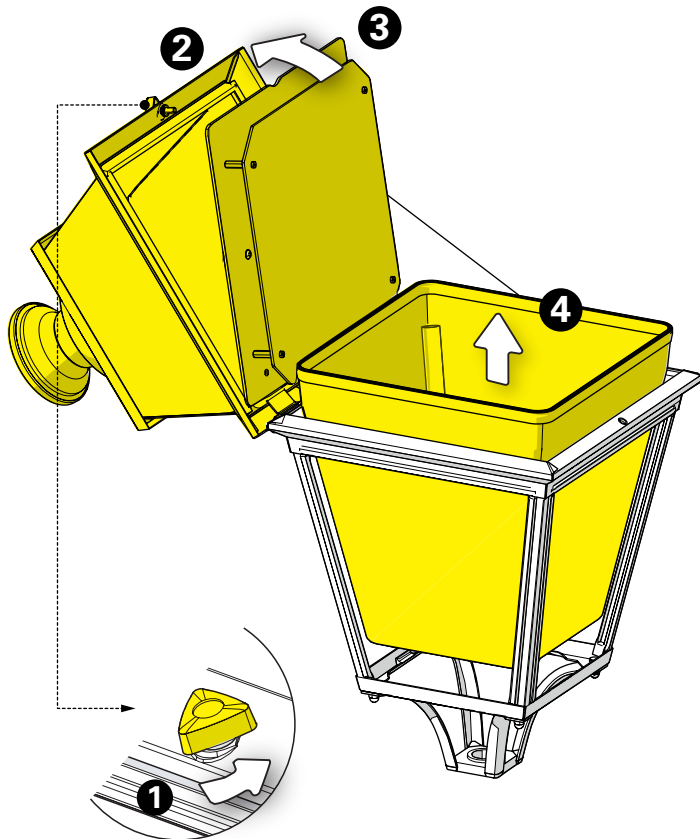

4 Montage de la tête sur la potence
Mount the luminaire head
on the bracket

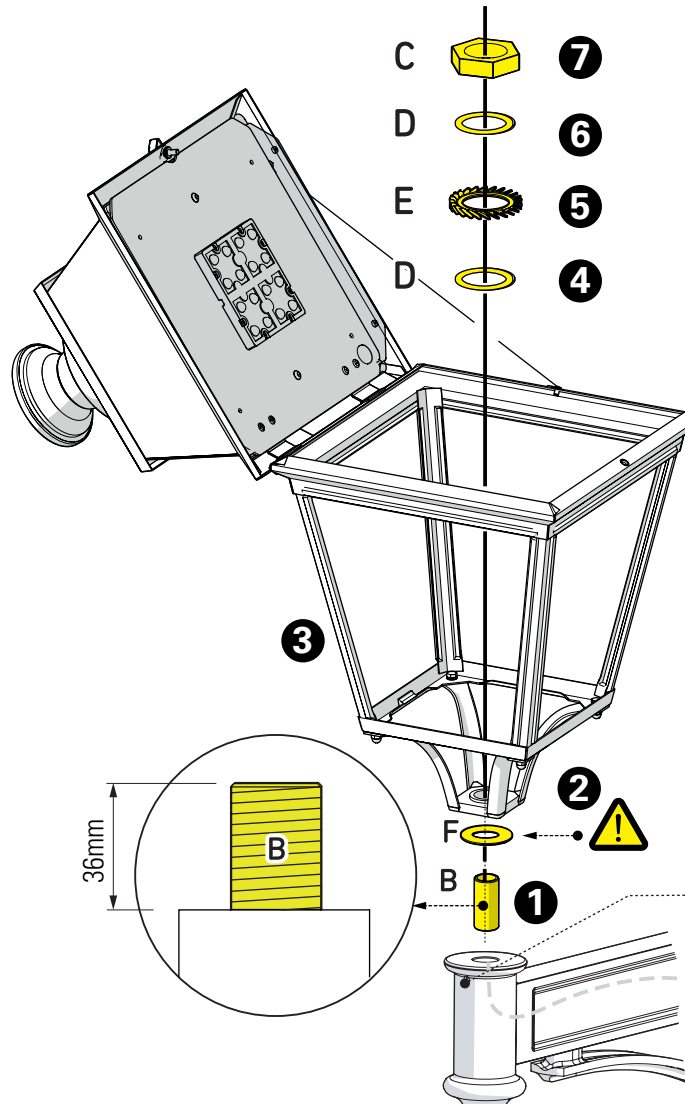

5 Montage du câble & du presse-étoupe
Mount the cable & cable-gland

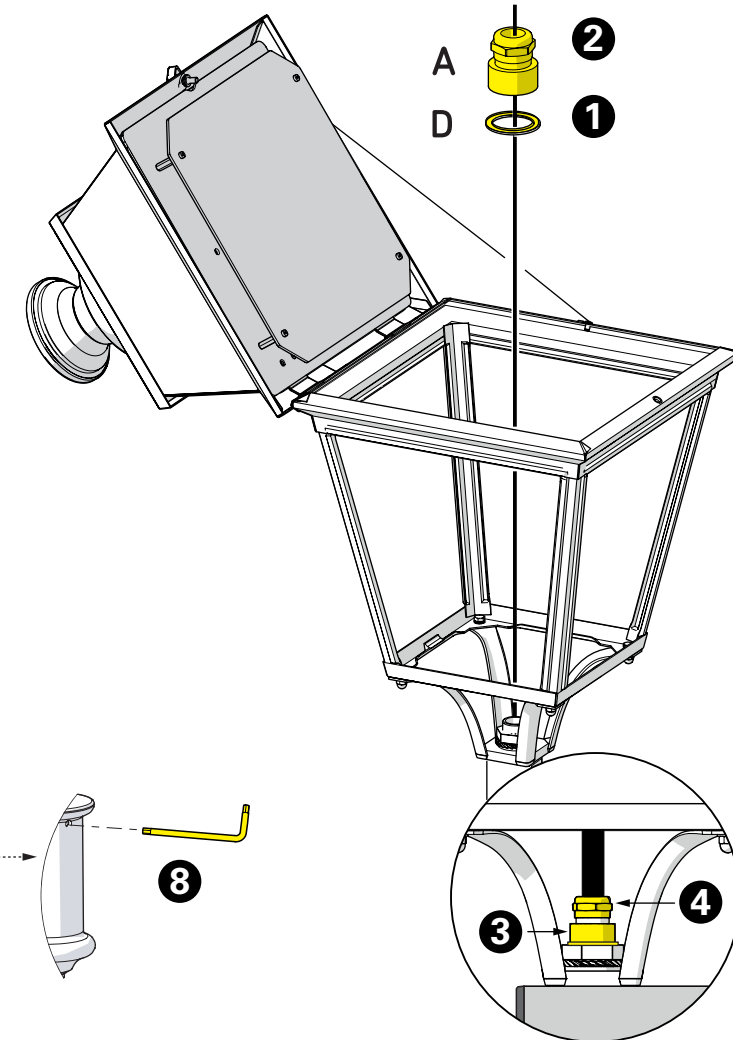

6 Montage de la verrine & passage du câble
Put in place the glass and insert cable into the conduit

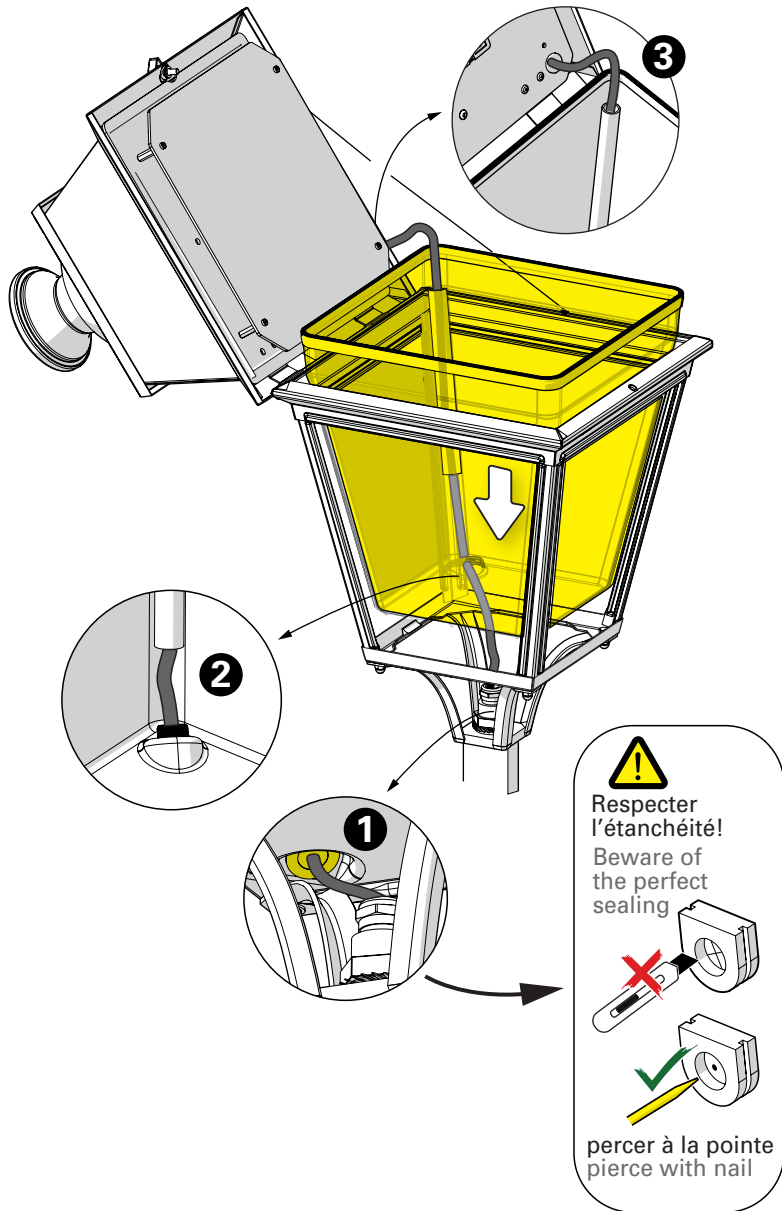

7 Raccordement électrique
Connect electrical wires

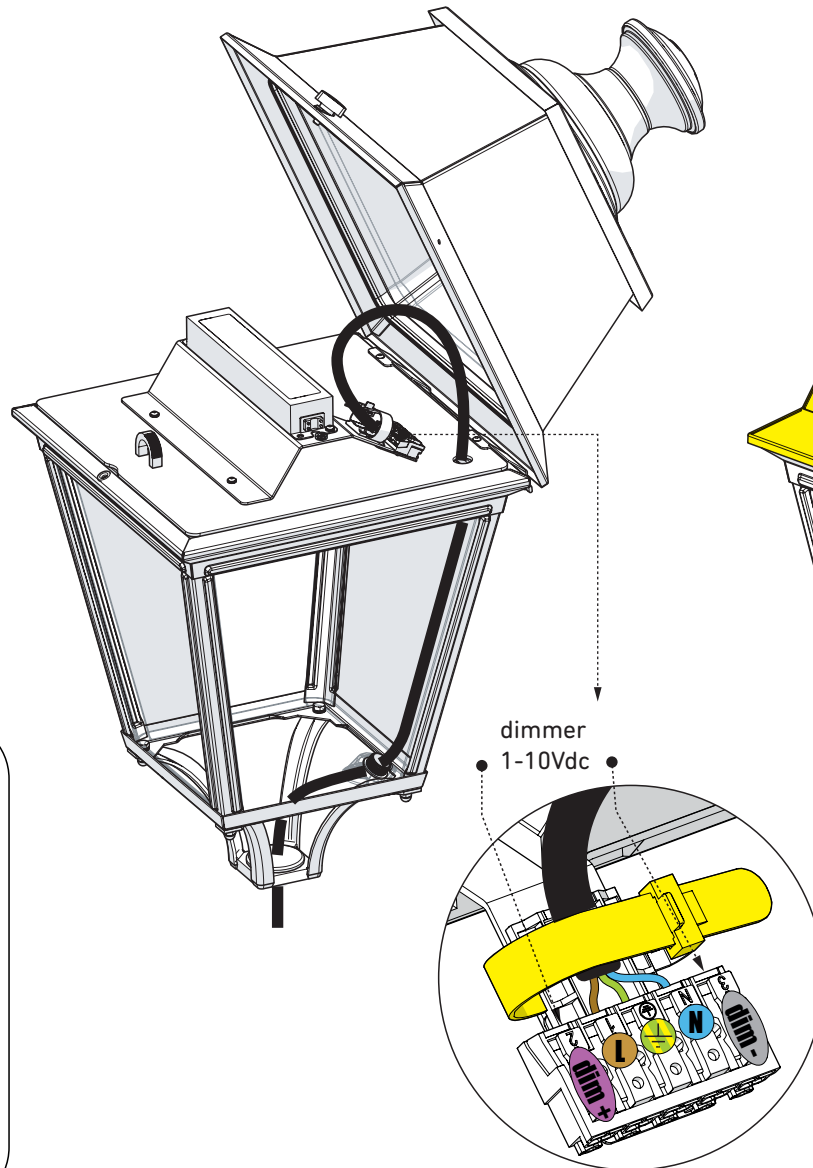

8 Fermeture de la lanterne
Close the luminaire head

