



# LL3-DC03

LL3

FIBERS

**SICK**  
Sensor Intelligence.



## Ordering information

Type	Part no.
LL3-DC03	5326020

Included in delivery: FC (1)

Other models and accessories → [www.sick.com/LL3](http://www.sick.com/LL3)

## Detailed technical data

## Features

<b>Device type</b>	Fibers
<b>Functional principle</b>	Proximity system
<b>For fiber-optic sensor</b>	GLL170(T), WLL180, WLL24 Ex, WLL80
<b>Fiber length</b>	4,000 mm
<b>Fiber material</b>	Polymethylmethacrylat (PMMA)
<b>Jacket material</b>	Polyethylen (PE)
<b>Fiber head material</b>	Acrylnitril-Butadien-Styrol (ABS)
<b>Outer diameter, fiber-optic cable connection</b>	2.2 mm
<b>Fiber-optic cable cuttable</b>	✓
<b>Fiber-optic head design</b>	Flat type
<b>Fiber arrangement</b>	Monofiber
<b>Core structure</b>	2 x Ø 1,5 mm Monofiber
<b>Angle of dispersion &lt; 60°</b>	Yes
<b>Compatibility with infrared light (1,450 nm)</b>	No
<b>Application</b>	Lcd / clear material / semiconductor, Limited sensing range
<b>Highly flexible/elastic fibers (bend radius 1–4 mm)</b>	No
<b>Adapter end sleeves required</b>	No
<b>Angle of dispersion</b>	14.81°
<b>Integrated lens</b>	Yes
<b>Minimal object diameter</b>	0.3 mm <sup>1)</sup>
<b>Included with delivery</b>	FC fiber cutter (5304141)
<b>Compatibility tip adapters</b>	No

<sup>1)</sup> Minimum detectable object was determined at optimum measuring distance and optimum setting.

## Mechanics/electronics

<b>Bend radius, fibre-optic cable</b>	25 mm
<b>Ambient operating temperature</b>	-40 °C ... +60 °C

## Classifications

<b>ECLASS 5.0</b>	27270905
<b>ECLASS 5.1.4</b>	27270905

<b>ECLASS 6.0</b>	27270905
<b>ECLASS 6.2</b>	27270905
<b>ECLASS 7.0</b>	27270905
<b>ECLASS 8.0</b>	27270905
<b>ECLASS 8.1</b>	27270905
<b>ECLASS 9.0</b>	27270905
<b>ECLASS 10.0</b>	27270905
<b>ECLASS 11.0</b>	27270905
<b>ECLASS 12.0</b>	27270905
<b>ETIM 5.0</b>	EC002651
<b>ETIM 6.0</b>	EC002651
<b>ETIM 7.0</b>	EC002651
<b>ETIM 8.0</b>	EC002651
<b>UNSPSC 16.0901</b>	39121528

## Sensing ranges with WLL80

<b>Operating mode 16 <math>\mu</math>s</b>	10.1 mm ... 95 mm
<b>Operating mode 70 <math>\mu</math>s</b>	9.6 mm ... 174 mm
<b>Operating mode 250 <math>\mu</math>s</b>	0 mm ... 236 mm
<b>Operating mode 500 <math>\mu</math>s</b>	0 mm ... 270 mm
<b>Operating mode 1 ms</b>	0 mm ... 294 mm
<b>Operating mode 2 ms</b>	0 mm ... 372 mm
<b>Operating mode 8 ms</b>	0 mm ... 447 mm

## Sensing ranges with WLL180T

<b>Operating mode 16 <math>\mu</math>s</b>	12 mm ... 60 mm
<b>Operating mode 70 <math>\mu</math>s</b>	10 mm ... 75 mm
<b>Operating mode 250 <math>\mu</math>s</b>	5 mm ... 85 mm
<b>Operating mode 2 ms</b>	3 mm ... 150 mm
<b>Operating mode 8 ms</b>	2 mm ... 280 mm
<b>Note</b>	Sensing ranges related to fiber-optic sensors with type of light: visible red light

## Sensing ranges with GLL170

<b>Operating mode 250 <math>\mu</math>s</b>	11 mm ... 48 mm
---	-----------------

## Sensing ranges with GLL170T

<b>Operating mode 50 <math>\mu</math>s</b>	17 mm ... 48 mm
<b>Operating mode 250 <math>\mu</math>s</b>	7.5 mm ... 64 mm

### Dimensional drawing (Dimensions in mm (inch))

LL3-DC03

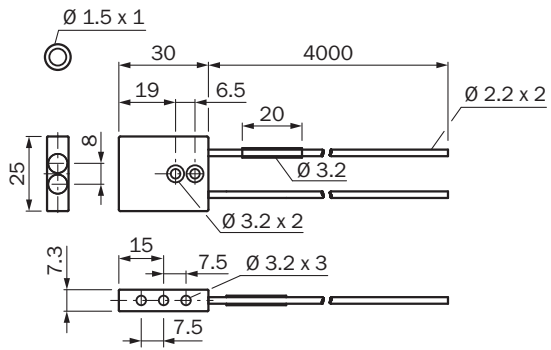

## SICK AT A GLANCE

SICK is one of the leading manufacturers of intelligent sensors and sensor solutions for industrial applications. A unique range of products and services creates the perfect basis for controlling processes securely and efficiently, protecting individuals from accidents and preventing damage to the environment.

We have extensive experience in a wide range of industries and understand their processes and requirements. With intelligent sensors, we can deliver exactly what our customers need. In application centers in Europe, Asia and North America, system solutions are tested and optimized in accordance with customer specifications. All this makes us a reliable supplier and development partner.

Comprehensive services complete our offering: SICK LifeTime Services provide support throughout the machine life cycle and ensure safety and productivity.

For us, that is “Sensor Intelligence.”

## WORLDWIDE PRESENCE:

Contacts and other locations –[www.sick.com](http://www.sick.com)