

THIS COPY IS PROVIDED ON A RESTRICTED BASIS AND IS NOT TO BE USED IN ANY WAY DETRIMENTAL TO THE INTERESTS OF PANDUIT CORP.

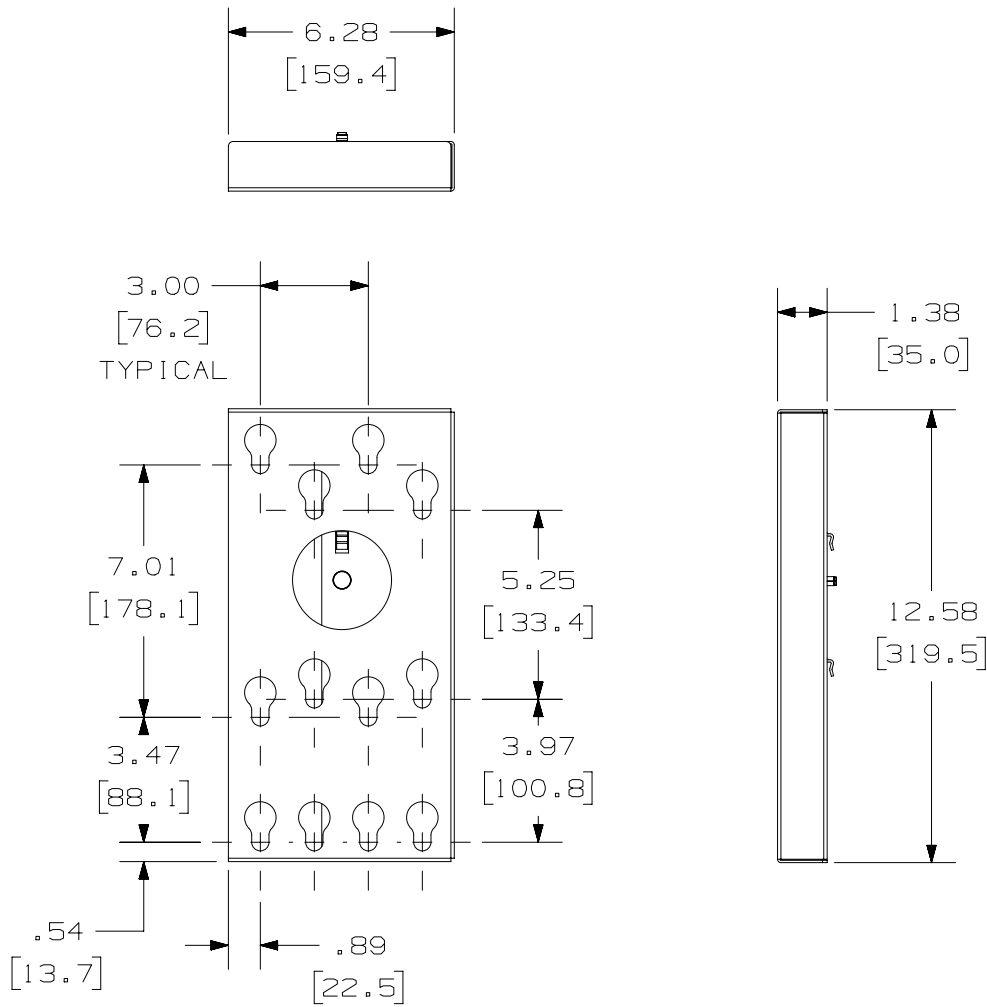

- NOTES:
1. VISIT OUR ON-LINE CATALOG AT WWW.PANDUIT.COM FOR A LIST OF CURRENT PARTS APPLICABLE FOR USE WITH THIS PRODUCT.
 2. DIMENSIONS IN [] ARE METRIC.
 3. ALL MATERIALS AND COMPONENTS USED MEET THE MATERIAL RESTRICTIONS OF RoHS (EUROPEAN DIRECTIVE 2011/65/EU ON THE RESTRICTION OF HAZARDOUS SUBSTANCES) AS PROPOSED BY THE RoHS TECHNICAL ADAPTATION COMMITTEE.
 4. WEIGHT: 5 LB [2.27 Kg]
 5. PART INCLUDES:
2 - PDU MOUNTING BRACKETS

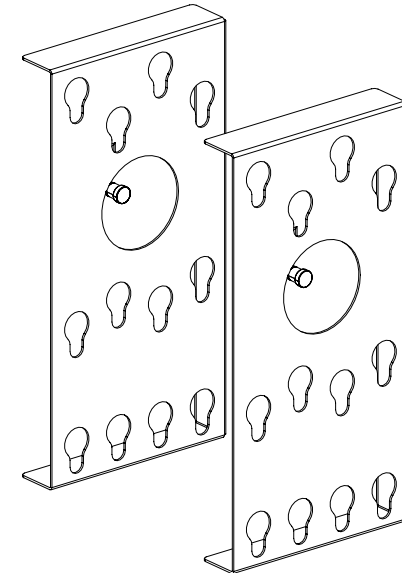
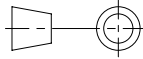

| | | | | |
|---|---------|----------------------------|------|----------------|
| PART NUMBER | | PR2VPDUB | | |
| TITLE | | PR2V TOOL-LESS PDU BRACKET | | |
| | | CUSTOMER DRAWING | | |
| ITEM REVISION NAME | | 00475EBB/05 | | |
| DATASET FILE NAME | | 00475EBB_DC/05A | | |
|  | | THIRD ANGLE PROJECTION | | |
| MATERIAL | | STEEL | | DRAWING NUMBER |
| | | | | 00475EBB-DC |
| REV | DATE | BY | CHK | APR |
| 05A | 4-23-20 | TWV | MDJR | JEFK |
| RELEASED TO PRODUCTION | | | | |
| DESCRIPTION | | | | |
| ECN | | | | |
| DRAWN BY | | DATE | CHK | SCALE |
| TWV | | 4-23-20 | MDJR | 1:4 |
| SHEET 1 OF 1 | | | | SIZE |
| | | | | A |

A-SIZE CUSTOMER

2

1

2

1