

SHAPE AND DIMENSION

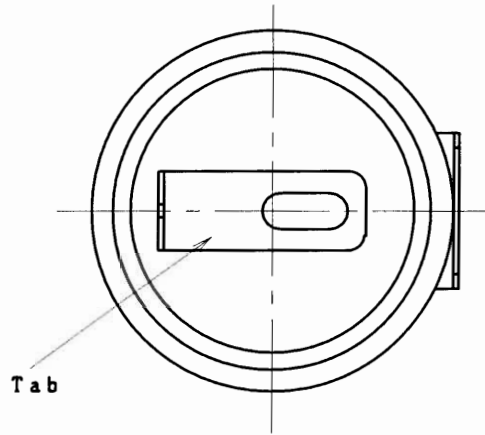

Tab

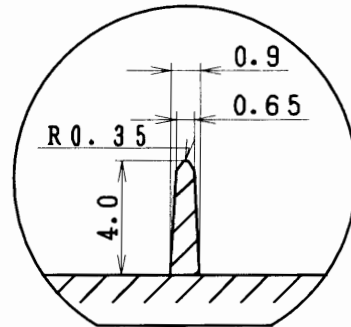

Magnification of Figure A

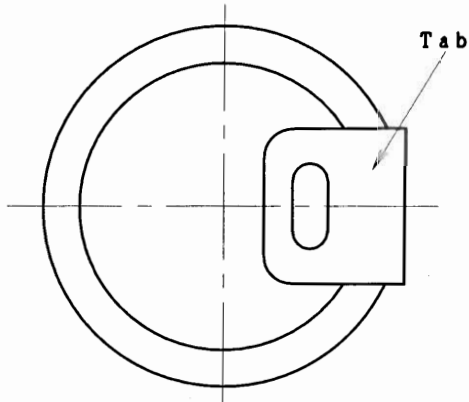
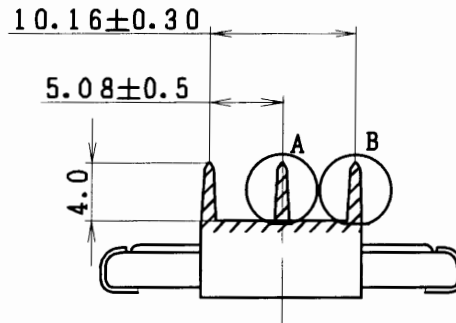
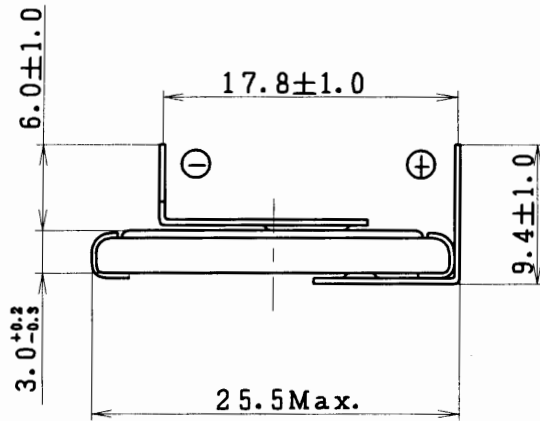

Tab

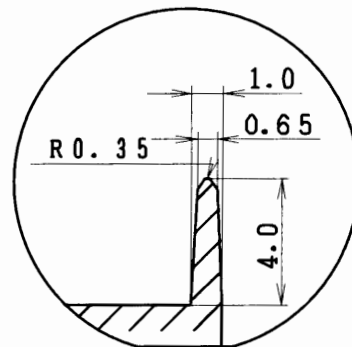

Magnification of Figure B

TAB MATERIAL : STAINLESS STEEL WITH PLATING

TAB THICKNESS: 0.2mm

WELDING STRENGTH OF TAB: MIN. 19.6N

(VERTICAL DIRECTION FROM WELDING PLATE)

Unit: mm

Model code	ML2430-HS1 166153202	SANYO Electric Co., Ltd. Mobile Energy Company Ion Technology Business Unit
---------------	-------------------------	--