

THIS COPY IS PROVIDED ON A RESTRICTED BASIS AND IS NOT TO BE USED IN ANY WAY DETRIMENTAL TO THE INTERESTS OF PANDUIT CORP.

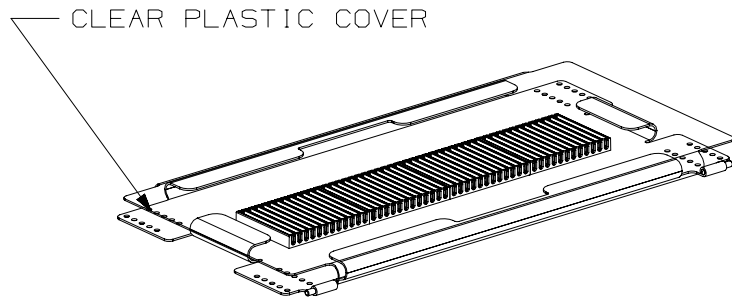

NOTES:

1. VISIT OUR ON-LINE CATALOG AT WWW.PANDUIT.COM FOR A LIST OF CURRENT PARTS APPLICABLE FOR USE WITH THIS PRODUCT.
2. DIMENSIONS IN [] ARE METRIC.
3. TRAY WILL HOLD UP TO 48 FUSION SPLICES.
4. INCLUDED WITH SPLICE TRAY;
 - 1 CLEAR PLASTIC COVER.
 - 4 FUSION SPLICE HOLDERS.
 - 2 GROMMET SLEEVES.
 - 10 CABLE TIES.
 - 6" HEAT SHRINK TUBING.
5. ALL MATERIALS AND COMPONENTS USED MEET THE MATERIAL RESTRICTIONS OF RoHS (EUROPEAN DIRECTIVE 2011/65/EU ON THE RESTRICTION OF HAZARDOUS SUBSTANCES) AS PROPOSED BY THE RoHS TECHNICAL ADAPTATION COMMITTEE.

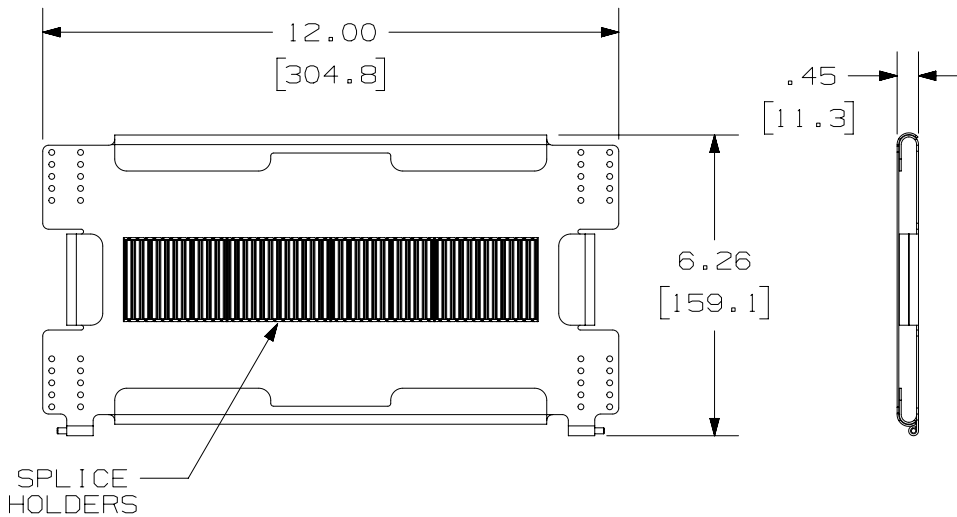

PANDUIT P/N	WEIGHT
FST48	0.52 LBS (240g)

PART NUMBER		FST48		
TITLE		SPLICE TRAY UNIT 48 FUSION SPLICES CUSTOMER DRAWING		
ITEM REVISION NAME		17F088AX/01		
DATASET FILE NAME		17F088AX_DC/01A		
		THIRD ANGLE PROJECTION		
MATERIAL		DRAWING NUMBER 17F088AX-DC		
00A	09-28-18	SAT	BONS	AW
REV	DATE	BY	CHK	APR
INITIAL RELEASE				17F088AX-DC
DESCRIPTION				ECN
SAT				09-27-18
BONS				NONE
SHEET 1 OF 1				A

A-SIZE CUSTOMER