

Installation Instructions for Appleton™ Wireless Motion Sensor

FOR PROPER AND SAFE INSTALLATION OF THIS PRODUCT, PLEASE READ THE FOLLOWING INSTRUCTIONS.

Wireless Hardware Revision	1
HART® Device Revision	1
Device Install Kit/DD Revision	Device Revision 01, DD Revision 01 or greater

Product Safety

Signal Words Defined

DANGER indicates a hazardous situation which, if not avoided, will result in death or serious injury. **WARNING** indicates a hazardous situation which, if not avoided, could result in death or serious injury. **CAUTION** indicates a hazardous situation which, if not avoided, could result in minor or moderate injury. **NOTICE** is used to address practices not related to physical injury.

Safety Instructions

WARNING

Instructions and procedures in this section may require special precautions to ensure the safety of the personnel performing the operations. Information that potentially raises safety issues is indicated by a warning symbol () . Refer to the following safety messages before performing an operation preceded by this symbol.

- Failure to follow these installation guidelines could result in death or serious injury.
- Ensure only qualified personnel perform the installation.
- Explosions could result in death or serious injury.
- Installation of this transmitter in an explosive environment must be in accordance with the appropriate local, national, and international standards, codes, and practices. Review the approvals section of this manual for any restrictions associated with a safe installation.
- Before connecting a Field Communicator in an explosive atmosphere, ensure the instruments are installed in accordance with intrinsically safe or non-incendive field wiring practices.
- Verify that the operating environment of the device is consistent with the appropriate hazardous locations certifications.
- Process leaks may cause harm or result in death.
- Electrical shock could cause death or serious injury.
- Avoid contact with the leads and terminals. High voltage that may be present on leads can cause electrical shock.
- This device complies with Part 15 of the FCC Rules. Operation is subject to the following conditions:
 - This device may not cause harmful interference.
 - This device must accept any interference received, including interference that may cause undesired operation.
 - This device must be installed to ensure a minimum antenna separation distance of 8-in. (20 cm) from all persons.
- The power module may be replaced in a hazardous area. The power module has surface resistivity greater than one gigaohm and must be properly installed in the wireless device enclosure. Care must be taken during transportation to and from the point of installation to prevent electrostatic charge build-up.

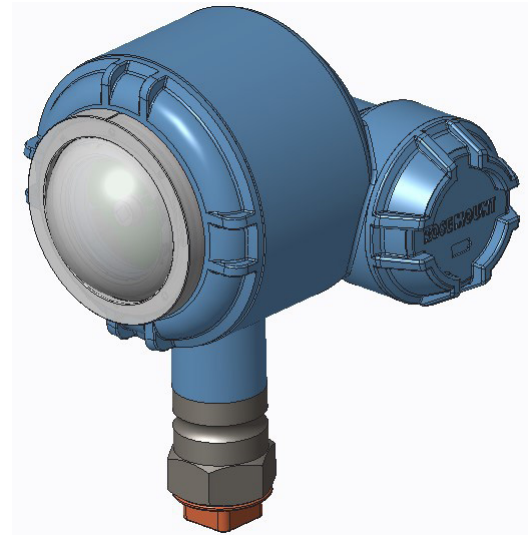

⚠ CAUTION:

- Use caution when handling the power module, as it may be damaged if dropped from heights in excess of 20 feet.

⚠ NOTICE:

- Before installing the wireless transmitters, the Appleton Motion Sensor and all other wireless devices should be installed only after the Wireless Gateway has been installed and is functioning properly. Wireless devices should also be powered up in order of proximity from the Wireless Gateway, beginning with the closest. This will result in a simpler and faster network installation.
- Shipping considerations for wireless products (lithium batteries: Green Power Module, model number 701PGNKF):
 - The unit was shipped to you without the power module installed. Remove the power module prior to shipping.
 - Each Green Power Module contains one “D” size primary lithium-thionyl chloride battery. Primary lithium batteries are regulated in transportation by the U. S. Department of Transportation and are also covered by IATA (International Air Transport Association), ICAO (International Civil Aviation Organization), and ARD (European Ground Transportation of Dangerous Goods). It is the responsibility of the shipper to ensure compliance with these or any other local requirements. Consult current regulations and requirements before shipping.
- Power Module Considerations (Green Power Module, model number 701PGNKF):
 - The Green Power Module with the wireless unit contains one “D” size primary lithium-thionyl chloride battery (model number 701PGNKF). Each battery contains approximately 5.0 grams of lithium. Under normal conditions, the battery materials are self-contained and are not reactive as long as the batteries and the pack integrity are maintained. Care should be taken to prevent thermal, electrical or mechanical damage. Contacts should be protected to prevent premature discharge.
 - Battery hazards remain when cells are discharged.
 - Power modules should be stored in a clean and dry area. For maximum battery life, storage temperature should not exceed 86 °F (30 °C).

1 Introduction

1.1 Using this manual

The sections in this manual provide information on installing, operating, and maintaining the Appleton Motion Sensor with WirelessHART® protocol. The sections are organized as follows:

- Configuration provides instruction on commissioning and operating Rosemount 248 Wireless Transmitters. Information on software functions, configuration parameters, and online variables is also included.
- Installation contains mechanical and electrical installation instructions.
- Commissioning contains techniques for properly commissioning the device.
- Operation and maintenance contain operation and maintenance techniques.
- Alert Message Mapping contains important alerts in the HART® command 48 additional status field for the transmitter.

1.2 Product recycling/disposal

Recycling of equipment and packaging should be taken into consideration and disposed of in accordance with local and national legislation/regulations.

1.3 Applications/Intended Use

- Suitable for wet locations; apply a corrosion-inhibiting grease, such as petroleum or soap-thickened mineral oils, in 3 lines, spaced approximately 120 degrees apart, perpendicular to the threads. Tighten all unused close-up plugs.
- Non-hazardous locations where severe weather conditions, excessive moisture, dirt, dust, corrosive atmospheres, and high ambient temperatures are encountered.
- Suitable for indoor/outdoor applications.
- Product senses motion, ambient light as well as temperature and reports to the control system over WirelessHART.

1.4 Specifications

- Type 3R, 4, 4X
- IP66
- Ambient temperature - 40°C to +65°C
- Battery operated at 3.6V
- 0–99 percent non-condensing relative humidity
- Suitable up to altitude of 2000m
- Suitable for use in Wet Locations
- Corrosive environments
- Refer to product nameplate for details.

1.5 Agency Ratings

- Ex ia IIC Ga
- Class I Div 1 Group A B C D
- Class I Div 2 Group A B C D
- Temperature Classification:

Ambient Temperature	IECEx Ex ia IIC	Class I Div 1 GRP A B C D	Class I Zone 0 IIC
40°C	T5	T5	T5
55°C	T5	T5	T5
65°C	T4	T4	T4

2 Configuration

2.1 Overview

This section contains information on configuration and verification that should be performed prior to installation.

Field Communicator and AMS Device Manager instructions are given to perform configuration functions.

2.2 Bench top configuration

Bench top configuration consists of testing the transmitter and verifying transmitter configuration data. The device must be configured before installation, which may be performed either directly or remotely. Direct configuration can be performed using a Field Communicator, AMS Device Manager, AMS Wireless Configurator, or any WirelessHART® Communicator. Remote configuration can be performed using AMS Device Manager, AMS Wireless Configurator, or the Wireless Gateway.

The power module must be installed to provide power to the Appleton Motion Sensor for configuration. To communicate to the transmitter, begin by removing the power module cover. This will expose the HART® communication terminals located on the Green Power Module. Next, connect the Field Communicator leads to the COMM port connections on the Green Power Module.

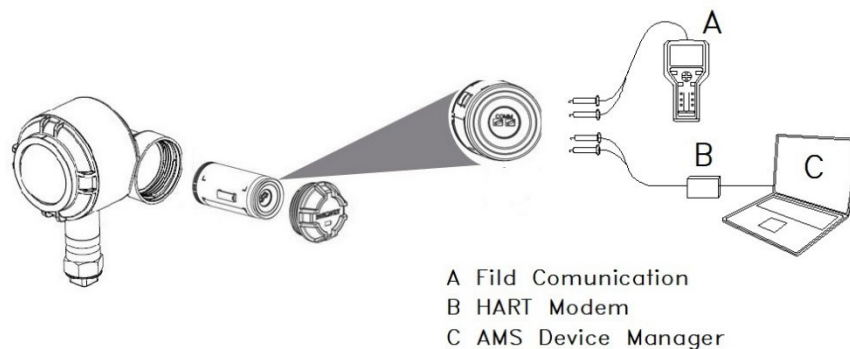

FIGURE 2-1: FIELD COMMUNICATOR CONNECTIONS

Field Communicator

The power module must be installed in the device for the Field Communicator to interface with the transmitter. The Field Communicator connections are located on the Green Power Module. To communicate to the transmitter, begin by removing the power module cover. This will expose the HART® communication terminals located on the Green Power Module. Next, connect the Field Communicator leads to the COMM port connections on the Green Power Module.

This transmitter uses the Green Power Module; order model number 701PGNKF. The power module is keyed and can only be inserted in one orientation. Field communication with this device requires a HART-based Field Communicator.

AMS Device Manager and AMS Wireless Configurator

When configuring product using AMS Device Manager or AMS Wireless Configurator, double click the Appleton Motion Sensor device icon (or right click and select Con/Setup), then select the Configure Menu. AMS configuration changes are implemented when the Apply button is clicked.

During direct connection configuration, AMS Device Manager will search for a HART- compatible device and indicate when the connection is made. If AMS Device Manager fails to connect, it indicates that no device was found.

Emerson Wireless Gateway

The Appleton Motion Sensor supports limited remote configuration through the Wireless Gateway. The Gateway allows configuration of the following device parameters: HART Tag, Short Tag, Descriptor, Engineering Units, Update Rate etc.

Default settings

The Appleton Motion Sensor default configuration is shown below:

Area/Zone/Group	255
Latched Motion Timeout	5 minutes
Network ID	Factory-generated network parameters
Join Key	Factory-generated network parameters
Update Rate	5 minutes

2.3 Device network configuration

Join to network

In order to communicate with the Wireless Gateway, and ultimately the Host System, the transmitter must be configured to communicate over the wireless network. This step is the wireless equivalent of connecting wires from a transmitter to the host system.

Procedure

1. From the Home screen, select 2: Configure.
2. Select 1: Guided Setup.
3. Select 2: Join to Network.

Using a Field Communicator or AMS Device Manager to communicate with the transmitter, enter the Network ID and Join Key so they match the Network ID and Join Key of the Wireless Gateway and the other devices in the network. If the Network ID and Join Key are not identical to those set in the Gateway, the transmitter will not communicate with the network. The Network ID and Join Key may be obtained from the Wireless Gateway on the Setup → Network → Settings page on the web server.

Configure update rate

The Update Rate is the frequency at which a new measurement is taken and transmitted over the wireless network. This may be changed at commissioning, or at any time via AMS Device Manager. The update rate is user selectable from 1 second to 60 minutes.

Procedure

1. From the Home screen, select 2: Configure.
2. Select 1: Guided Setup.
3. Select 3: Configure Update Rate.

When the device configuration is completed, remove the power module and replace the module cover. The power module should be inserted only when the device is ready to be commissioned. Use caution when handling the power module.

3 Installation

3.1 Safety messages

Instructions and procedures in this section may require special precautions to ensure the safety of the personnel performing the operations. Information that potentially raises safety issues is indicated by a warning symbol (⚠). Refer to the following safety messages before performing an operation preceded by this symbol.

⚠ WARNING

- Failure to follow these installation guidelines could result in death or serious injury.
- Ensure only qualified personnel perform the installation.
- Explosions could result in death or serious injury.
- Installation of this transmitter in an explosive environment must be in accordance with the appropriate local, national, and international standards, codes, and practices. Review the approvals section of this manual for any restrictions associated with a safe installation.
- Before connecting a Field Communicator in an explosive atmosphere, ensure the instruments are installed in accordance with intrinsically safe or non-incendive field wiring practices.

- Verify that the operating environment of the device is consistent with the appropriate hazardous locations certifications.
- Process leaks may cause harm or result in death.
- Electrical shock could cause death or serious injury.
- Avoid contact with the leads and terminals. High voltage that may be present on leads can cause electrical shock.
- This device complies with Part 15 of the FCC Rules. Operation is subject to the following conditions:
- This device may not cause harmful interference.
- This device must accept any interference received, including interference that may cause undesired operation.
- This device must be installed to ensure a minimum antenna separation distance of 8-in. (20 cm) from all persons.
- The power module may be replaced in a hazardous area. The power module has surface resistivity greater than one gigaohm and must be properly installed in the wireless device enclosure. Care must be taken during transportation to and from the point of installation to prevent electrostatic charge build-up.

3.3.1 Mechanical

Location

When choosing an installation location and position, take into account the need for access to the mesh network, access to the transmitter and to the power module compartment for ease of power module replacement.

Electronics cover

The electronics cover is tightened so that polymer contacts polymer. When removing the electronics cover, ensure that there is no damage done to the O-ring. If damaged replace with a O-ring before reattaching cover, ensuring polymer contacts polymer (i.e. no O-ring visible).

3.3.2 Electrical

Power module

The transmitter is self-powered. The power module contains a primary lithium-thionyl chloride battery (Green Power Module, model number 701PGNKF). Each battery contains approximately 5 grams of lithium. Under normal conditions, the battery materials are self-contained and are not reactive as long as the battery and the power module are maintained. Care should be taken to prevent thermal, electrical, or mechanical damage. Contacts should be protected to prevent premature discharge.

⚠ CAUTION

- Use caution when handling the power module, it may be damaged if dropped from heights in excess of 20 feet.
- Battery hazards remain when cells are discharged.
- Power modules should be stored in a clean and dry area. For maximum power module life, storage temperature should not exceed 30 °C.

3.3.3 Assembly Instructions

Procedure

1. Remove the transmitter power module cover.
2. Connect the Green Power Module.
3. Reattach and tighten the power module cover.
4. Always ensure a proper seal by installing the electronics housing cover(s) so that polymer contacts polymer (i.e., no O-ring visible).
5. Dimensions are in inches [millimeters].

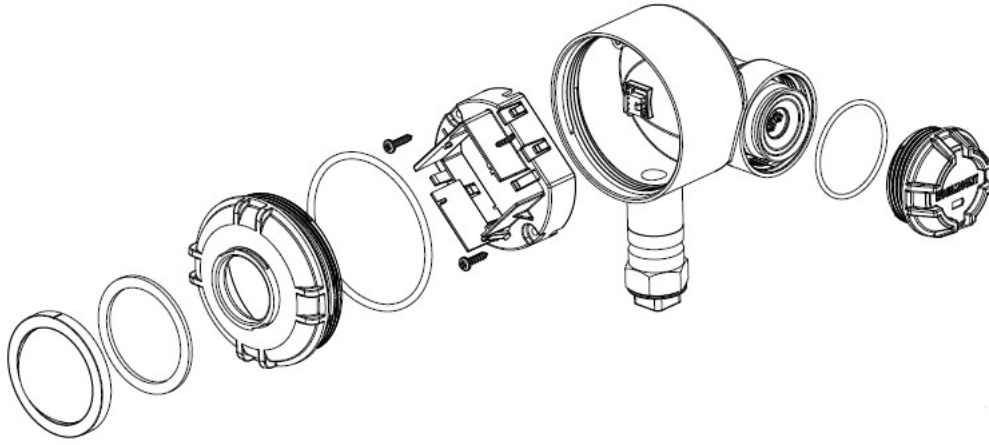

FIGURE 3-1: EXPLODED VIEW OF PRODUCT ASSEMBLY

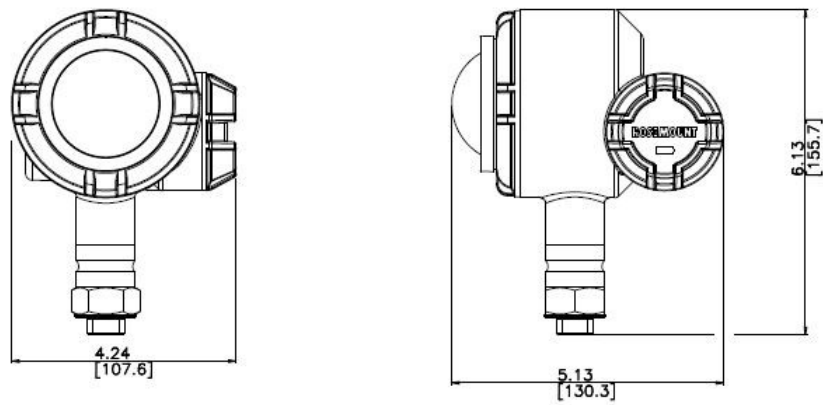

FIGURE 3-2: PRODUCT DIMENSIONS

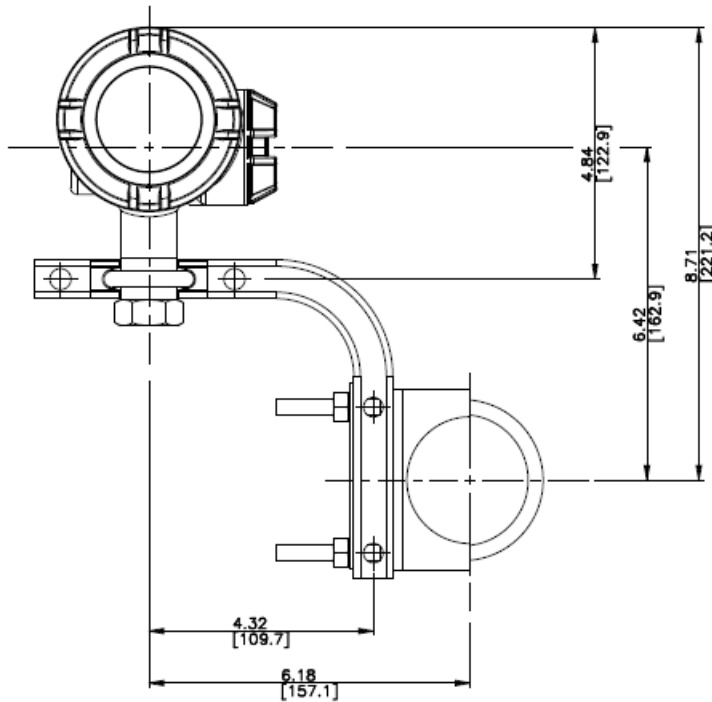

FIGURE 3-3: MOUNTING ASSEMBLY - DIMENSIONS ARE IN INCHES [MILLIMETERS]

4 Commissioning

Note:

The Appleton Motion Sensor and all other wireless devices should be installed only after the Wireless Gateway has been installed and is functioning properly. Wireless devices should also be powered up in order of proximity from the Wireless Gateway, beginning with the closest device to the Gateway. This will result in a simpler and faster network installation.

4.1 Verify operations

Operations can be verified in below locations:

- Using the Field Communicator
- At the Gateway's integrated web interface
- Using AMS Wireless Configurator or AMS Device Manager
- Using the Connecting Lighting Application

4.2.1 Emerson Wireless Gateway

In the integrated web interface from the Gateway, navigate to the Explorer → Status page. This page shows whether the device has joined the network and if it is communicating properly.

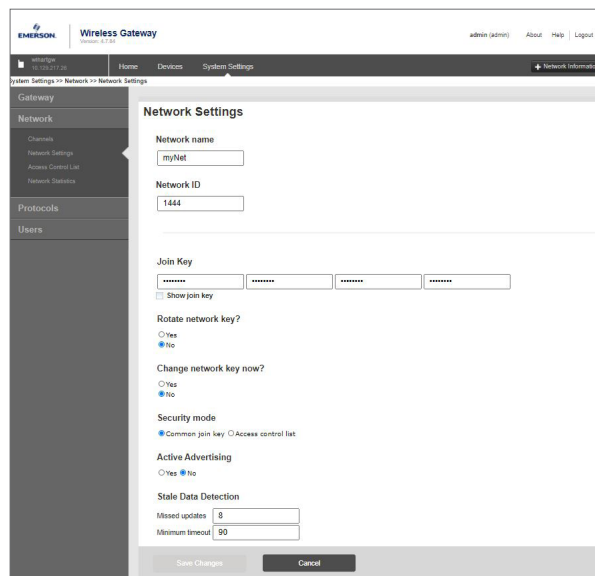

FIGURE 4-1: WIRELESS GATEWAY NETWORK SETTINGS

4.2.2 AMS Wireless Configurator

When the device has joined the network, it will appear in the Wireless Configurator window as illustrated in figure below. For HART® communication, a Appleton Motion Sensor DD is required.

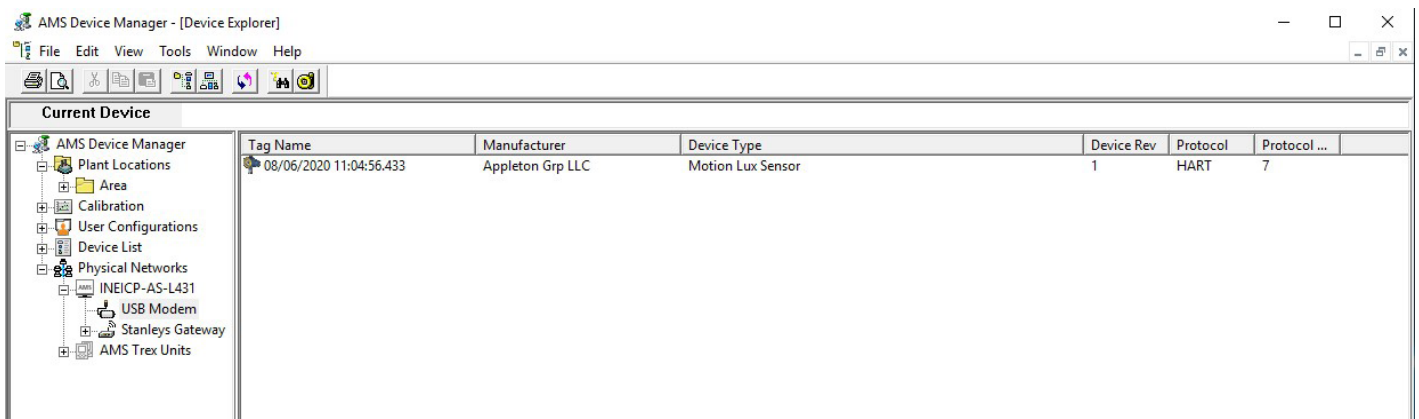

FIGURE 4-2: AMS WIRELESS CONFIGURATOR

5 Operation and Maintenance

5.1 Power module replacement

Expected power module life is 10 years at reference conditions. (1)

⚠ CAUTION:

DANGER OF EXPLOSION IF BATTERY IS INCORRECTLY REPLACED. REPLACE ONLY WITH THE SAME OR EQUIVALENT TYPE.

⚠ ATTENTION:

RISQUE D'EXPLOSION SI LA PILE N'EST PAS REMPLACÉ CORRECTEMENT. REMPLACER UNIQUEMENT PAR UNE PILE DE TYPE IDENTIQUE OU ÉQUIVALENT

When power module replacement is required, remove the cover and remove the Green Power Module. Replace the Green Power Module (part number 701PGNKF) and replace the cover. Tighten to specification and verify operation.

(1) Reference conditions are 70° F (21° C), transmit rate of once per minute, and routing data for three additional network devices.

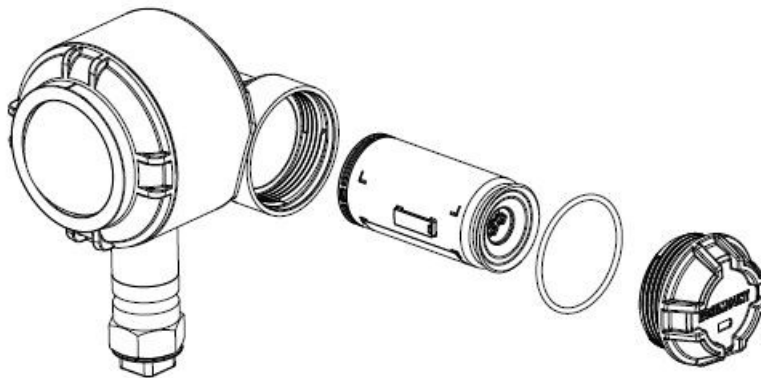

FIGURE 5-1: EXPLODED POWER MODULE VIEW

5.2 Handling Considerations

The Green Power Module with the wireless unit contains one “D” size primary lithium- thionyl chloride battery (Green Power Module, model number 701PGNKF). Each battery contains approximately 5.0 grams of lithium. Under normal conditions, the battery materials are self-contained and are not reactive as long as the batteries and the pack integrity are maintained. Care should be taken to prevent thermal, electrical or mechanical damage.

Contacts should be protected to prevent premature discharge.

Note:

Power modules should be stored in a clean and dry area. For maximum power module life, storage temperature should not exceed 86 °F (30 °C).

⚠ CAUTION:

Use caution when handling the power module, it may be damaged if dropped from heights in excess of 20 feet.

⚠ WARNING

Battery hazards remain when cells are discharged.

5.3 Environmental considerations

As with any battery, local environmental rules and regulations should be consulted for proper management of spent batteries. If no specific requirements exist, recycling through a qualified recycler is encouraged. Consult the material’s safety data sheet for battery specific information.

5.4 Shipping considerations

The unit was shipped to you without the power module installed. Remove the power module prior to shipping the unit.

Appendices

Appendix A Alert Message Mapping

This appendix outlines the most important alerts in the HART® command 48 Additional Status Field for the transmitter. The information in this section can be used by DeltaV™ for alert monitoring, and in the Emerson Wireless Gateway for Additional Status mapping in Modbus®, OPC, etc.

A complete list of additional status bits is available in the Wireless Gateway.

Table B-1 displays the device variable and variable mapping indexes for the transmitter.

Tables B-2 through B-4 show a list of the most important alert messages that may be displayed in the AMS Wireless Configurator and Field Communication together with the location of the Alert in the HART command 48 additional status field.

To view Active Alerts, from the Home screen, go to Service Tools → Active Alerts.

Table B-1: Device Variable Index

Device variable	Index
0	Supply voltage
1	Electronics temperature
2	Latched Motion
3	Ambient Lux

Table B-2: Failure Alerts (F:)

Message	Additional status (1)	Description
Critical Power Failure	Byte 6:: Bit 2	The supply voltage is too low and will affect device operation.
Electronics Defect	Byte 8:: Bit 6	An electronics error that could impact the device measurement reading has occurred.
Radio Failure	Byte 12:: Bit 4	The wireless radio has detected a failure or stopped communicating.

(1) Location of the Alert in the HART command 48 Status field.

Table B-3: Maintenance Alerts (M:)

Message	Additional status (1)	Description
Environmental Conditions Out of Range	Byte 8:: Bit 5	The device is outside its normal environmental operating conditions which may affect accuracy and/or proper operation.
Power Supply Conditions Out of Range	Byte 8:: Bit 4	The supply voltage is low and may affect device operation.

(1) Location of the Alert in the HART command 48 Status field.

Table B-4: Advisory Alerts (M:)

Message	Additional status (1)	Description
Capacity Denied	Byte 12:: Bit 0	The device has failed to require all of the necessary wireless bandwidth to broadcast at the configured rate(s)
Database Storage Error	Byte 0:: Bit 2	The device has failed to write to the database memory at some time in the past. Any data written during this time may have been lost
Configuration Alert	Byte 2:: Bit 6	The device has detected a configuration error
Electronics Temperature Exceeded	Byte 5:: Bit 0	The temperature recorded by the sensor on the sensor module exceeded the configured limit
Device Variable Simulation Active	Byte 8:: Bit 0	The device is in simulation mode and is not reporting actual information

(1) Location of the Alert in the HART command 48 Status field.

Appendix B Network Design Best Practices

B.1 Overview

All recommended practices should be followed to ensure highest data reliability. Deviation from these best practices may require device repeaters in the network to maintain 99 percent data reliability. The following are guidelines to achieve the best possible wireless network.

- Each wireless network field should be scoped to a single process unit.
- Minimize the number of hops to the Gateway in order to reduce latency. A minimum of five wireless instruments should be within effective range of the Emerson Wireless Gateway.
- Each device in the network should have at minimum three devices with potential communication paths. A mesh network gets its reliability from multiple communication pathways. Ensuring each device has multiple neighbors within range will result in the most reliable network.
- Have 25 percent of wireless instruments in the network within range of Emerson Wireless Gateway. Other enhancing modifications include creating a higher percentage of devices within effective range of the gateway to 35 percent or more. This clusters more devices around the gateway and ensures fewer hops and more bandwidth available to WirelessHART® devices with fast scan rates.
- Effective range is determined by type of process unit and the density of the infrastructure that surrounds the network.

B.2 Effective range

Heavy Obstruction: 100 ft. (30 m). Typical heavy density plant environment. Cannot drive a truck or equipment through.

Medium Obstruction: 250 ft. (76 m). Typical light process areas, lots of space between equipment and infrastructure.

Light Obstruction: 500 ft. (152 m). Typical of tank farms. Despite tanks being big obstructions themselves, lots of space between and above makes for good RF propagation.

Line of Sight: 750 ft. (230 m). No obstructions between WirelessHART® devices and devices mounted a minimum of 6 ft. (2 m) above ground or obstructions.

For examples and complete explanations, refer to the [IEC62591 WirelessHART System Engineering Guide](#).

Appendix C Accessories

Contact your local Emerson sales representative to purchase/replace these parts.

Item Description	Model number
Battery (Green Power Module)	701PGNKF
Mounting Bracket	00249-2612-0001
Lens Cover Kit (includes): <ul style="list-style-type: none">• Fresnel Lens (Type C)• Fresnel Lens Gasket• O-Ring Cover gasket	TBD

Appendix D Field Communicator Menu Tree

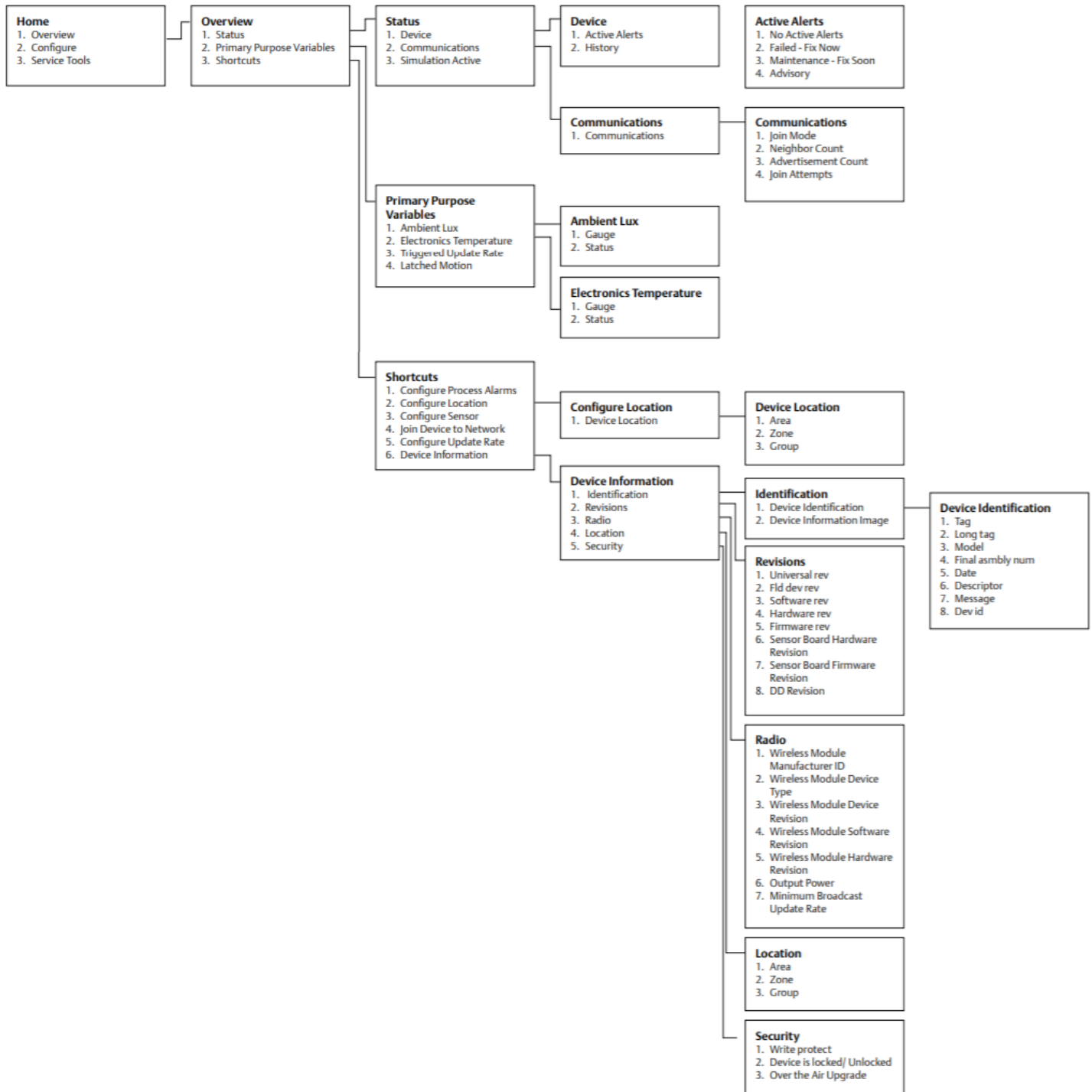

Except as expressly provided by Appleton Grp, LLC (Appleton), Appleton products are intended for ultimate purchase by industrial users and for operation by persons trained and experienced in the use and maintenance of this equipment and not for consumers or consumer use. Appleton warranties DO NOT extend to, and no reseller is authorized to extend Appleton's warranties to any consumer. While every precaution has been taken to ensure accuracy and completeness in this manual, Appleton Grp, LLC, assumes no responsibility, and disclaims all liability for damages resulting from use of this information or for any errors or omissions. Specifications are subject to change without notice. The Appleton and Emerson logos are registered in the U.S. Patent and Trademark Office. All other product or service names are the property of their registered owners. ©2020 Appleton Grp, LLC. All rights reserved.