



COD-1500S1A1

**SICK**  
Sensor Intelligence.



## Ordering information

Type	Part no.
COD-1500S1A1	2094149

Other models and accessories → [www.sick.com/](http://www.sick.com/)

## Detailed technical data

### Technical specifications

<b>Accessory group</b>	Device protection (mechanical)
<b>Accessory family</b>	Protective housings and protective pipes
<b>Suitable for</b>	Column device COD for light grid MLG-2
<b>Material</b>	Aluminum (column device), Aluminum die-cast base plate
<b>Dimensions (W x H x L)</b>	155 mm x 155 mm x 1,500 mm (column device)
<b>Description</b>	2 FlexFix brackets required per column device. You need two column devices to mount the sender and receiver. See mounting instructions (8022834).
<b>Weight</b>	Approx. 8.2 kg

### Classifications

<b>ECLASS 5.0</b>	27279202
<b>ECLASS 5.1.4</b>	27279202
<b>ECLASS 6.0</b>	27279202
<b>ECLASS 6.2</b>	27279202
<b>ECLASS 7.0</b>	27279202
<b>ECLASS 8.0</b>	27279202
<b>ECLASS 8.1</b>	27279202
<b>ECLASS 9.0</b>	27273701
<b>ECLASS 10.0</b>	27273701
<b>ECLASS 11.0</b>	27273701
<b>ECLASS 12.0</b>	27273701
<b>ETIM 5.0</b>	EC002615
<b>ETIM 6.0</b>	EC002615
<b>ETIM 7.0</b>	EC002615
<b>ETIM 8.0</b>	EC002615
<b>UNSPSC 16.0901</b>	32131023

Dimensional drawing (Dimensions in mm (inch))

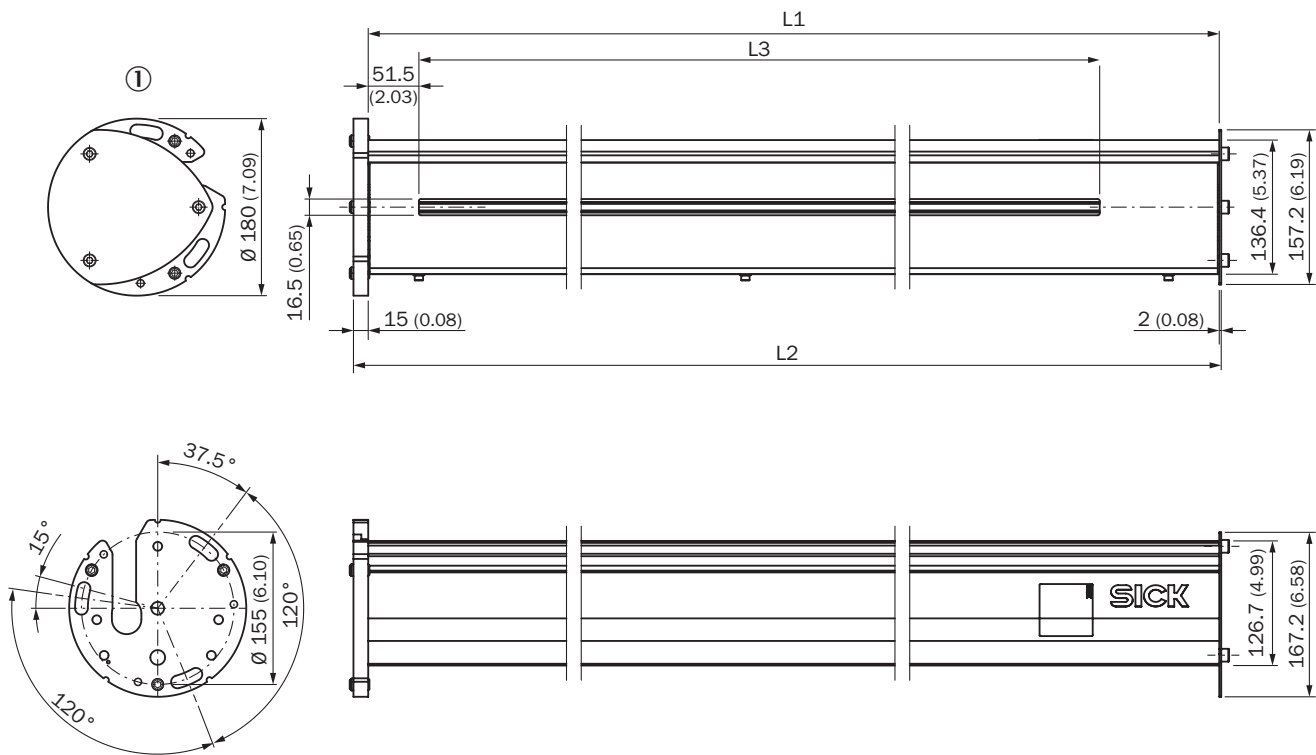

① Mounting plate

		<b>L1</b>	<b>L2</b>	<b>L3</b>
2094149	COD-1500S1A1	1,500 mm	1,517 mm	1,327 mm
2101607	COD-2000S1A1	2,000 mm	2,017 mm	1,800 mm
2094150	COD-2400S1A1	2,400 mm	2,417 mm	2,122 mm

## SICK AT A GLANCE

SICK is one of the leading manufacturers of intelligent sensors and sensor solutions for industrial applications. A unique range of products and services creates the perfect basis for controlling processes securely and efficiently, protecting individuals from accidents and preventing damage to the environment.

We have extensive experience in a wide range of industries and understand their processes and requirements. With intelligent sensors, we can deliver exactly what our customers need. In application centers in Europe, Asia and North America, system solutions are tested and optimized in accordance with customer specifications. All this makes us a reliable supplier and development partner.

Comprehensive services complete our offering: SICK LifeTime Services provide support throughout the machine life cycle and ensure safety and productivity.

For us, that is “Sensor Intelligence.”

## WORLDWIDE PRESENCE:

Contacts and other locations –[www.sick.com](http://www.sick.com)