

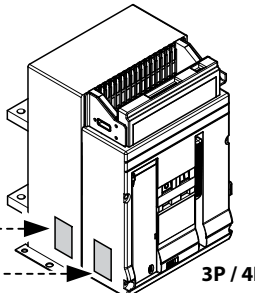

LE08449AB

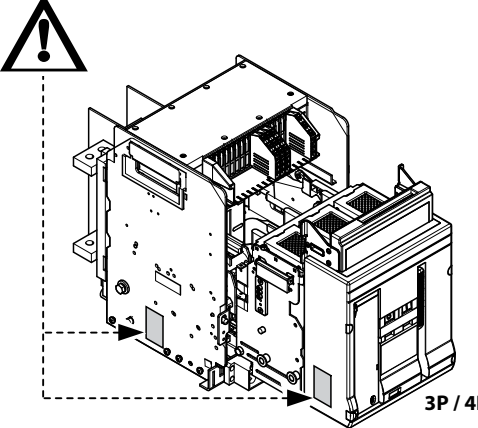





DMX<sup>3</sup> 1600 3P  
In 630A  
Fixed  
Frame 1600  
Icu 42kA at 415V  
0 280 00

3414970 XXXXXXXXXXXXX  
**legrand®**  
Made in China  
17 W xx 0,80

LEGRAND - BP 30076  
87002 LIMOGES CEDEX FRANCE



DMX<sup>3</sup> 1600 3P  
In 630A  
Fixed  
Frame 1600  
Icu 42kA at 415V  
0 280 00

3414970 XX XXXXXXXXXXXXX  
**legrand®**  
Made in China  
18 W xx 1,80

LEGRAND - BP 30076  
87002 LIMOGES CEDEX FRANCE

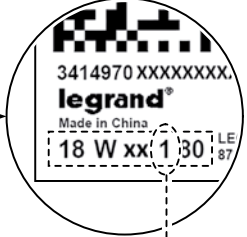

3414970 XXXXXXXXXXXXX  
**legrand®**  
Made in China  
18 W xx 1,80

18W XX 1,80

≤ 1 → ✓

< 1 → 

**legrand®**

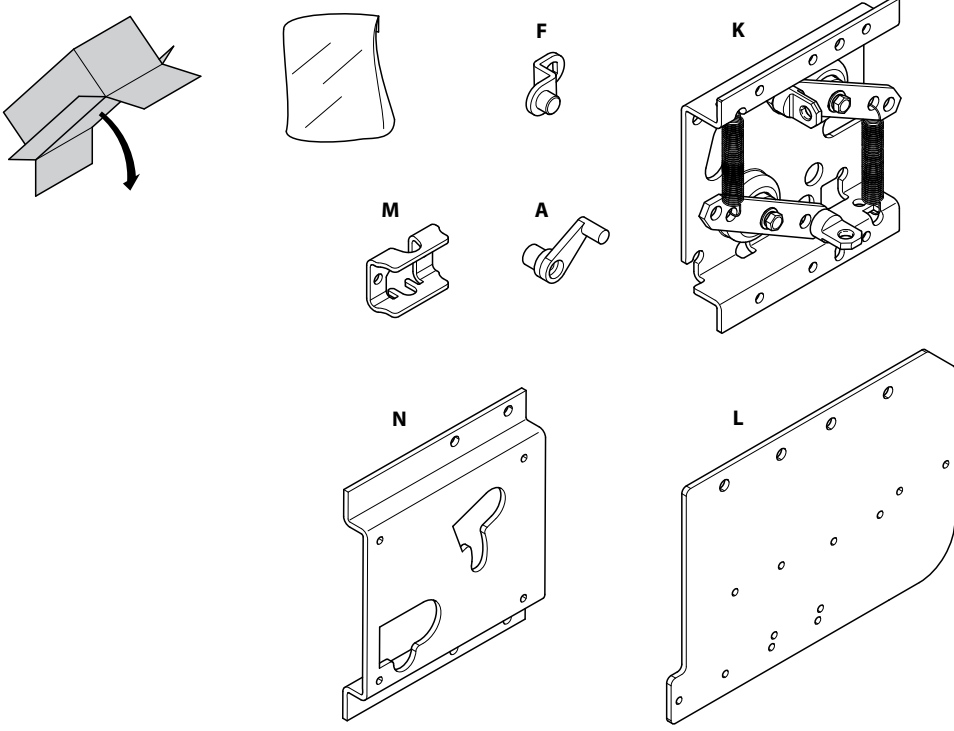



**D**  ø 6,5 x 4,5 mm

**C**  ø 8 x 4,5 mm

**B** 

**E**  M3

**I**  ø 8 x 5,5 mm

**H**  ø 10 x 5,5 mm

**G**  ø 11 x 4,5 mm

**J**  M4

**O** 

	Fixe Fixed Fija Vaste Fixa Σταθερή Стационарное Niewyjmowalna Sabit	Débrochable Draw-out Desmontable Wegneembare Removível Αποσπώμενη Выкатное Wyjmwalna Çıkarılabilir
<b>A</b>	1	0
<b>B</b>	1	0
<b>C</b>	12	8
<b>D</b>	13	9
<b>E</b>	13	9
<b>F</b>	1	1
<b>G</b>	1	1
<b>H</b>	2	2
<b>I</b>	2	2
<b>J</b>	2	2
<b>K</b>	1	1
<b>L</b>	1	1
<b>M</b>	2	2
<b>N</b>	1	0
<b>O</b>	4	4

LE08449AB

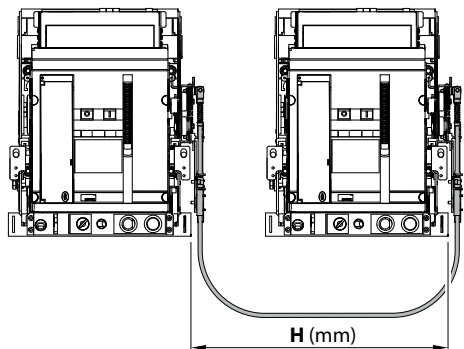

$L = 620 + 700 (H) = 1420 \text{ mm}$

LC = 1000 (ref. 0 289 17)

LC = 1500 (ref. 0 289 18)

LC ≥ L

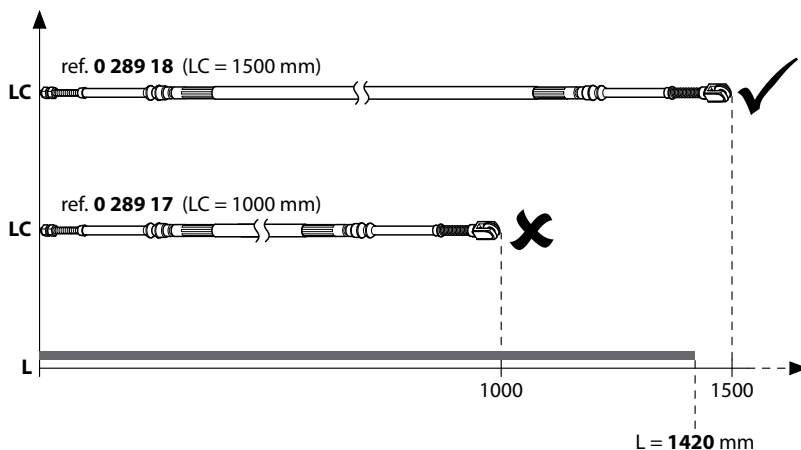

**TYPE A**

ACB ①	ACB ②
0	0
1	0
0	1

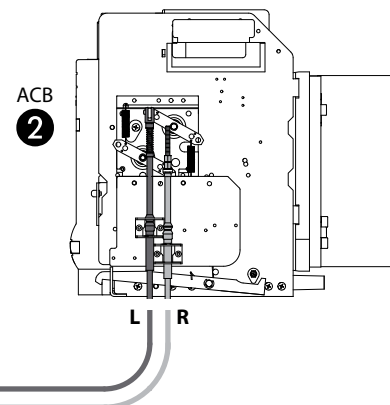
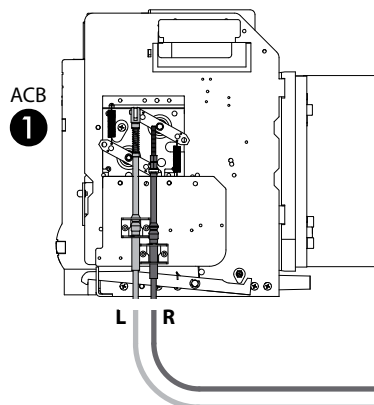
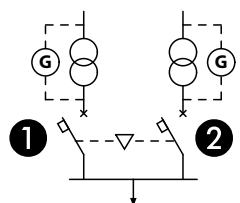

ACB		
① R	② L	.....
② R	① L	.....

Longueur du câble Cable's length Longitud del cable Lengte kabel Comprimento cabo Μήκος καλωδίου Длина тросов Długość kabla Kablo uzunluğu	Référence Reference Referencia Referentia Referència Αναφορά Кат. № Odniesienie Referans
Lc (mm)	
Lc ≥ L	
1000	0 289 17
1500	0 289 18
2600	0 289 20
3000	0 289 21
3600	0 289 22
4000	0 289 23
4600	0 289 24
5600	0 289 25

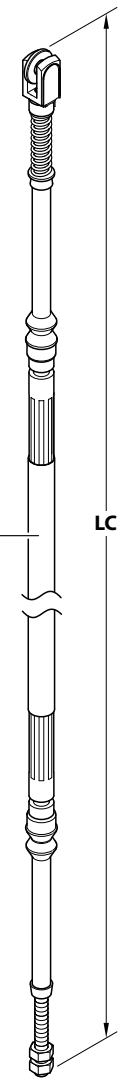
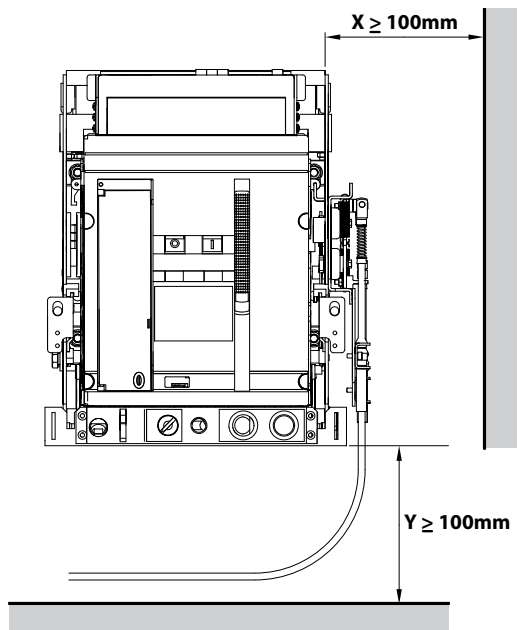

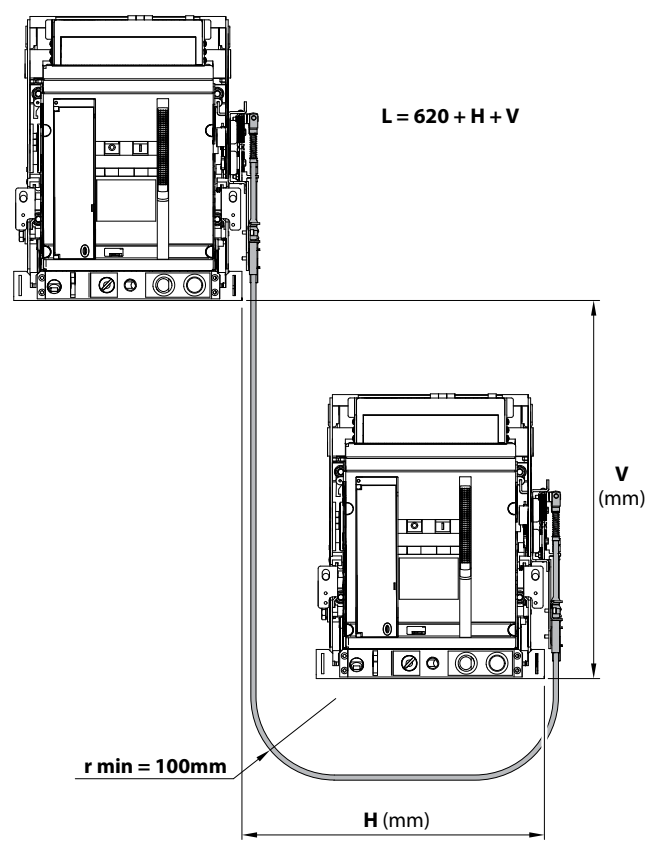
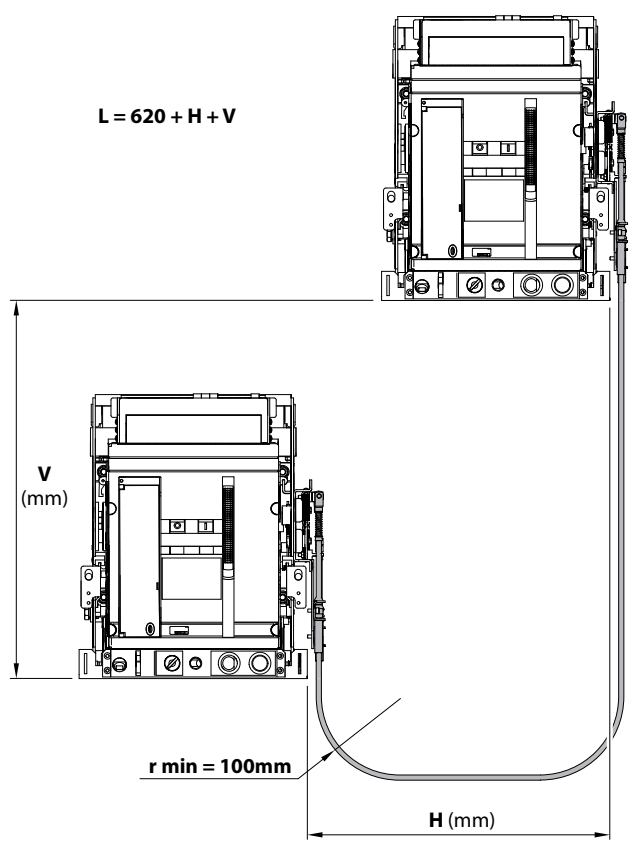
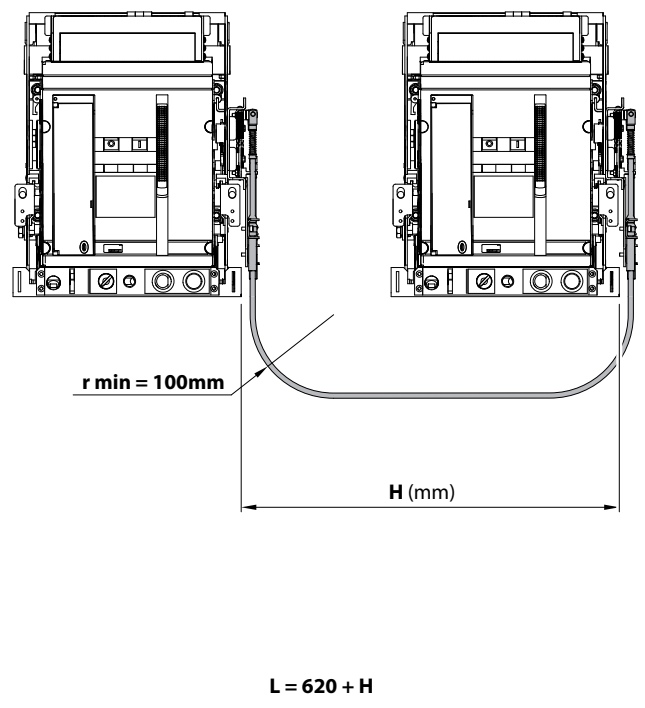
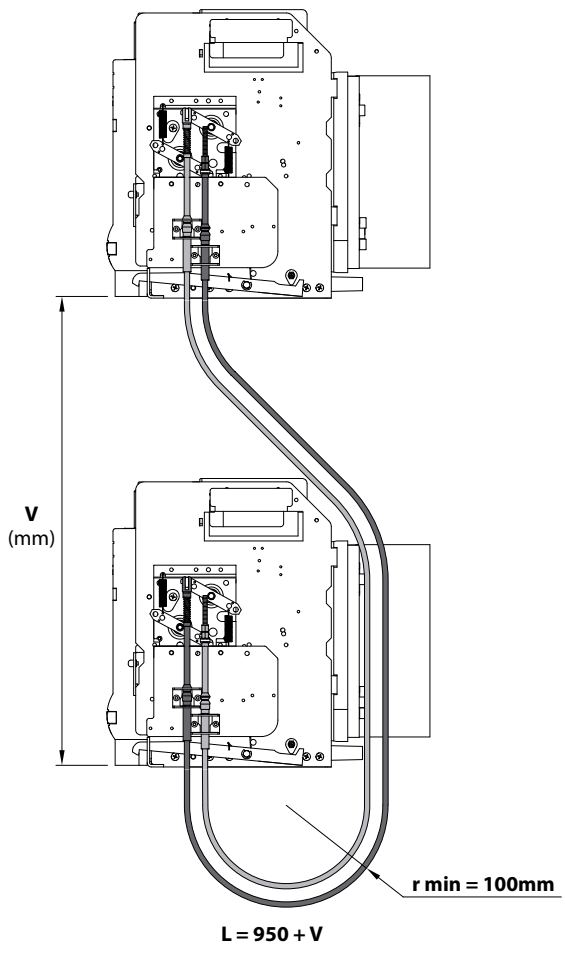

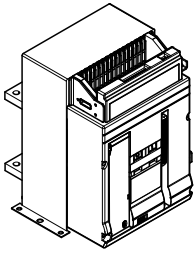

3P / 4P ●  
x1

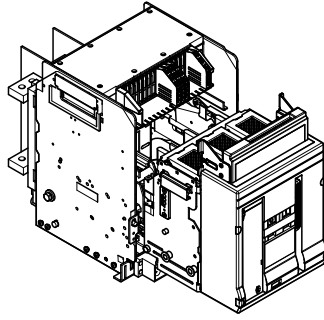

3P / 4P ○  
x1

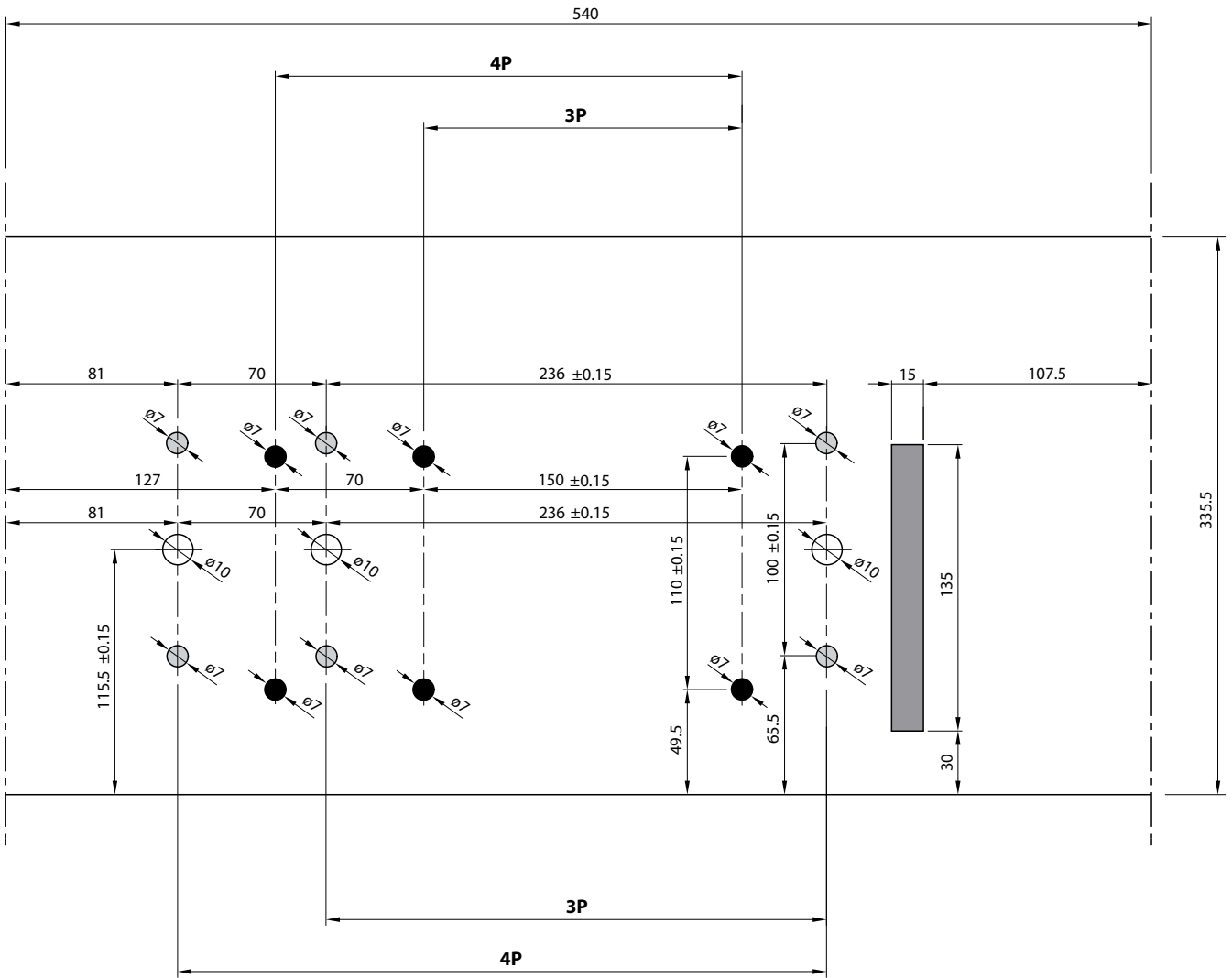

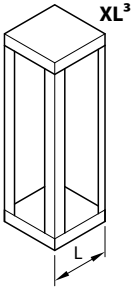

XL<sup>3</sup>

<b>0 207 80</b>
L=725
3P / 4P

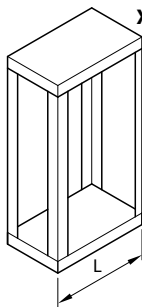
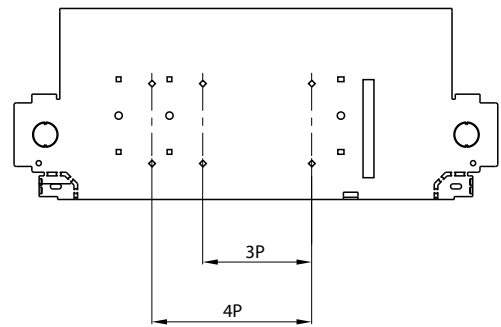
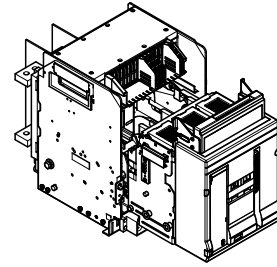
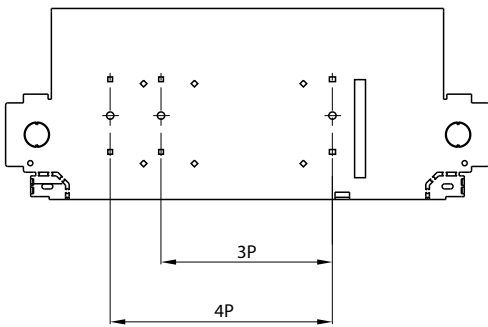
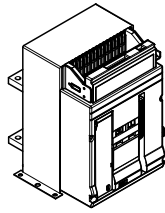

XL<sup>3</sup>

<b>0 207 81</b>
L=975
3P / 4P

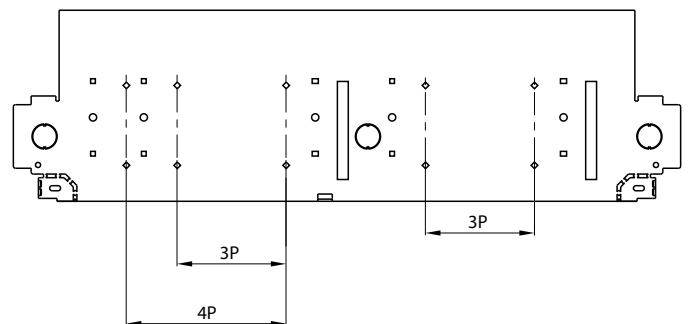
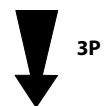
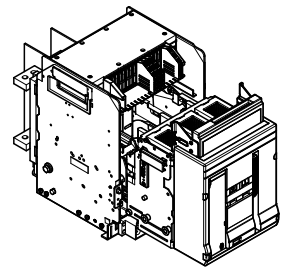
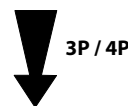
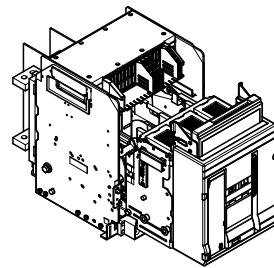
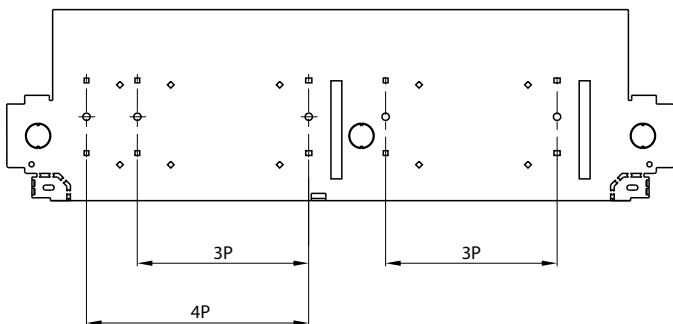
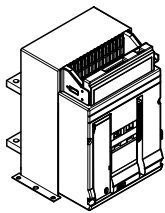
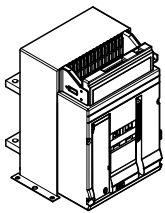

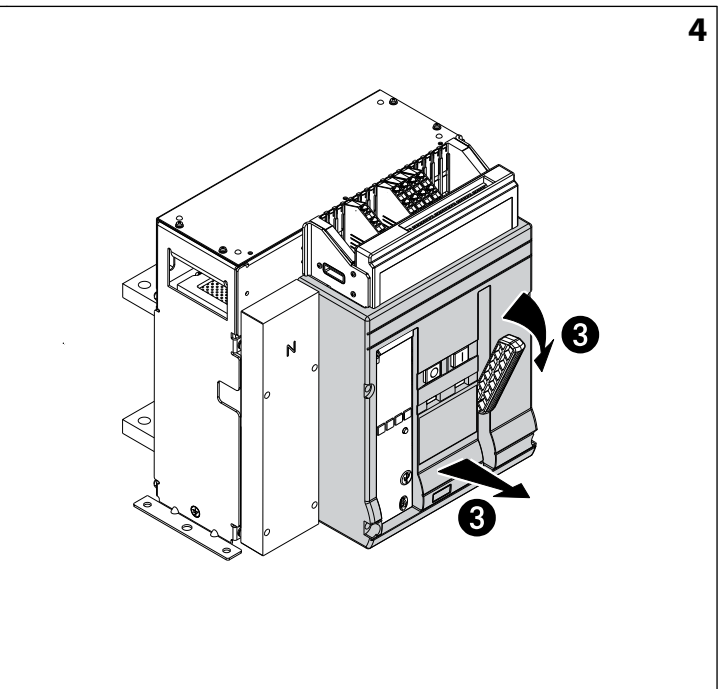
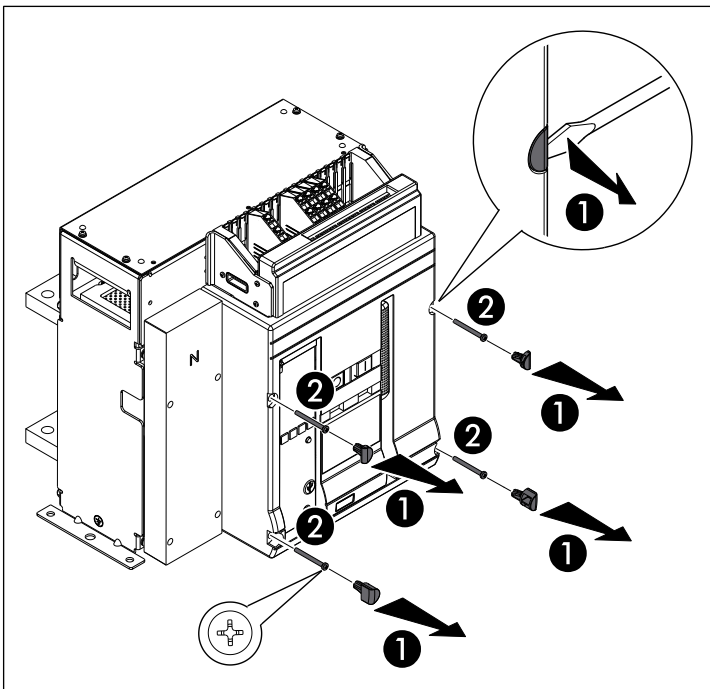
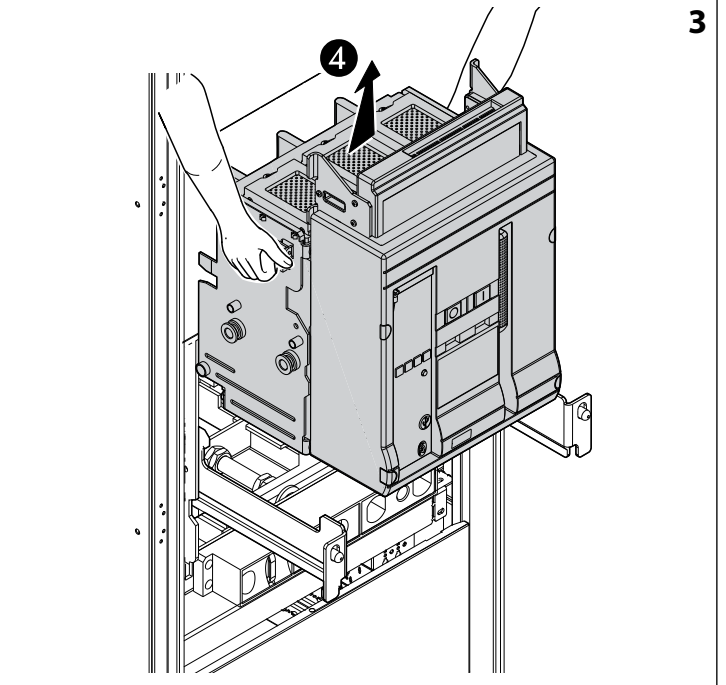
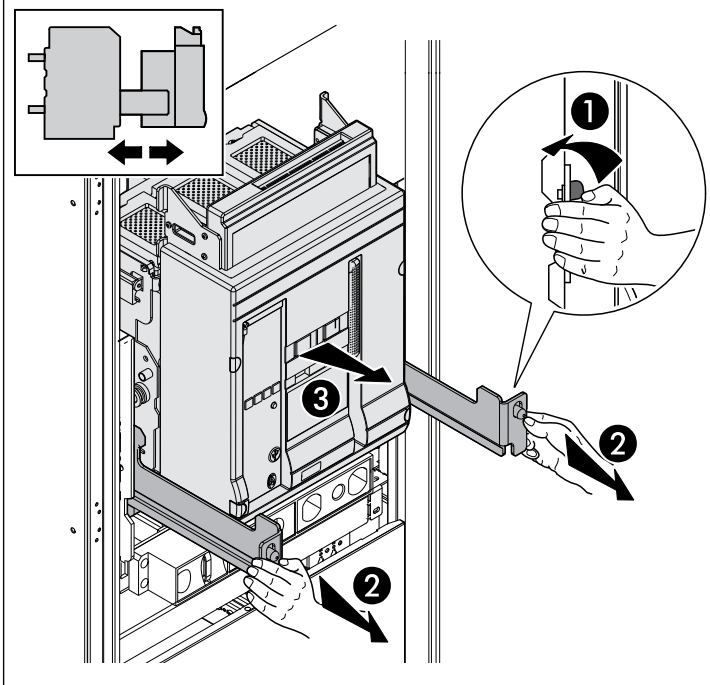
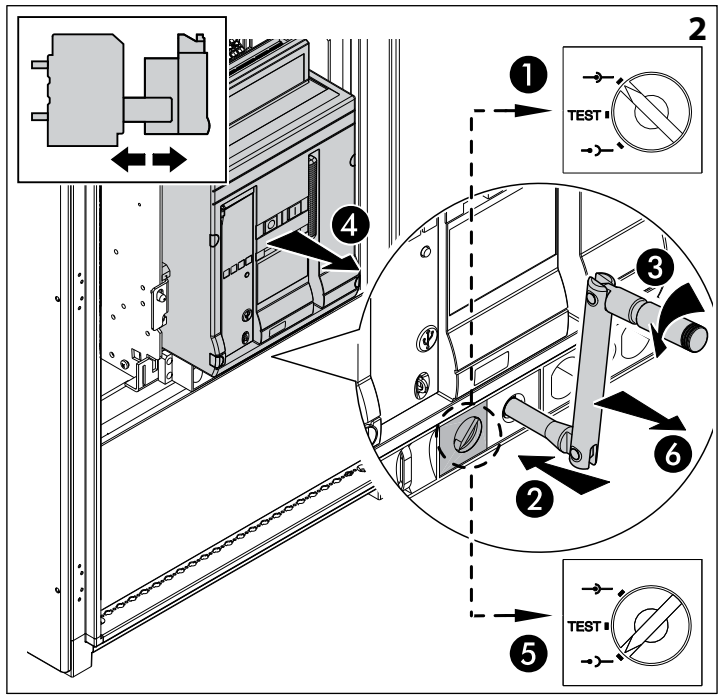
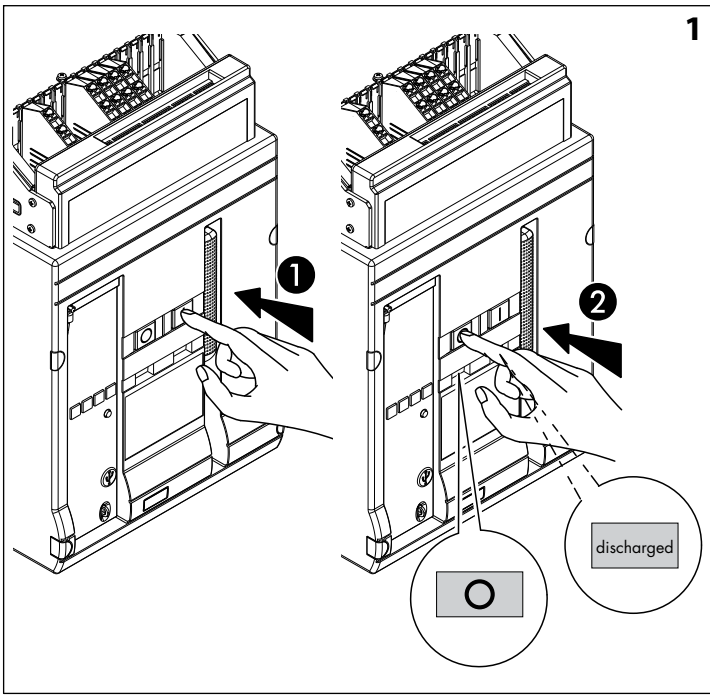

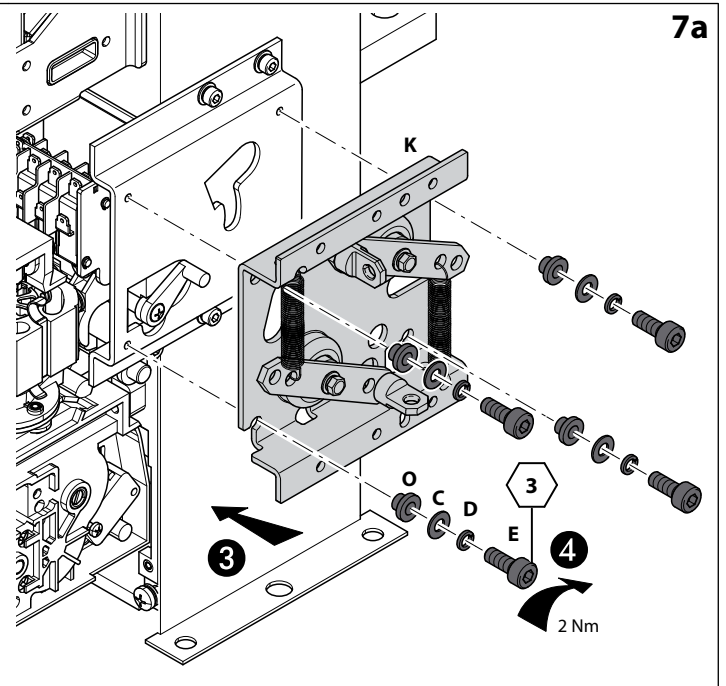
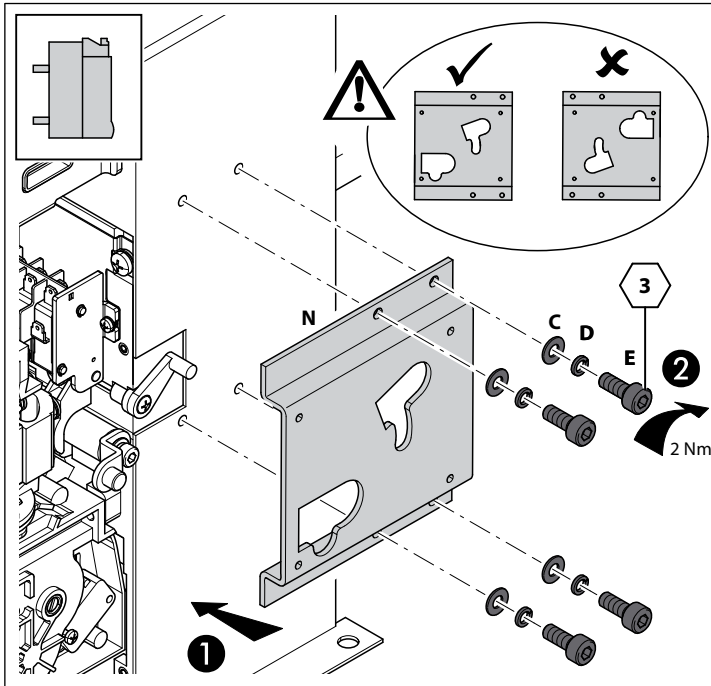
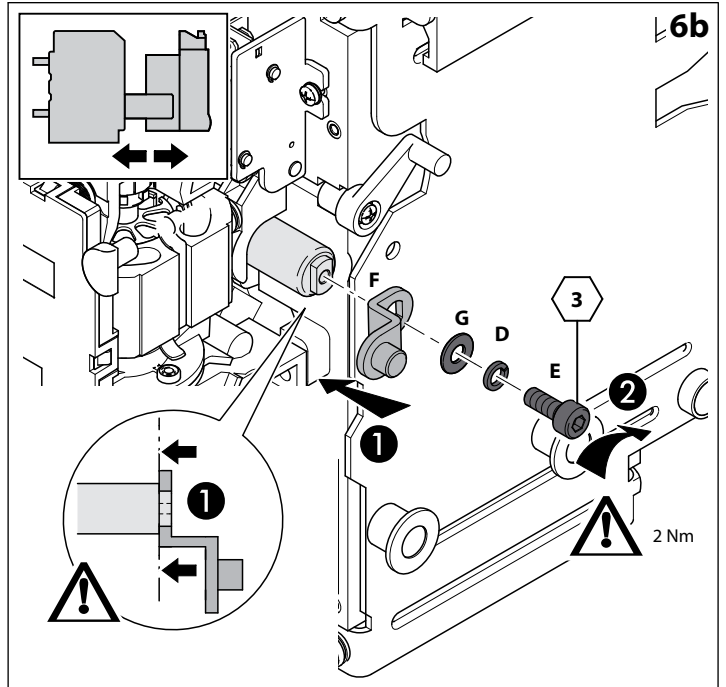
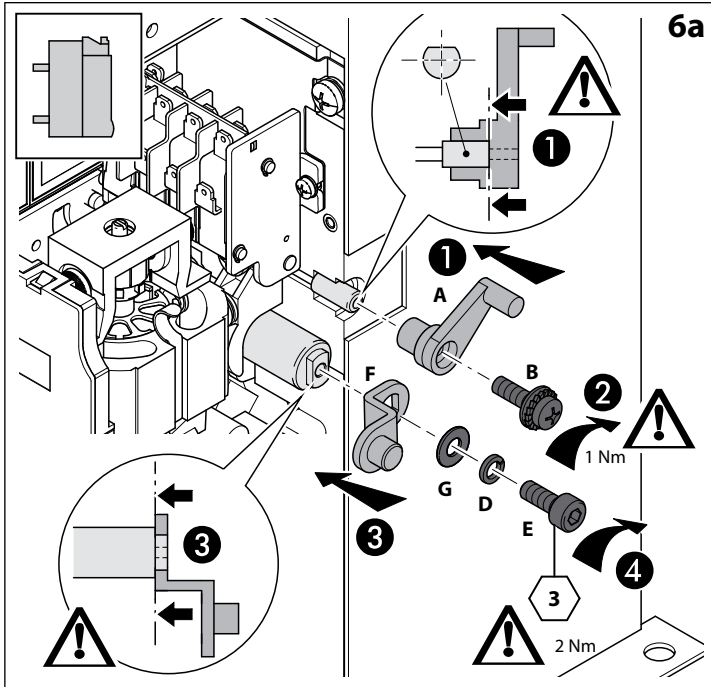
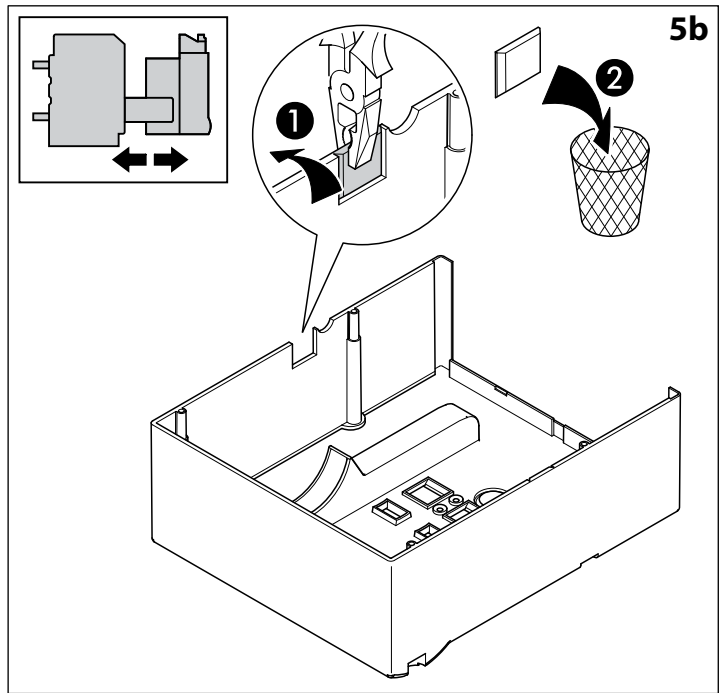
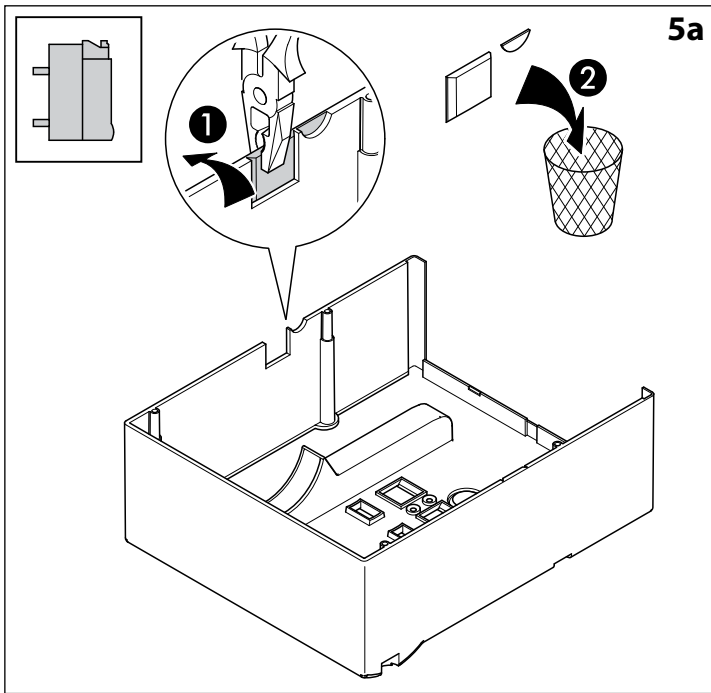

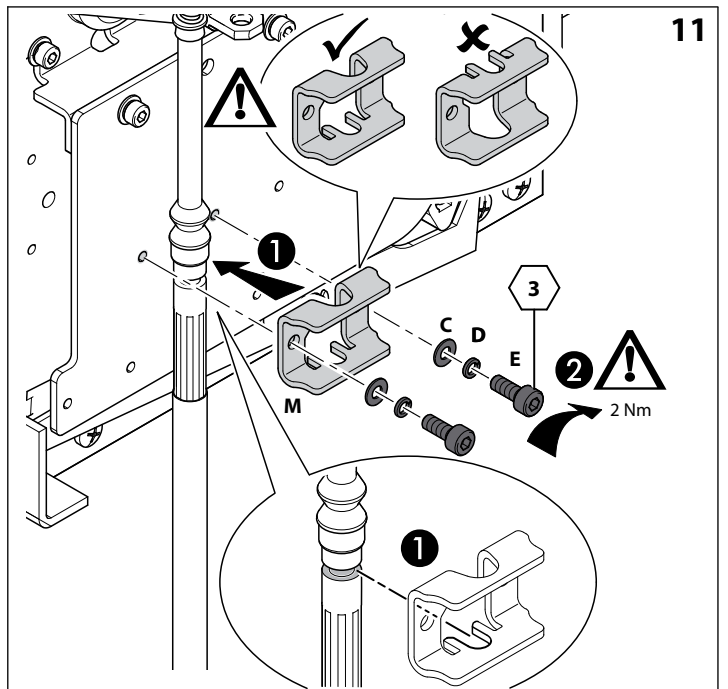
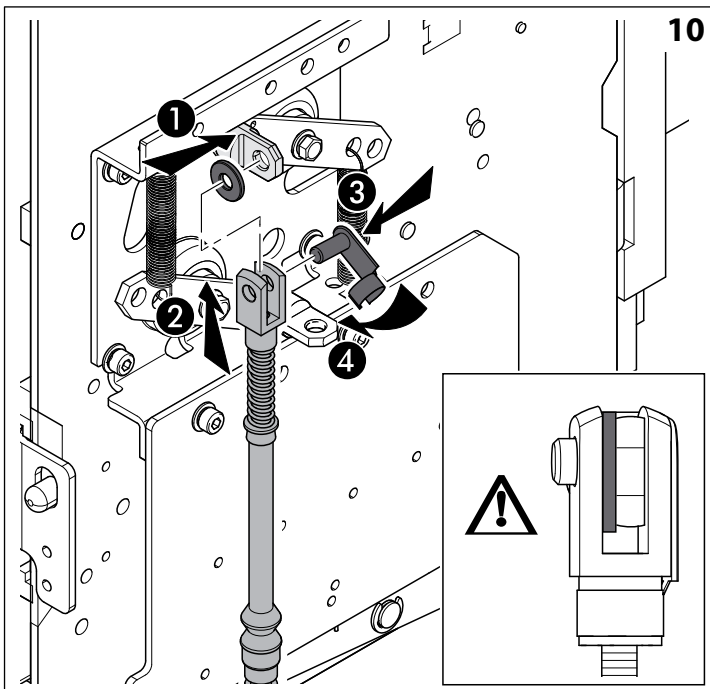
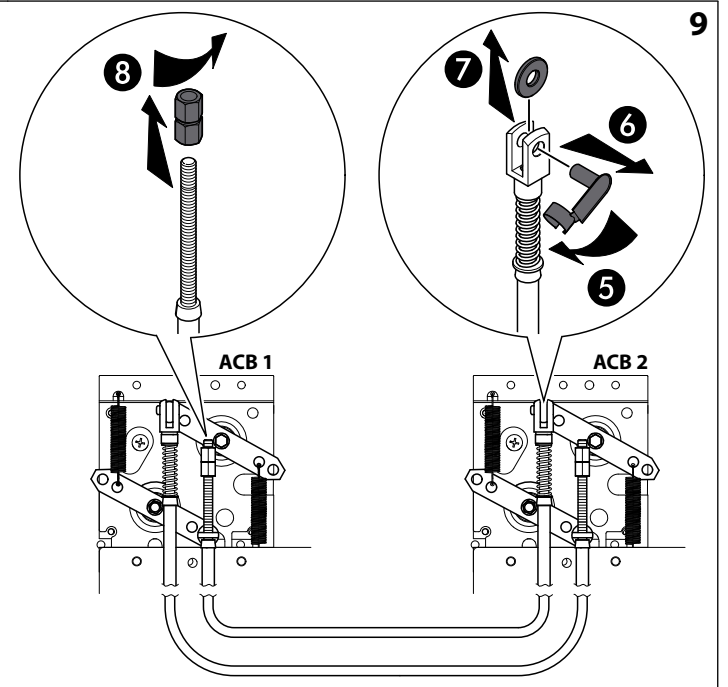
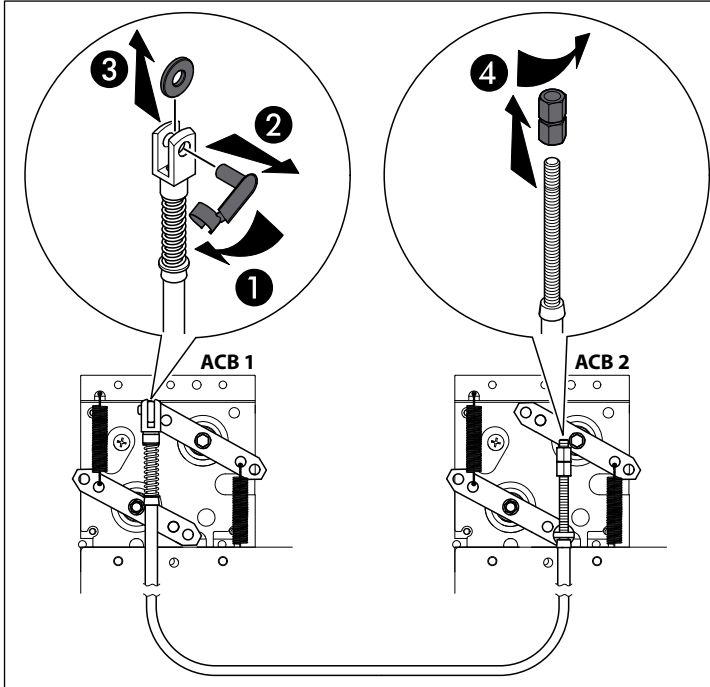
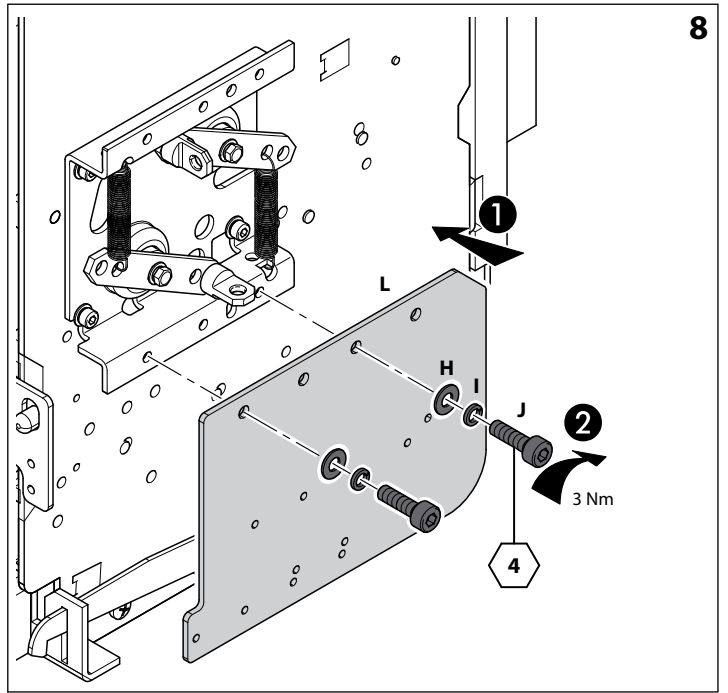
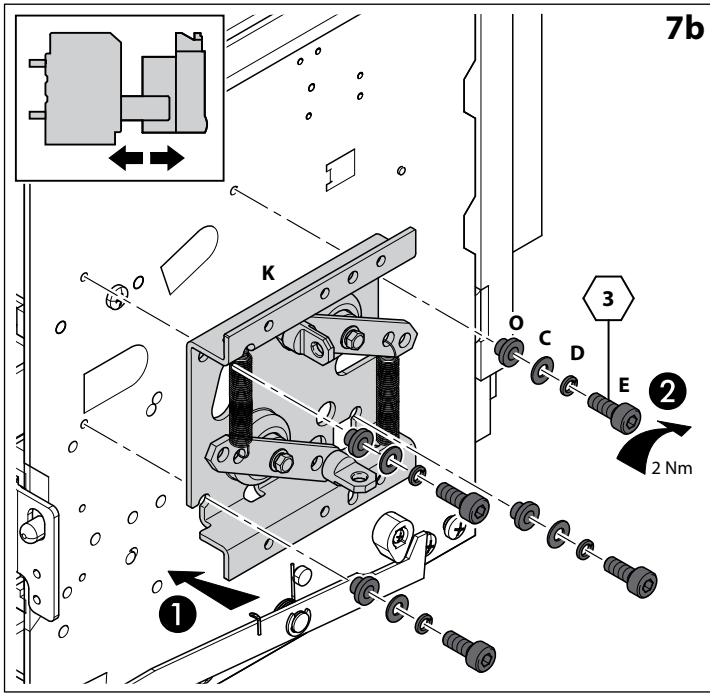



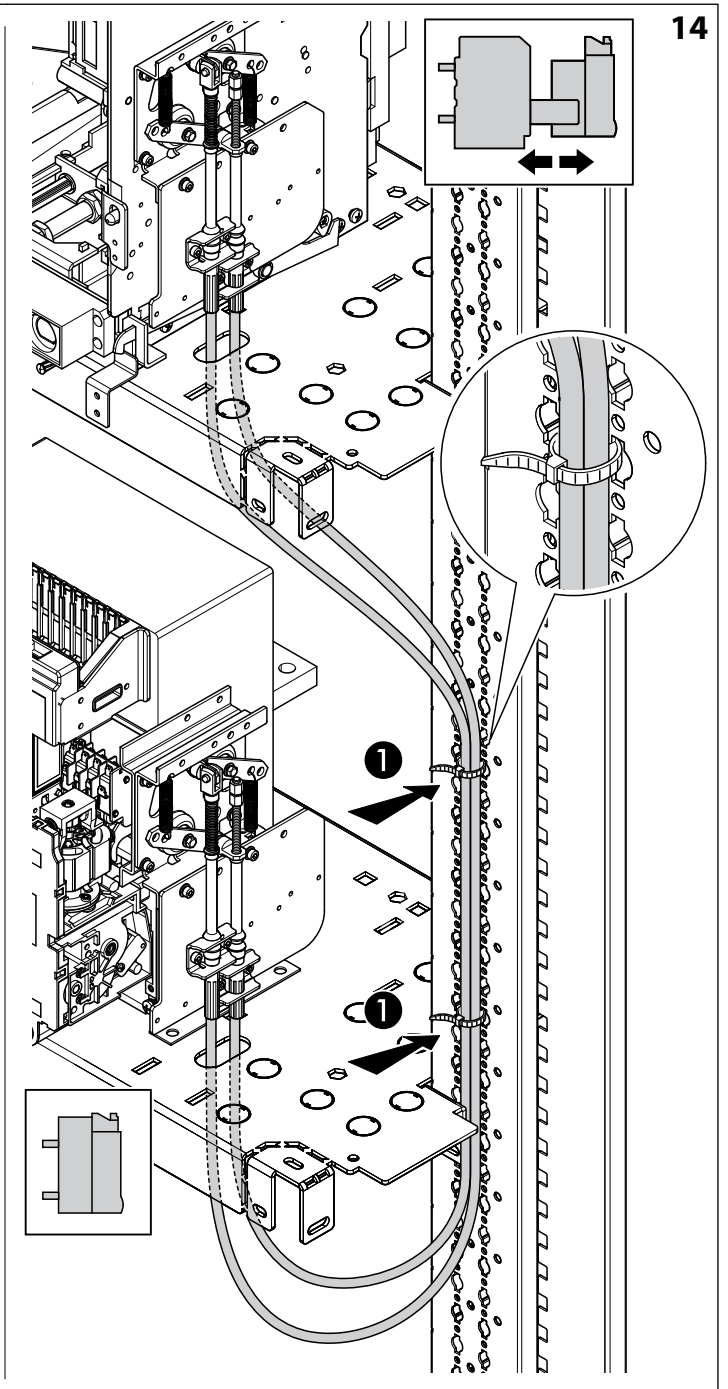
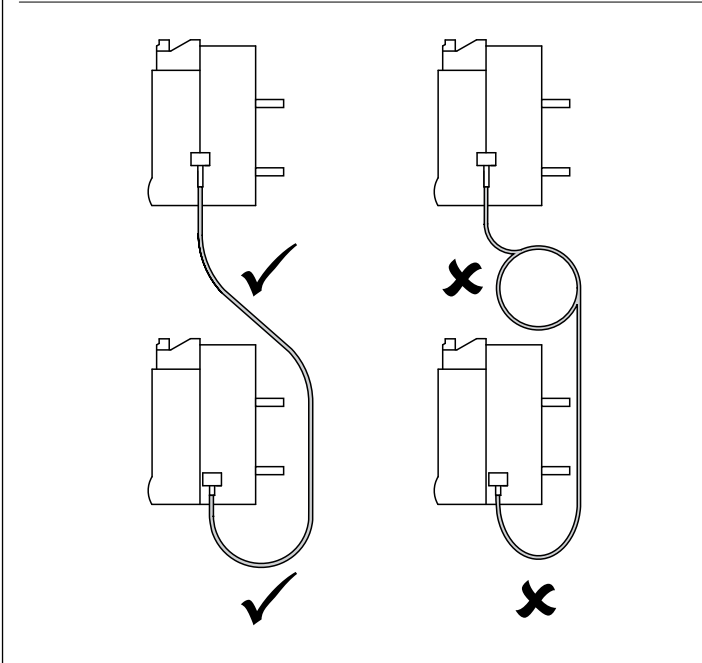
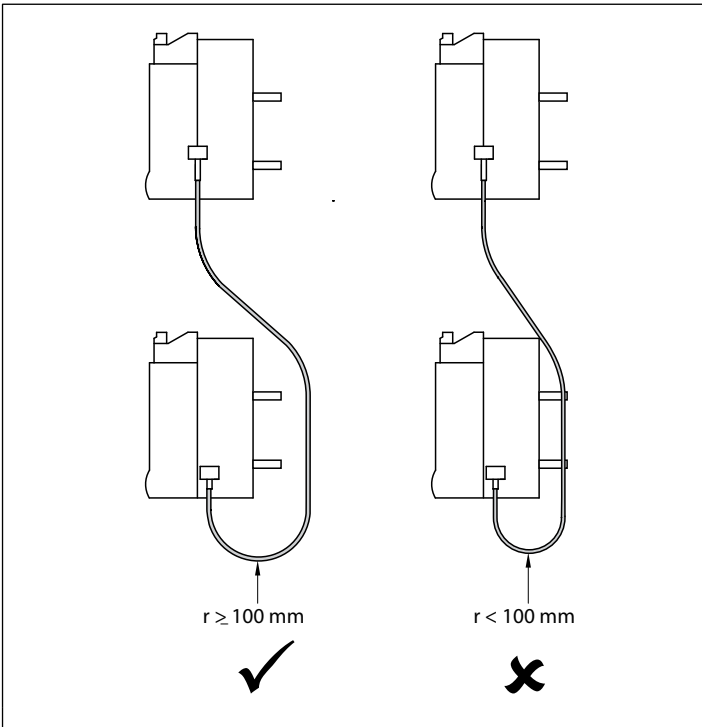
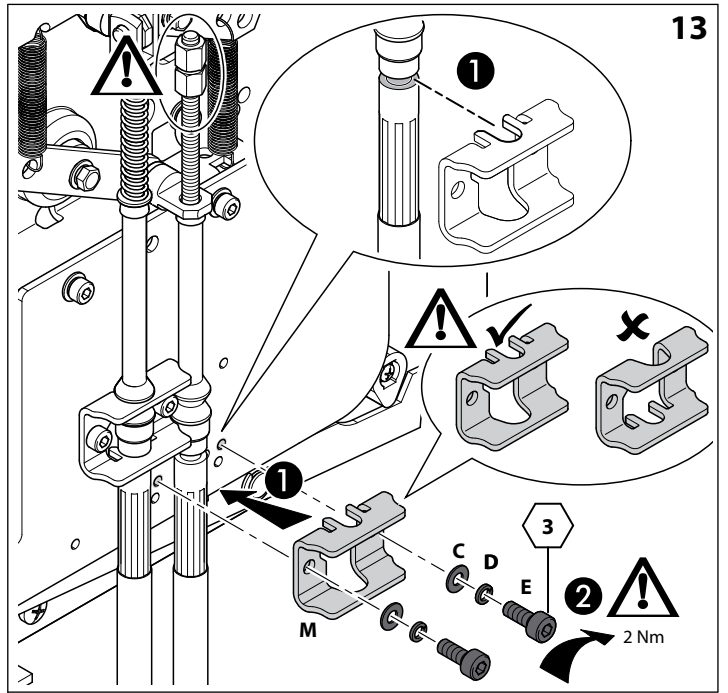
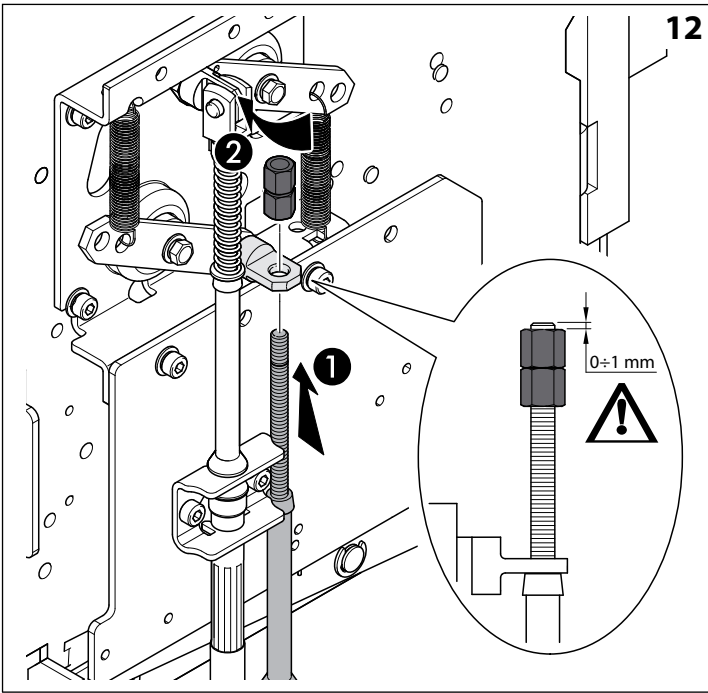

15

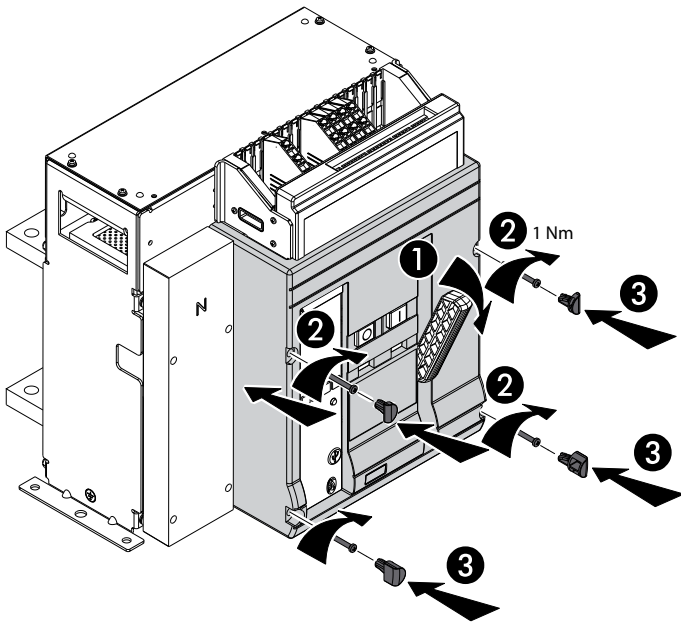

16

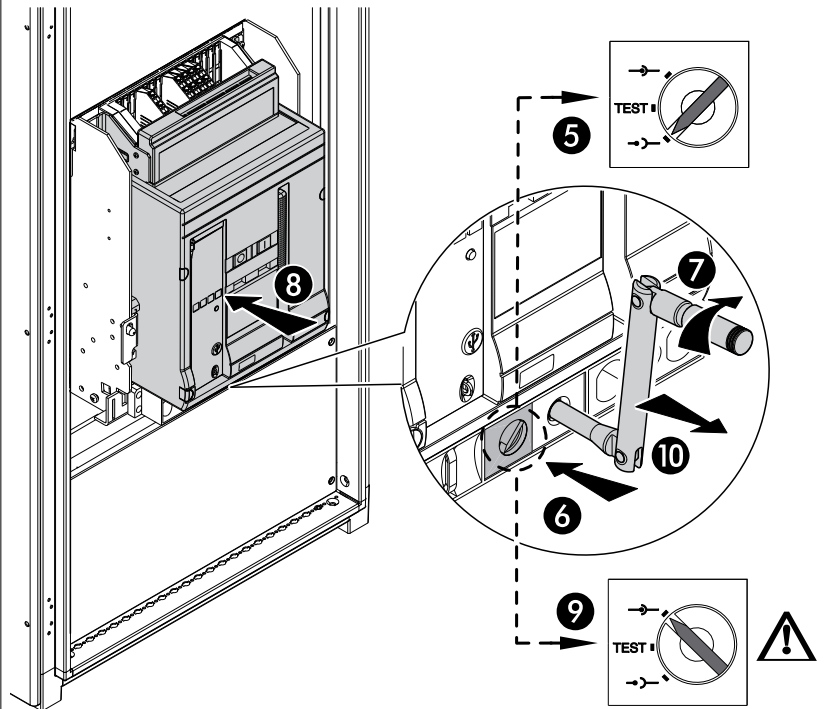
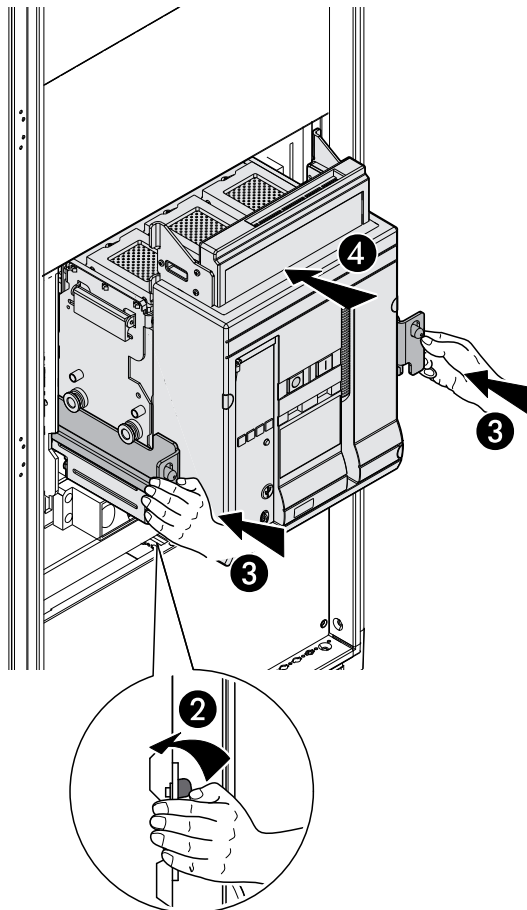
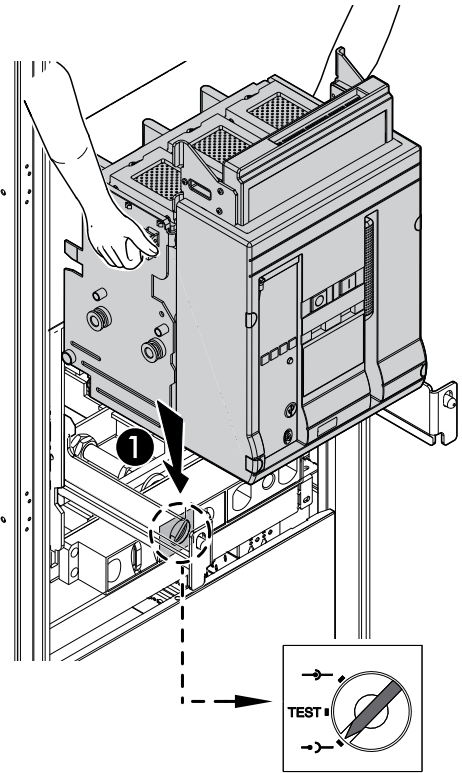
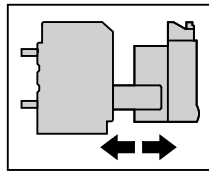

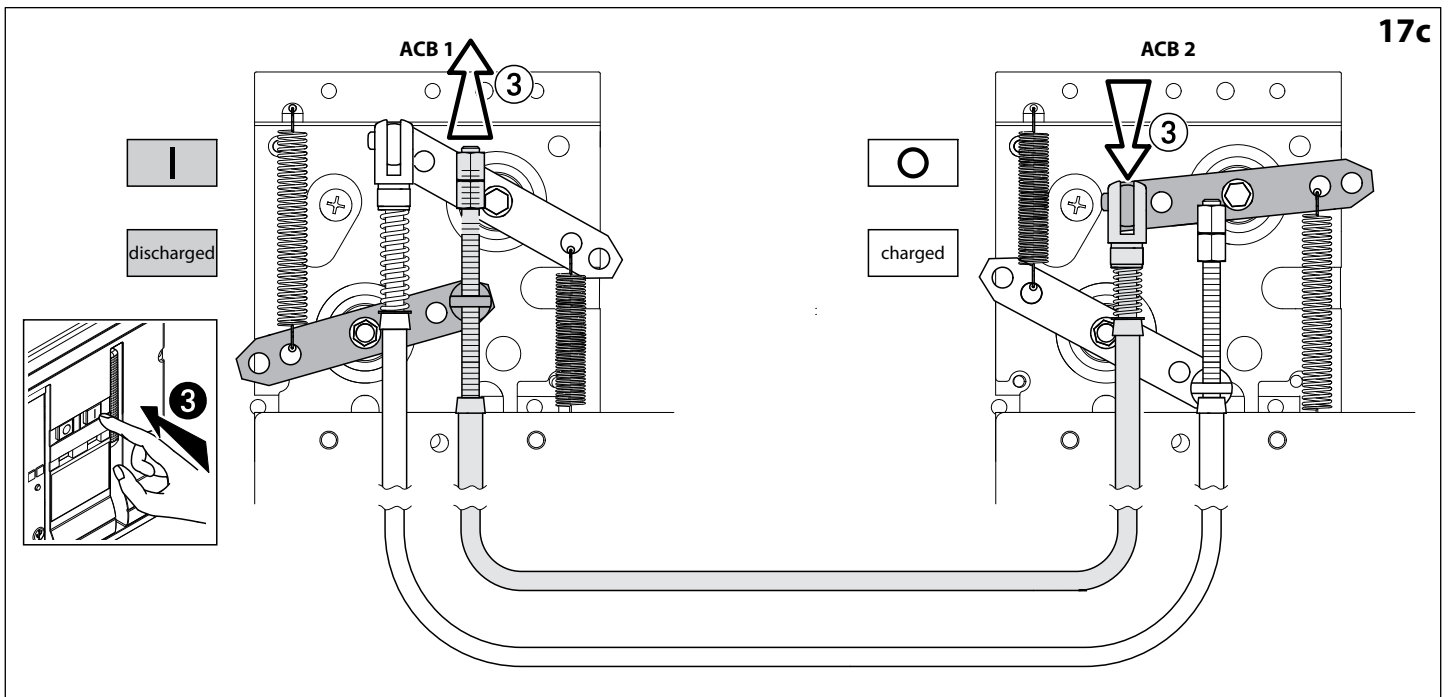
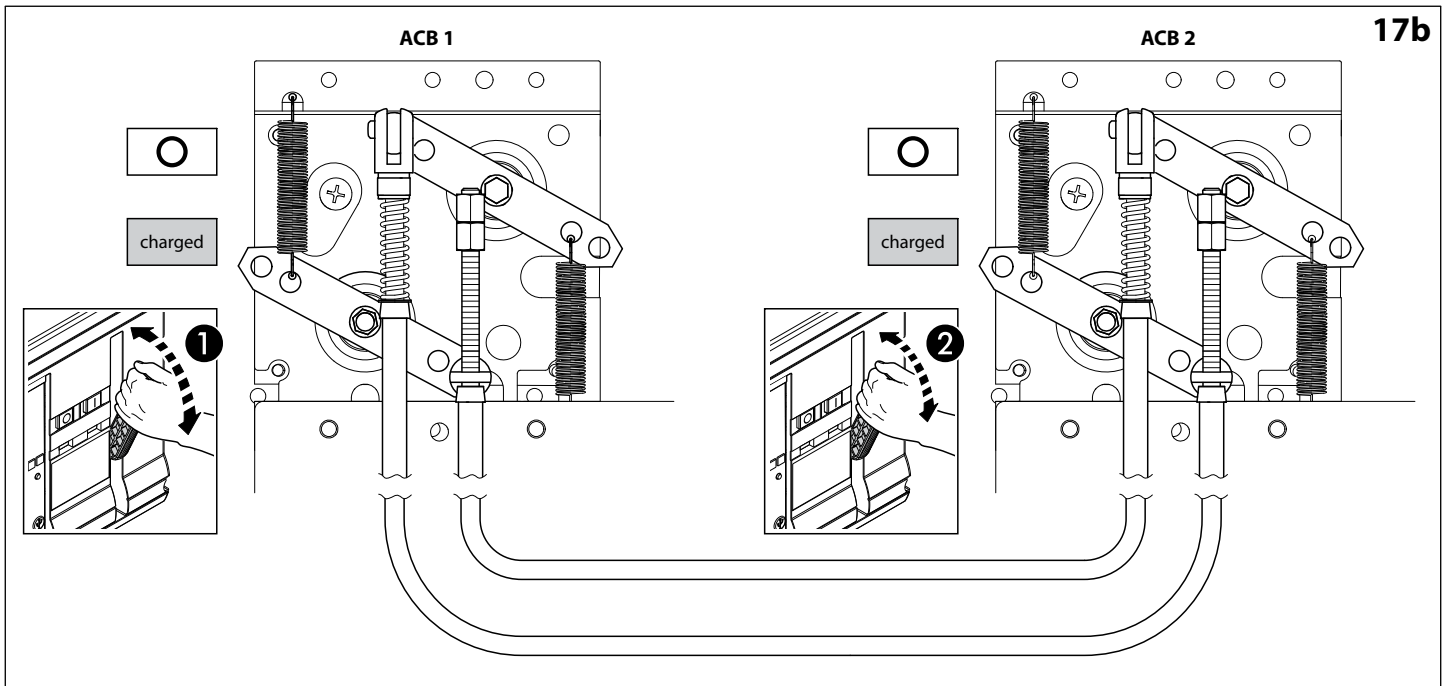
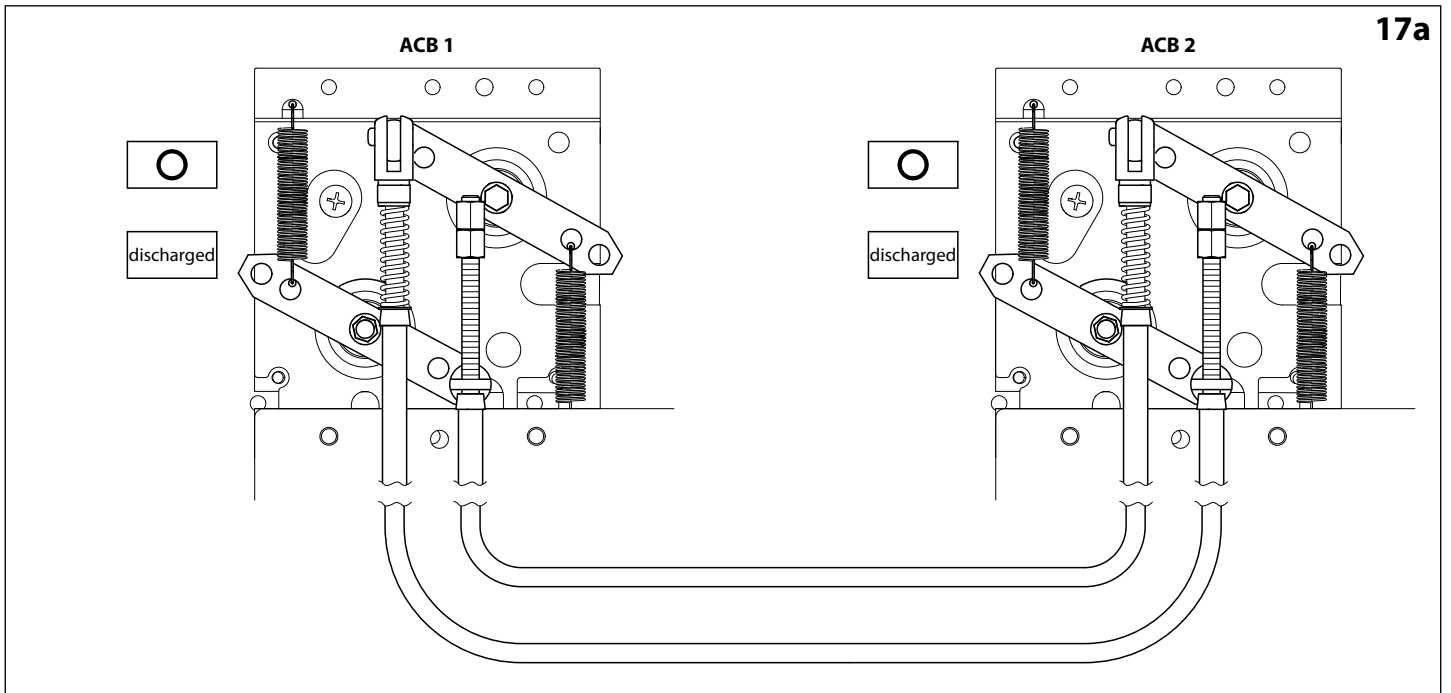

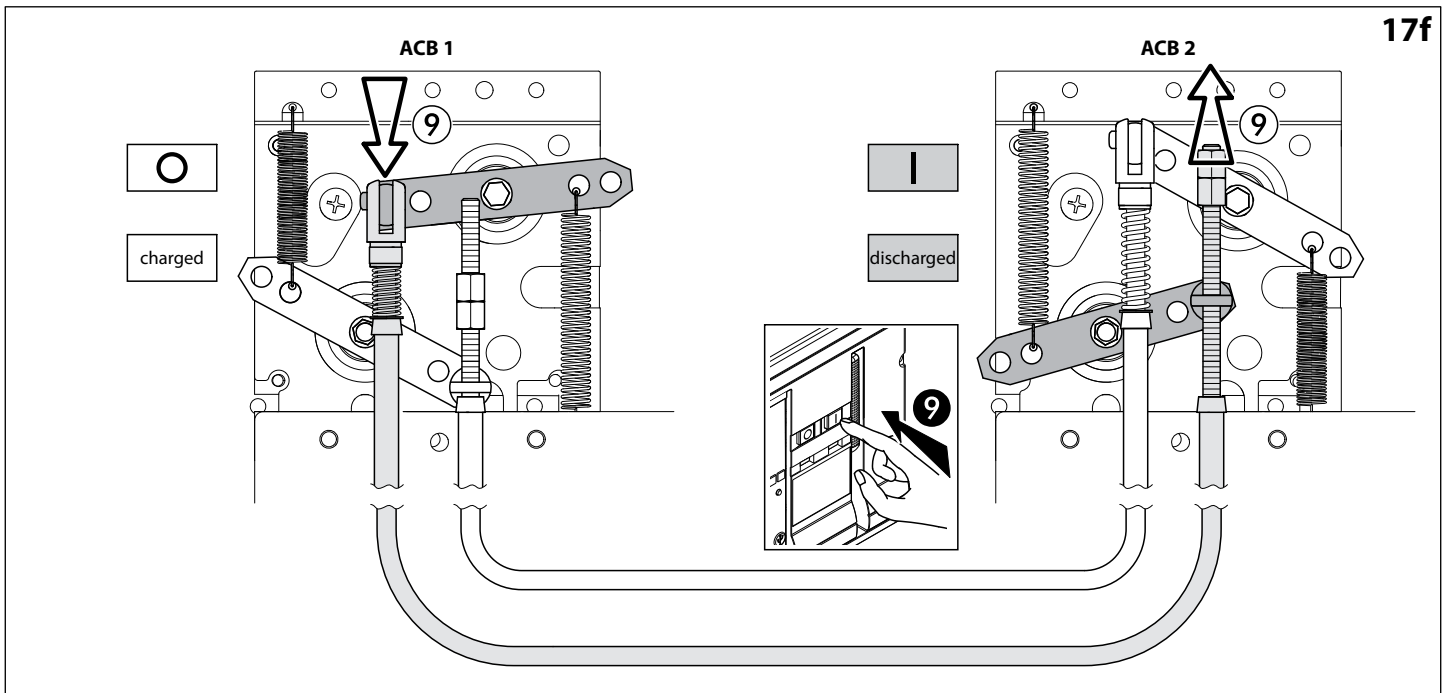
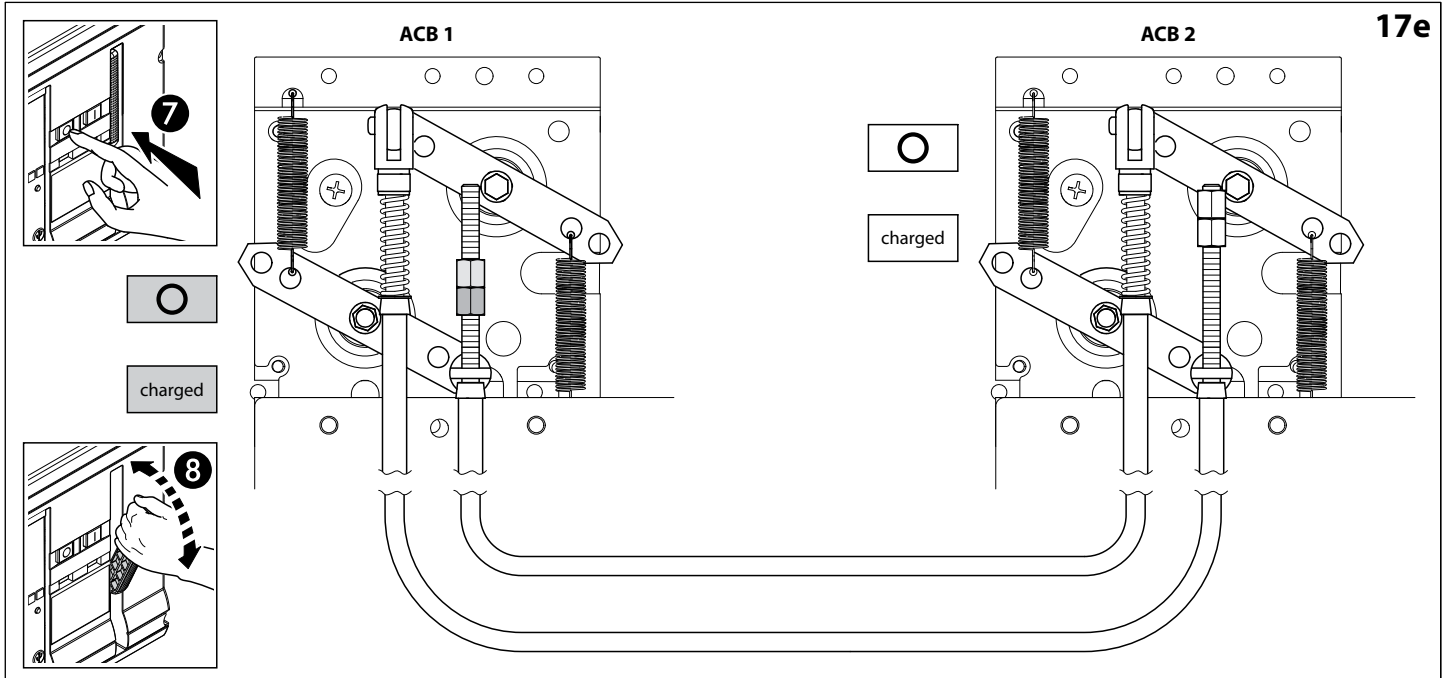
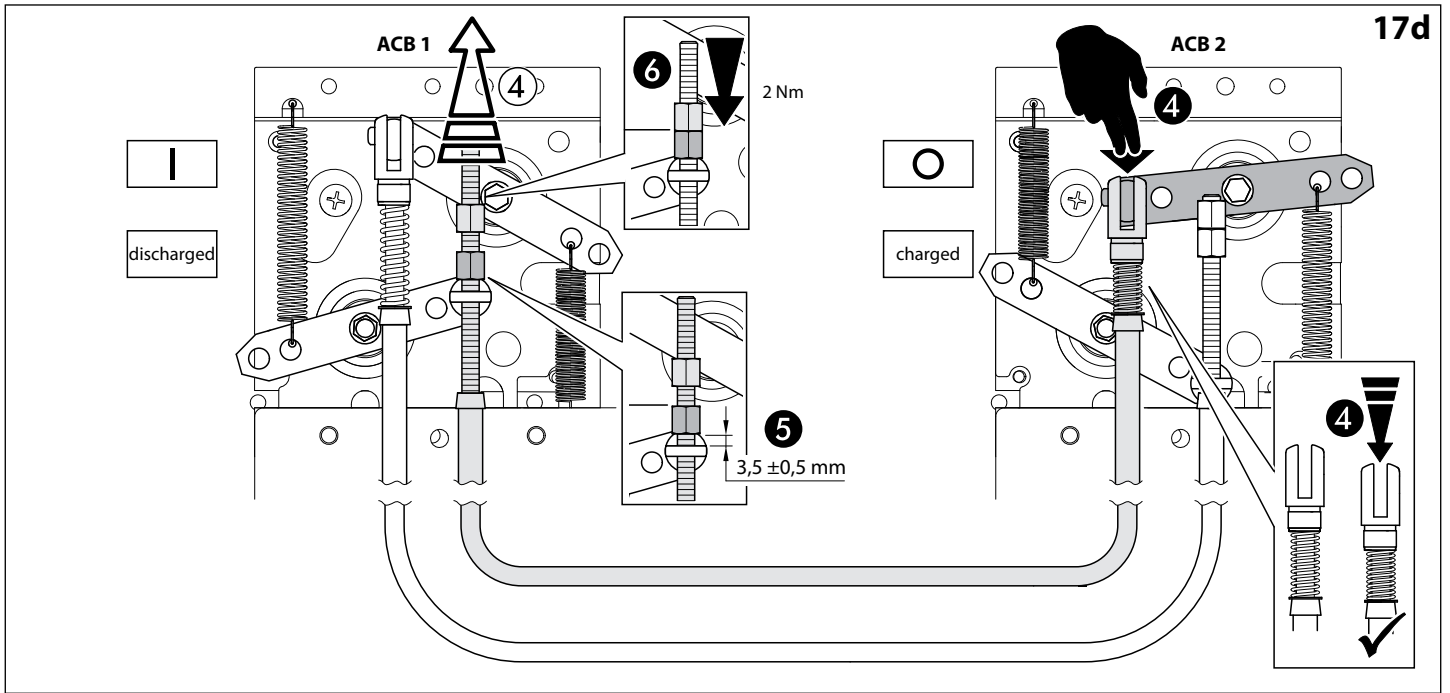

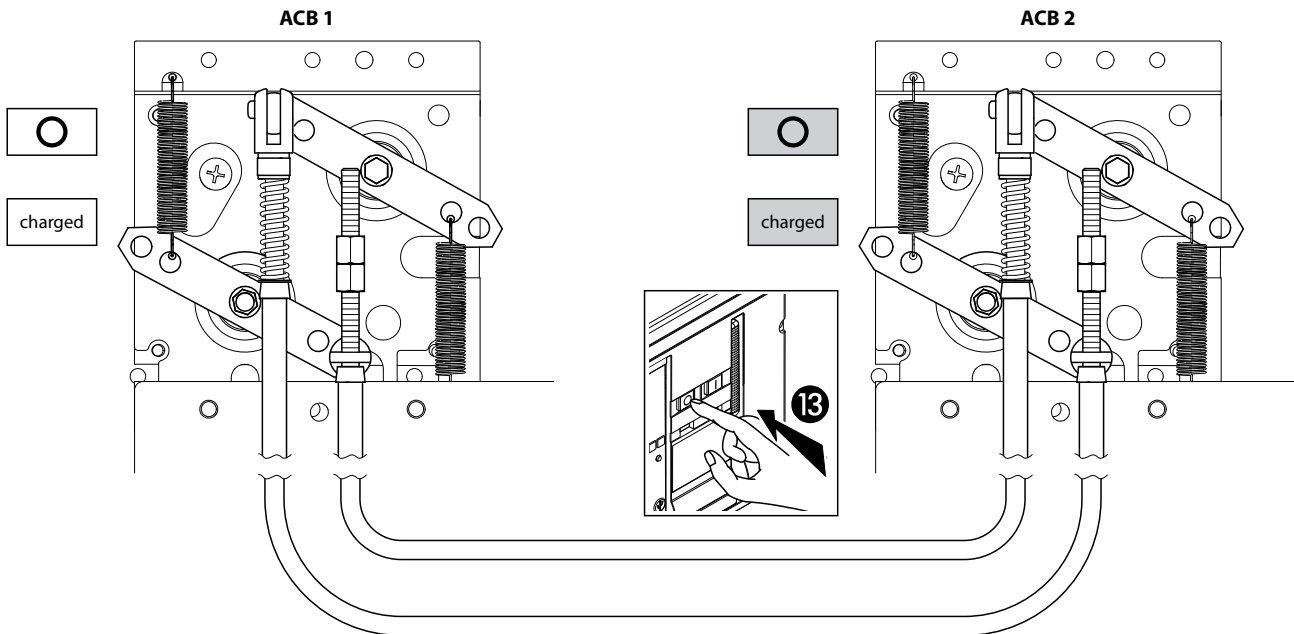
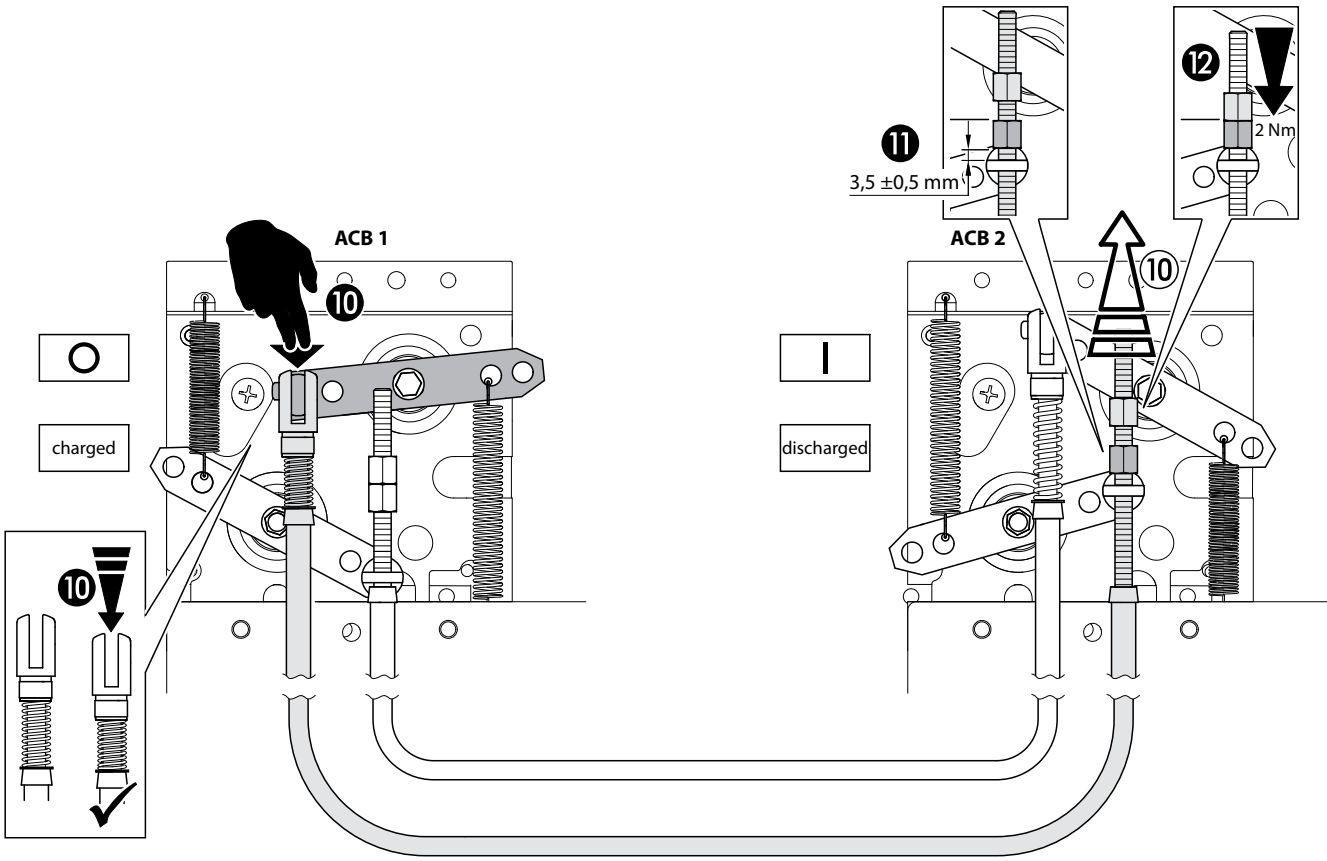

ACB 1 1



charged

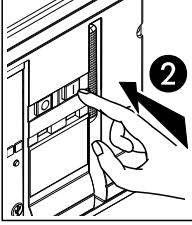
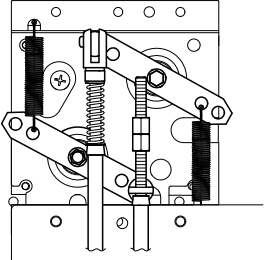

discharged

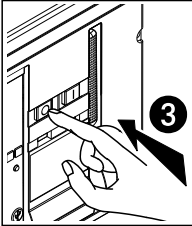
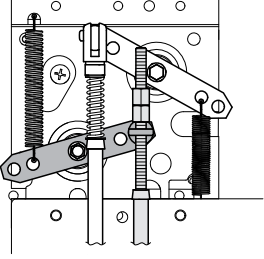

charged

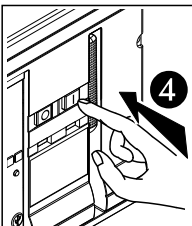
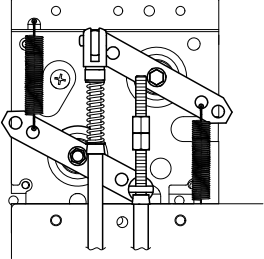

discharged

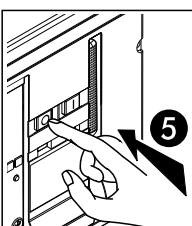
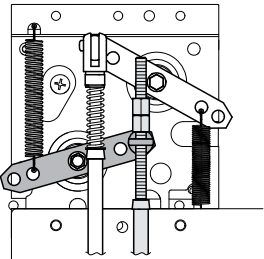

charged

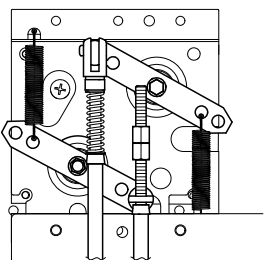

ACB 2 6



charged

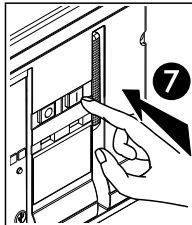
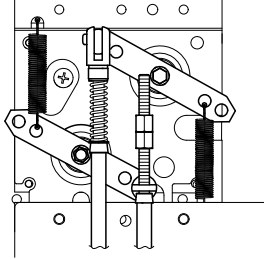

discharged

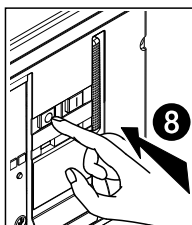
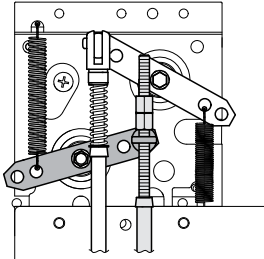

charged

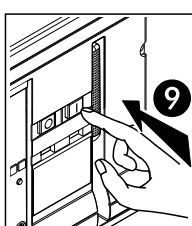
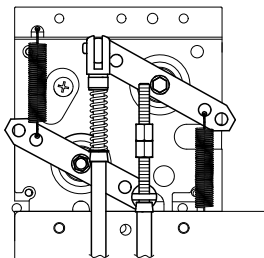

discharged

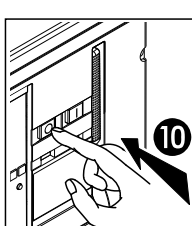
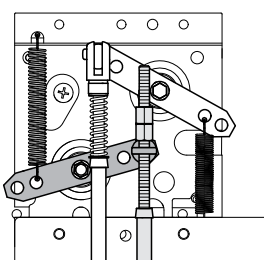

charged

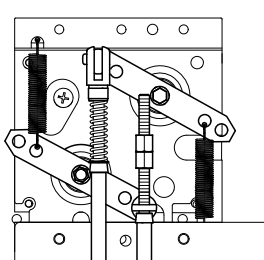

ACB 1

ACB 2



charged

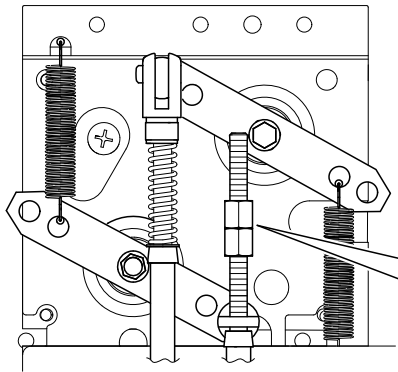

17d - 17g

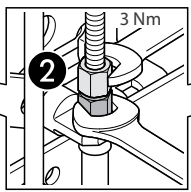

charged

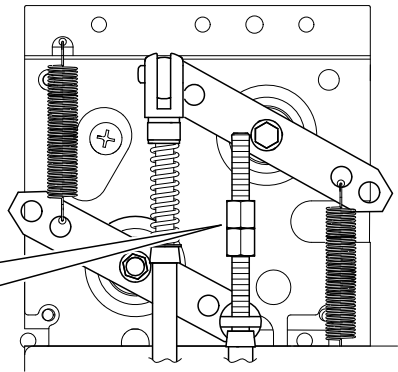

TYPE A

ACB 1	ACB 2
0	0
1	0
0	1

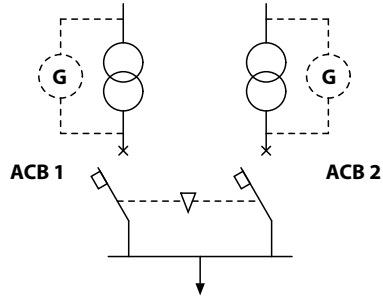

ACB 1			ACB 2			Test
	<input type="radio"/>	charged		<input type="radio"/>	charged	
①	<input type="checkbox"/>	discharged	②	<input type="radio"/>	charged	✓
①	<input type="checkbox"/>	discharged	②	<input type="checkbox"/>	discharged	✗

ACB 1			ACB 2			Test
	<input type="radio"/>	charged		<input type="radio"/>	charged	
②	<input type="radio"/>	charged	①	<input type="checkbox"/>	discharged	✓
②	<input type="checkbox"/>	discharged	①	<input type="checkbox"/>	discharged	✗

ACB 1			ACB 2			Test
	<input type="radio"/>	charged		<input type="radio"/>	charged	
①	<input type="radio"/>	charged	②	<input type="radio"/>	charged	✗
②	<input type="radio"/>	charged	①	<input type="radio"/>	charged	✗



FR BE CA LU CH

**Consignes de sécurité**

Ce produit doit être installé conformément aux règles d'installation et de préférence par un électricien qualifié. Une installation et une utilisation incorrectes peuvent entraîner des risques de choc électrique ou d'incendie. Avant d'effectuer l'installation, lire la notice, tenir compte du lieu de montage spécifique au produit. Ne pas ouvrir, démonter, altérer ou modifier l'appareil sauf mention particulière indiquée dans la notice. Tous les produits Legrand doivent exclusivement être ouverts et réparés par du personnel formé et habilité par Legrand. Toute ouverture ou réparation non autorisée annule l'intégralité des responsabilités, droits de remplacement et garanties.

Utiliser exclusivement les accessoires de la marque Legrand.



GB CA IN IE US

**Safety instructions**

This product should be installed in compliance with installation rules, preferably by a qualified electrician. Incorrect installation and use can lead to risk of electric shock or fire. Before carrying out the installation, read the instructions and take account of the product's specific mounting location. Do not open up, dismantle, alter or modify the device except where specifically required to do so by the instructions. All Legrand products must be opened and repaired exclusively by personnel trained and approved by Legrand. Any unauthorised opening or repair completely cancels all liabilities and the rights to replacement and guarantees.

Use only Legrand brand accessories.



ES CL CO CR MX PE US VE

**Consignas de seguridad**

Este producto debe instalarse conforme a las normas de instalación y preferiblemente por un electricista cualificado. Una instalación y una utilización incorrectas pueden entrañar riesgos de choque eléctrico o de incendio. Antes de efectuar la instalación, leer las instrucciones, tener en cuenta el lugar de montaje específico del producto.

No abrir, desmontar, alterar o modificar el aparato salvo que esto se indique específicamente en las instrucciones. Todos los productos Legrand deben ser abiertos y reparados exclusivamente por personal formado y habilitado por Legrand. Cualquier apertura o reparación no autorizada anula la totalidad de las responsabilidades, derechos a sustitución y garantías.

Utilizar exclusivamente los accesorios de la marca Legrand.



NL BE

**Veiligheidsvoorschriften**

Dit product moet in overeenstemming met de installatievoorschriften en bij voorkeur door een vakbekwame elektricien worden geïnstalleerd. Bij een onjuiste installatie en een onjuist gebruik bestaat het risico van elektrische schokken of brand. Lees alvorens de installatie uit te voeren de handleiding door en houd rekening met de specifieke montageplaats van het product.

U mag het apparaat niet openen, demonteren of wijzigen, tenzij dat specifiek in de handleiding wordt vermeld. Alle Legrand-producten mogen uitsluitend worden geopend en gerepareerd door personeel dat door Legrand is opgeleid en bevoegd verklaard. In geval van ongeoorloofd openen of repareren wordt geen enkele aansprakelijkheid aanvaard, vervalt het recht op vervanging en zijn de garanties niet meer geldig.

Gebruik uitsluitend accessoires van het merk Legrand.



PT

**Instruções de segurança**

Este produto deve ser instalado de acordo com as regras de instalação e de preferência por um electricista qualificado. A instalação e o uso incorrectos podem provocar riscos de choque eléctrico ou de incêndio. Antes de efectuar a instalação, ler as instruções e ter em conta a localização adequada para a montagem do produto. Não abrir, desmontar, alterar ou modificar o aparelho salvo especificação em contrário nas instruções do produto. Todos os produtos Legrand só devem ser abertos e reparados exclusivamente por pessoal formado e autorizado pela Legrand. Qualquer abertura ou reparação não autorizada cancela todas as responsabilidades, direitos de substituição e garantias. Utilizar exclusivamente os acessórios da marca Legrand.



GR CY

**Συστάσεις ασφαλείας**

Το προϊόν αυτό πρέπει να εγκατασταθεί σύμφωνα με τις οδηγίες εγκατάστασης και κατά προτίμηση από ειδικευμένο ηλεκτρολόγο. Η λανθασμένη εγκατάσταση και χρήση μπορούν να προκαλέσουν κίνδυνο ηλεκτροπληξίας ή πυρκαγιάς. Πριν πραγματοποιήσετε την εγκατάσταση, διαβάστε τις οδηγίες λαμβάνοντας υπόψη τον χώρο τοποθέτησης του προϊόντος.

Μην ανοίγετε, αποσυρμαρμολογείτε, τροποποιείτε ή επεμβαίνετε στο προϊόν εκτός κι αν υπάρχουν σαφείς σχετικές οδηγίες στο εγχειρίδιο. Όλα τα προϊόντα της Legrand πρέπει να ανοίγονται και να επισκευάζονται αποκλειστικά από εκπαιδευμένο και εξουσιοδοτημένο από τη Legrand προσωπικό. Οποιαδήποτε επέμβαση ή επιδιόρθωση πραγματοποιηθεί χωρίς άδεια, ακυρώνει το σύνολο των ευθυνών, δικαιωμάτων αντικατάστασης και εγγυήσεων.

Να χρησιμοποιείτε αποκλειστικά εξαρτήματα επωνυμίας Legrand.



RU

**Меры предосторожности**

Установка данного изделия должна выполняться в соответствии с правилами монтажа и предпочтительно квалифицированным электриком. Неправильный монтаж или нарушение правил эксплуатации изделия могут привести к возникновению пожара или поражению электрическим током. Перед монтажом необходимо внимательно ознакомиться с данной инструкцией, а также принять во внимание требования к месту установки изделия.

Запрещается вскрывать корпус изделия, а также разбирать, выводить из строя или модифицировать изделие, кроме случаев, оговоренных в инструкции. Вскрытие и ремонт изделий марки Legrand могут выполняться только специалистами, обученными и допущенными к таким работам компанией Legrand. Несанкционированное вскрытие или выполнение ремонтных работ посторонними лицами лишает законной силы любые требования об ответственности, замене или гарантийном обслуживании. При ремонте или гарантийном обслуживании использовать только запасные части марки Legrand.



PL

**Przepisy bezpieczeństwa**

Produkt ten powinien być montowany zgodnie z zasadami instalacji, najlepiej przez wykwalifikowanego elektryka. Niepoprawna instalacja lub złe użytkowanie mogą spowodować ryzyko porażenia prądem lub pożaru. Przed przystąpieniem do instalacji, zapoznać się z instrukcją i uwzględnić miejsce montażu urządzenia.

Nie otwierać, nie demontować ani nie modyfikować urządzenia, jeśli nie ma na ten temat specjalnej wzmianki w instrukcji. Wszystkie produkty Legrand mogą być otwierane i naprawiane wyłącznie przez pracowników przeszkolonych i upoważnionych przez Legrand. Każde otwarcie lub naprawa dokonane bez odpowiedniego upoważnienia zwalnia Legrand od wszelkiej odpowiedzialności, powoduje utratę prawa do wymiany produktu i wygaśnięcie gwarancji.

Używać wyłącznie oryginalnych części marki Legrand.



TR CY

**Güvenlik talimatları**

Bu ürün montaj kurallarına uygun olarak ve tercihen yetkili bir elektrikçi tarafından yerleştirilmelidir. Hatalı bir yerleştirme ve kullanım, elektrik çarpmasına veya yangına neden olabilir. Yerleştirmeden önce, talimatları okuyun ve ürüne özgü montaj yerine dikkat ediniz. Kılavuzda aksi belirtilmediği sürece cihazı açmayın, sökmeyin veya üzerinde değişiklik yapmayın.

Tüm Legrand ürünlerinin yalnız Legrand tarafından eğitilmiş ve yetkilendirilmiş personel tarafından açılması ve tamir edilmesi gerekir. İzin verilmeyen herhangi bir açılma veya tamir, tüm sorumlulukları, değiştirme haklarını ve garantileri iptal eder.

Yalnızca Legrand marka aksesuarları kullanın.

**إرشادات الأمان**

يجب تركيب هذا المنتج طبقاً لقواعد التركيب ويفضل أن يقوم بالتركيب كهربائي مؤهل. فقد يؤدي التركيب الخاطئ أو الاستخدام الخاطئ إلى مخاطر التعرض لصدمة كهربائية أو نشوب حريق. اقرأ النشرة قبل التركيب، وافرد مكاناً تركيب المنتج خاصاً به. لا تفتح أو تحل أو تحوّر المنتج ما لم يُشر إلى ذلك بشكل محدد في النشرة. فكل منتجات Legrand يجب فتحها وإصلاحها حصراً من قبل فنيين متربين ومؤهلين لدى Legrand. وكل فتح أو إصلاح غير مسموح به يبطل المسؤوليات وحقوق الاستبدال والضمانات.

لا تستخدم سوى إكسسورات من ماركة Legrand حصراً.