

Part number

CHIR 16

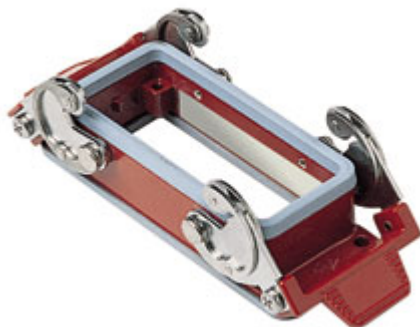

Bulkhead mounting housing, 180 °C series,
with 2 levers, size "77.27"

Product description

Product type	Bulkhead mounting housing
Series	180 °C
Closing type	With 2 levers
Size	Size "77.27"

Technical data

IP degree of protection	IP65
--------------------------------	------

Further technical details

Weight	193,00 g
Operating temperature range (min, max)	-40°C ... +180°C

Material properties

RoHs conformity	Compliant
China RoHs - EFUP	E
REACH SVHC substances	No

Approvals / Standards

Certifications	DNV-GL, BV
UL	ECBT2
cUL	ECBT8

General ordering information

EAN13 code	8015747019118
eCl@ss 8.1	27440202
ETIM 7.0	EC000437

Packaging Information

Sub-packaging weight	0,97 kg
Sub-packaging description	Plastic packaging
Sub-packaging quantity	5 Pcs
Sub-packaging EAN barcode	8015747084550

Part number

CHIR 16



Catalogue drawings

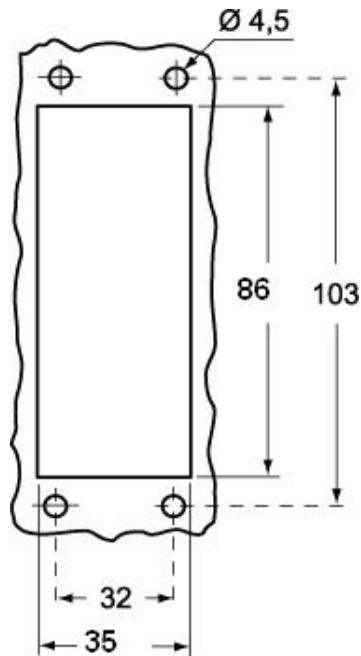

Catalogue drawings

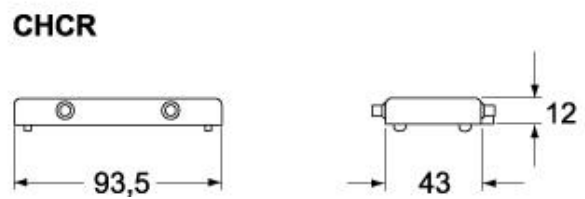
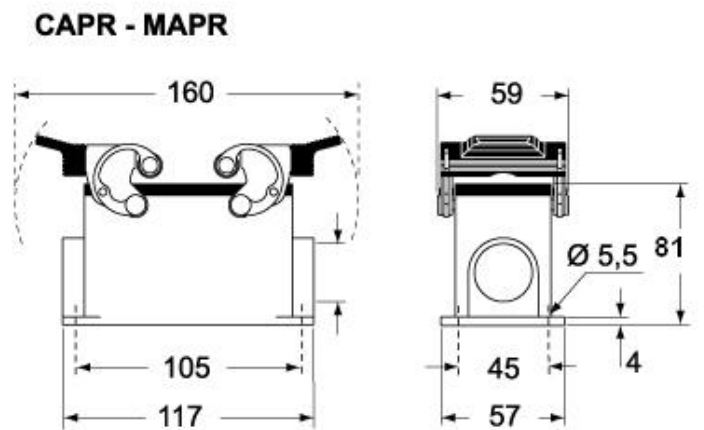
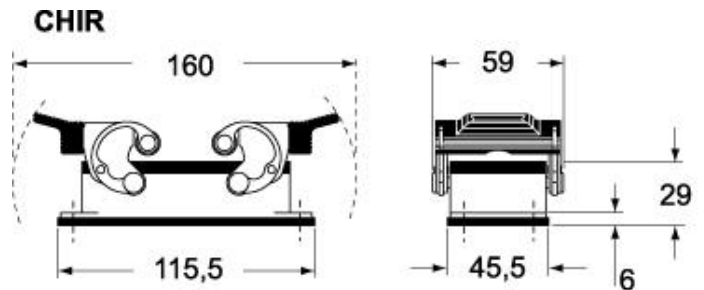

Notes

Dimensions shown in mm are not binding and may be changed without notice.

ATTENTION: PRODUCT IN MODIFICATION. FOR FURTHER INFORMATION PLEASE CONTACT OUR COMMERCIAL DEPARTMENT.